

Somfy Flush Connector Housing

PRODUCT SPECIFICATIONS

It's what you don't see that makes it special

Revolutionary pre-wiring solution designed for easy access and protection of Somfy inline connectors. For internal use only.

PRODUCT MAIN FUNCTIONALITIES



Easy to install
Compact 25 mm diameter



**Flush ceiling
or wall
mount**



**Easy access for
maintenance**



**Neatly fitted
Connectors**



Somfy Flush Connector Housing

PRODUCT SPECIFICATIONS

BENEFITS FOR PROFESSIONALS

Easy Integration

- Suitable for all Somfy motors with inline connectors
- Simple design
- For internal use only

Easy Installation

- Pre-wiring
- Easy access and maintenance
- Neatly fitted

BENEFITS FOR END USERS

Aesthetic Integration

- Nice clean finish
- No more visible cables for an elegant display
- Safe access

PRODUCT DIMENSIONS

Please ensure the drilled hole to place the flush connector housing is wide enough – we recommend a diameter of 28 mm

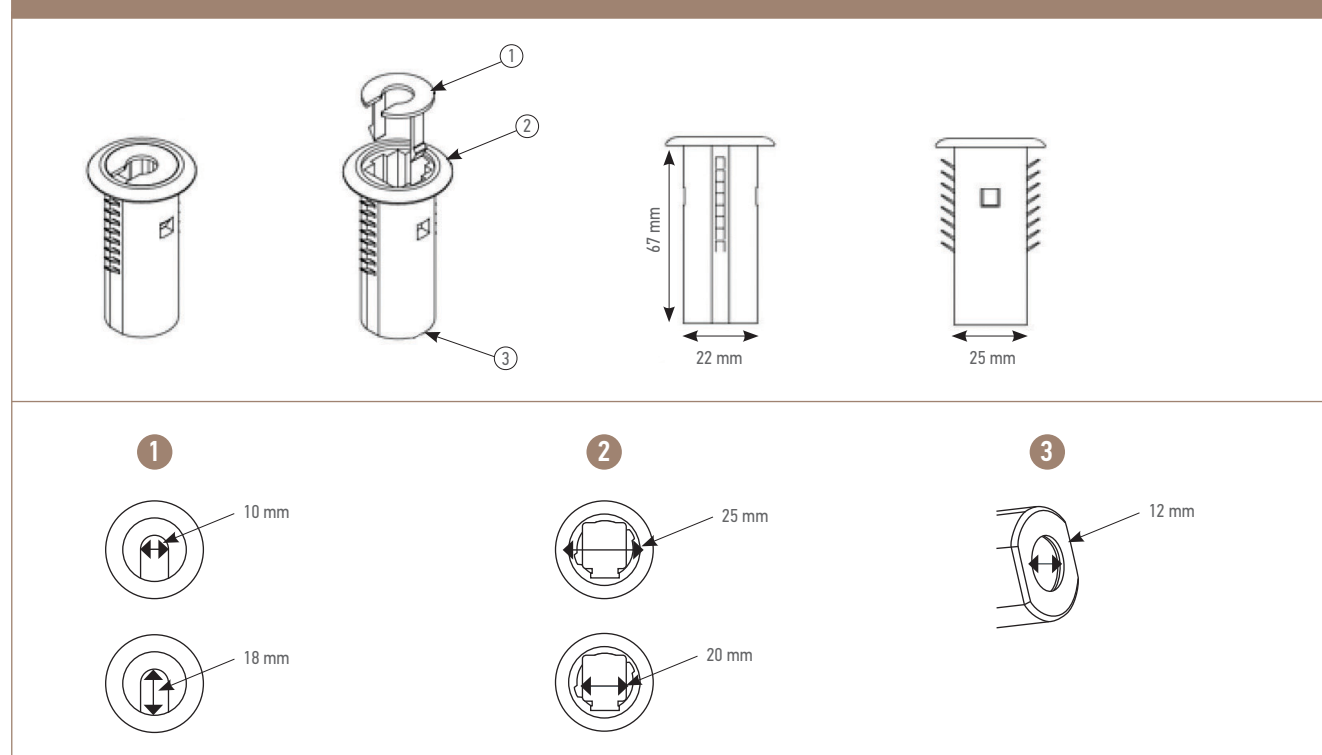

PRODUCT DISPLAY

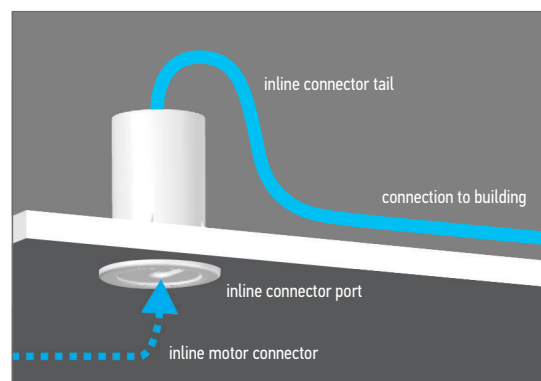

TECHNICAL DATA

Item number	9026397
Item description	Flush Connector Housing
Size	67 x 22 x 25 mm
Colour	White
Patented Design:	Au Pat 2018100721