

Operation and installation manual

KNX IP Router

Ref. 9018248B

Compact bus powered Router between LAN/Ethernet and KNX bus



KNX IP Router

Application

The KNX IP Router allows forwarding of telegrams between different lines (TP) through a LAN (IP) as a fast backbone (KNXnet/IP Routing). The KNX IP Router can also be used as an interface for accessing the bus via IP (KNXnet/IP Tunneling).

The device supports 5 simultaneous KNXnet/IP Tunneling connections.

The IP address can be obtained by a DHCP server or by manual configuration (ETS) respectively. Power is supplied via the KNX bus.

Coupler function (KNXnet/IP Routing)

The KNX IP Router operates as a line or backbone coupler. In both cases, the LAN (IP) is used as a backbone.

The following table shows the application possibilities of the KNX IP Router compared to the classic topology:

	Classical Topology (without IP)	IP coupling of areas (IP area coupl.)	IP coupling of lines (IP line coupler)
Area (Backbone)	TP	IP	IP
Coupling	KNX Line Coupler (max. 15 Pcs.)	KNX IP Router (max. 15 Pcs.)	Directly via LAN Switch
Main line	TP	TP	IP
Coupling	KNX Line Coupler (max. 15x15 Pcs.)	KNX Line Coupler (max. 15x15 Pcs.)	KNX IP Router (max. 225 Pcs..)
Line	TP	TP	TP

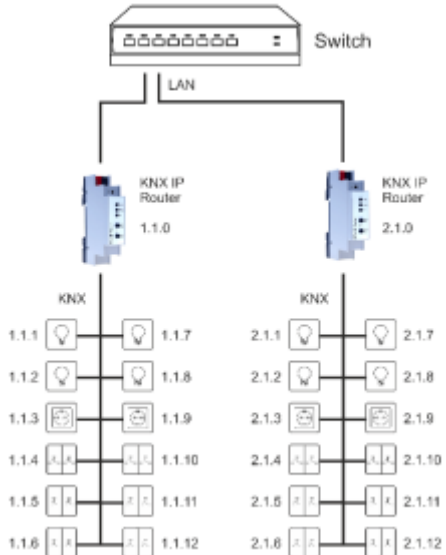

KNX IP Router as line coupler

The individual address assigned to the KNX IP Router determines whether the device operates as a line or area coupler. If the individual address is in the form of x.y.0 (x, y: 1..15), the router operates as a line coupler. If it is in the form of x.0.0 (x: 1..15), the router acts as a backbone coupler.

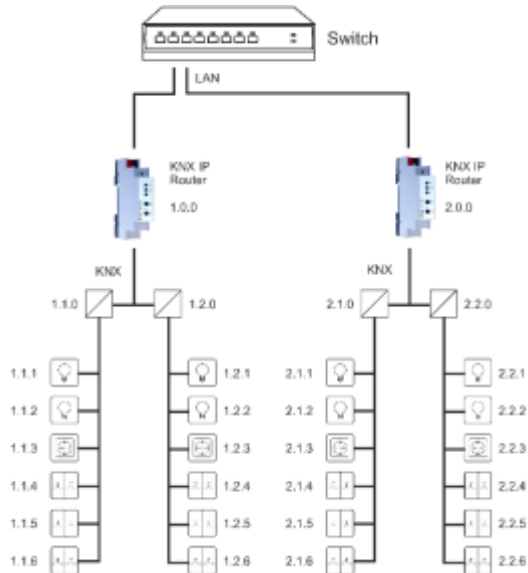

KNX IP Router as area coupler



If the KNX IP Router is used as a area coupler (x.0.0), there must not be a KNX IP Router in the topology beneath it. For example, if a KNX IP Router has the individual address 1.0.0, there must be no KNX IP Router with the address 1.1.0.



If the KNX IP Router is used as a line coupler (x.y.0), there must not be a KNX IP Router in the topology above it. For example, if a KNX IP Router has the individual address 1.1.0, there must be no KNX IP Router with the address 1.0.0.

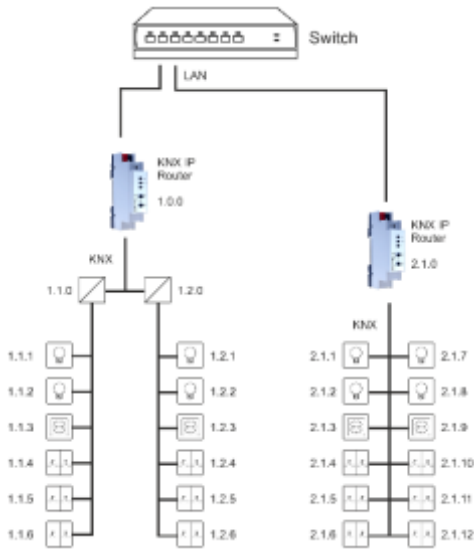

KNX IP Router as area and line coupler

The KNX IP Router has a filter table and thus contributes to reducing the bus load. The filter table (8kB) supports the extended group address range and is automatically generated by the ETS.

Because of the speed difference between the Ethernet (10 Mbit/s) and KNX TP (9.6 kbit/s), a far greater number of telegrams can be transmitted on IP. If several consecutive telegrams are transmitted for the same line, they must be buffered in the router to avoid telegram loss. The KNX IP Router has a memory for 150 telegrams (from IP to KNX).

Bus access function (KNXnet/IP Tunneling)

The KNX IP Router can be used as an interface to KNX. The KNX bus can be accessed from any point in the LAN. For this purpose, an additional individual address must be assigned. This is described in the following sections.

Installation and Connection

The KNX IP Router is designed for installation on a DIN rail with a width of 1 unit (18mm). It features the following controls and displays:

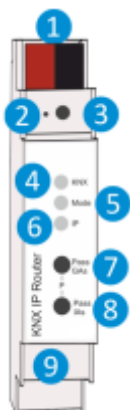

- 1 KNX bus connector
- 2 Programming LED
- 3 Button f. programming mode
- 4 KNX LED (multicolor)
- 5 Mode LED (multicolor)
- 6 IP LED (multicolor)
- 7 Button Pass GAs
- 8 Button Pass IAs
- 9 LAN Connector

The KNX IP Router is powered by the KNX bus. An external power supply is not necessary.



The device is not working without bus power.

KNX Programming mode

The KNX programming mode is activated/deactivated either by pressing the flushed KNX programming button 3 or by simultaneously pressing the buttons 7 and 8.

Status display

The KNX LED 4 lights up green if the device is successfully powered by the KNX bus. This LED indicates telegram traffic on the KNX bus by flickering.

Communication failures (e.g. repetitions of telegrams or telegram fragments) are indicated by a short change of the LED color to red.

Overview of the different indications of the KNX LED 4:

LED Status	Meaning
LED lights green	KNX bus voltage available.
LED flickers green	Telegram traffic on the KNX bus
LED shortly red	Communication failures on the KNX bus

The IP LED 6 lights up when an Ethernet link is active. This LED is green if the device has valid IP settings (IP address, Sub net and Gateway). With invalid or nonexistent IP settings the LED is red. This is also the case if e.g. the device has not yet received the IP settings by a DHCP server.

This LED indicates IP telegram traffic by flickering.

Overview of the different indications of the IP LED 6:

LED Status	Meaning
LED lights green	The device has an active Ethernet link and valid IP settings.
LED lights red	The device has an active Ethernet link and invalid IP settings or not yet received the IP settings by a DHCP server.
LED flickers green	IP telegram traffic

For testing purposes (for example, during commissioning) the configured routing settings (filter or block) can be bypassed via manual operation.

With the button Pass GAs 7 the forwarding of group addressed telegrams can be activated.

With the button Pass IAs 8 the forwarding of individually addressed telegrams can be activated.

This is visualized with a single flash of the Mode LED 5 (orange). If both modes are activated the Mode LED 5 flashes two times.

Pressing button Pass GAs 7 or button Pass IAs 8 again these settings can be selected and deselected on demand. Via the Escape function (Esc) the manual operation can be stopped by simultaneously pressing the buttons Pass GAs 7 and Pass IAs 8.

If neither programming mode nor manual mode are active the LED 5 can visualize configuration errors.

Overview of the different indications of the Mode LED:

LED Status	Meaning
LED lights green	Device is working in standard operation mode.
LED light red	Programming mode is active
LED flashes 1x orange	Programming mode is not active. Manual operation is active. Forwarding IA or GA
LED flashes 2x orange	Programming mode is not active. Manual operation is active. Forwarding IA and GA
LED flashes red	Programming mode is not active. Manual operation is not active. The device is not properly loaded e.g. after an interrupted download.

Factory default settings

The following configuration is set by factory default:

Individual device address: **15.15.0**
 Number of configured KNXnet/IP tunneling con.: **1**
 Individual address of tunneling con.: **15.15.250**
 IP address assignment: **DHCP**

Reset to factory device settings

It is possible to reset the device to its factory settings:

- Disconnect the KNX Bus connector **1** from device
- Press the KNX programming button **3** and keep it pressed down
- Reconnect the KNX Bus connector **1** of device
- Keep the KNX programming button **3** pressed for at least another 6 seconds
- A short flashing of all LEDs (**2 4 5 6**) visualizes the successful reset of the device to factory default settings.

Interface settings with ETS

Within the ETS KNX interfaces can be selected and set up via the ETS menu "Bus Interfaces".

The ETS can access configured KNX IP Routers even without a database entry. If the setup of the KNX IP Router does not comply with the conditions of the KNX installation it must be configured via an ETS project. See the ETS database section for more information.

As factory default the assignment of the IP address is set to "automatically via DHCP" and thus no further settings are necessary. To use this feature a DHCP server on the LAN must exist (e.g. many DSL routers have an integrated DHCP server).

After connecting the KNX IP Router to the LAN and the KNX bus, it should automatically appear in the ETS within the menu "Bus" under "Discovered interfaces".

By clicking on the discovered interface it is selected as the current interface. On the right side of the ETS window all specific information and options of the connection appear.

The indicated device name and the "Host Individual Address" (individual address of the device) can be changed within your ETS project then.

Like all programmable KNX devices the KNX IP Router has an individual address which can be used to access the device. This is used, for example, of the ETS when downloading to the KNX IP Router via the bus.

For the interface function the device contains additional individual addresses that can be set in the ETS (ETS 4.2 or higher). When a client (e.g. ETS) sends via the KNX IP Router

telegrams to the bus, they contain a sender address as one from the additional addresses. Each address is associated with a connection. Thus response telegrams can be clearly transmitted to the respective client.

The additional individual addresses must be selected from the address range of the bus line in which the interface is installed and may not be used by another device.

Example:

Device address	1.1.0	(address within ETS topology)
Connection 1	1.1.250	(1. additional address)
Connection 2	1.1.251	(2. additional address)
Connection 3	1.1.252	(3. additional address)
Connection 4	1.1.253	(4. additional address)
Connection 5	1.1.254	(5. additional address)

The section "Individual Address" enables you to change the individual KNX address of the currently used KNXnet/IP Tunneling connection. To check if the address you want to assign is unique within your KNX installation you can click the button "Address free?"

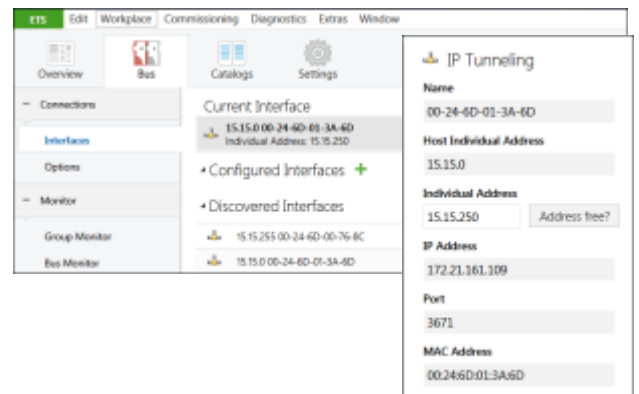

The individual KNX device address and the individual KNX addresses for additional tunneling connections can be changed within the ETS project, after the device has been added to the project.

ETS database

The ETS database (for ETS 4.2 and ETS 5) can be downloaded from the product website of the KNX IP Router (www.somfy.com/projects) For existing installations a database for ETS 3 is also available.

When using the ETS® product database for ETS 4 / 5 some settings are displayed in addition to the parameter dialog of the Properties dialog (on the right side of the ETS window). So the IP settings can be done here. In the ETS 4 also the additional individual addresses will appear. In the ETS 5 those addresses appear in the topology view.

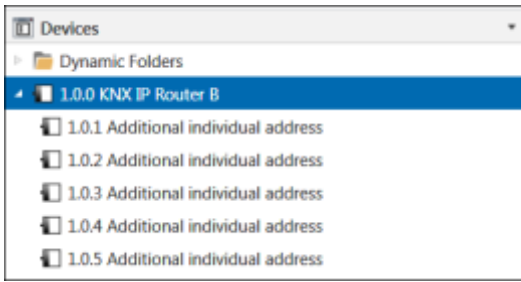

Each individual KNX address can be changed by clicking on the list entry and typing in the desired address into the "Individual Address" text-field. If the text-field frame switches to color red after entering the address, the address is already taken within your ETS project.

i Make sure that none of the addresses above are already present in your KNX installation.

i If the physical KNX addresses of the tunneling connections have been assigned via the ETS project, a manual address setting on the device is not allowed.

By clicking on the KNX IP Router device entry within your ETS projects topology view, an information column 'Properties' will appear on the right side of the ETS window. Within the 'Settings' overview, you can change the name of the device.

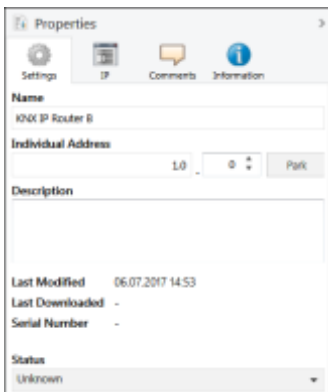

Within the "IP" overview the IP network specific options of the KNX IP Router can be changed.

By changing "obtain an IP address automatically (via DHCP)" to "Use a static IP address" (static IP address) the IP address, subnet mask, and default gateway can be set freely.

i All changes in the properties menu become effective only after a successful application download.

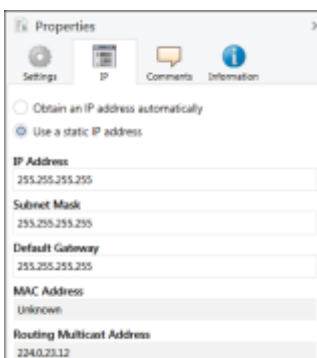

IP address

Here the IP address of the KNX IP Router can be entered. This is used to address the device via the IP network (LAN). The IP addressing should be coordinated with the administrator of the network.

Subnet mask

Enter the subnet mask here. The device uses the values entered in this mask to determine whether there is a communication partner in the local network. If there is no partner in the local network, the device will not send the telegrams directly to the partner but to the gateway that routes the telegram.

Default gateway

Enter the IP address of the gateway here, e.g. the DSL router of the installation.

Routing Multicast Address

This address is used for routing telegrams on IP. The multicast IP address 224.0.23.12 was reserved (KNXnet/IP) at the IANA (Internet Assigned Numbers Authority) for this purpose. If a different multicast IP address is required, it must be within the range of 239.0.0.0 to 239.255.255.255.

Example of assigning IP addresses

A PC is to be used to access the KNX IP Router.

IP address of the PC: 192.168.1.30

Subnet of the PC: 255.255.255.0

The KNX IP Router is located in the same LAN, i.e. it uses the same subnet. The subnet constrains the IP addresses that can be assigned. In this example, the IP address of the KNX IP Router must be 192.168.1.xx, where xx can be a number from 1 to 254 (with the exception of 30, which is already taken by the client PC). It must be ensured that no IP addresses are assigned twice.

IP address of the KNX IP Router 192.168.1.31

Subnet of the KNX IP Router: 255.255.255.0

ETS parameter dialogue

The following parameters can be set using the ETS.

General settings



Prog. mode on device front

In addition to the normal programming button **3** the device allows activating the programming mode on the device front without opening the switchboard cover. The programming mode can be activated and deactivated via pressing simultaneously both buttons **7** and **8**.

This feature can be enabled and disabled via the parameter "Prog. mode on device front". The recessed programming button **3** (next to the Programming LED **2**) is always enabled and not influenced by this parameter.

Manual operation on device

This parameter sets the duration of the manual mode. Upon completion the normal display mode is restored.

Routing (KNX -> IP)

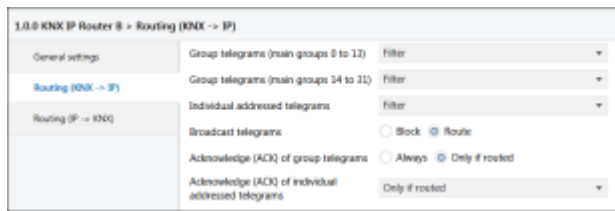

Group telegrams (main group 0 to 13)

Block: No group telegrams of this main group are routed to IP.

Route: All group telegrams of this main group are routed to IP independent of the filter table. This setting is for test purposes only.

Filter: The filter table is used to check whether or not the received group telegram should be routed to IP.

Group telegrams (main group 14 to 31)

Block: No group telegrams of main groups 14 to 31 are routed to IP.

Route: All group telegrams of main groups 14 to 31 are routed to IP.

Filter: The filter table is used to check whether or not the received group telegram should be routed to IP.

Individually addressed telegrams

Block: No individually addressed telegrams are routed to IP.

Route: All individually addressed telegrams are routed to IP.

Filter: The individual address is used to check whether the received individually addressed telegram should be routed to IP.

Broadcast telegrams

Block: No received broadcast telegrams are routed to IP.

Route: All received broadcast telegrams are routed to IP.

Acknowledge (ACK) of group telegrams

Always: A acknowledge is generated for every received group telegram (from KNX).

Only if routed: A acknowledge is only generated for received group telegrams (from KNX) if they are routed to IP.

Acknowledge (ACK) of individually addressed telegrams

Always: A acknowledge is generated for every received individual addressed telegram (from KNX).

Only if routed: A acknowledge is only generated for received individually addressed group

telegrams (from KNX) if they are routed to IP.

Answer with NACK: Every received individually addressed telegram (from KNX) is responded to with NACK (Not acknowledge). This means that communication with individually addressed telegrams on the corresponding KNX line is not possible. Group communication (group telegrams) is not affected. This setting can be used to block attempts at manipulation.



When using "Answer with NACK" an access to the device via KNX TP is no longer possible. The configuration must be performed via IP.

Routing (IP -> KNX)

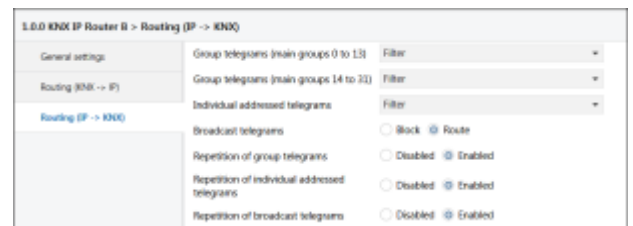

Group telegrams (main group 0 to 13)

Block: No group telegrams of these main groups are routed to KNX.

Route: All group telegrams of this main group are routed to KNXG independent of the filter table. This setting is used for testing purposes only.

Filter: The filter table is used to check whether the received group telegram should be routed to KNX.

Group telegrams (main group 14 to 31)

Block: No group telegrams of main groups 14 to 31 are routed to KNX.

Route: All group telegrams of the main groups 14 to 31 are routed to KNX.

Filter: The filter table is used to check whether the received group telegram should be routed to KNX.

Individually addressed telegrams

Block: No individually addressed telegrams are routed to KNX.

Route: All individually addressed telegrams are routed to KNX.

Filter: The individual address is used to check whether the received individually addressed telegram should be routed to KNX.

Broadcast telegrams

Block: No received broadcast telegrams are routed to KNX.

Route: All received broadcast telegrams are routed to KNX.

Repetition of group telegrams

Disabled: The received group telegram is not resent to KNX in case of a fault.

Enabled: The received group telegram is resent up to three times in case of a fault.

Repetition of individually addressed telegrams

Disabled: The received individually addressed telegram is not resent to KNX in case of a fault.

Enabled: The received individually addressed telegram is resent up to three times in case of a fault.

Repetition of broadcast telegrams

Disabled: The received broadcast telegram is not resent to KNX in case of a fault.

Enabled: The received broadcast telegram is resent up to three times in case of a fault.

Programming

The KNX IP Router can be programmed in different ways by the ETS:

Via KNX Bus

The device only needs to be connected to the KNX bus. The ETS requires an additional interface (for example, USB) to have access to the bus. Via this way both the individual address and the entire application including IP configuration can be programmed. Programming via the bus is recommended if no IP connection can be established.

Via KNXnet/IP Tunneling

No additional interface is required. Programming via KNXnet/IP Tunneling is possible if the device already has a valid IP configuration (e.g. via DHCP). In this case the device is displayed in the interface configuration of the ETS and must be selected. The download is executed via the ETS project as with many other devices.

Via KNXnet/IP Routing

Programming via KNXnet/IP Routing is possible if the device already has a valid IP configuration (e.g. by using DHCP or Auto IP). In the ETS, the routing interface appears if at least one device on the network which supports routing is available. The name of the network interface appears in the PC as description. If routing is selected as interface, the programming done from the ETS project as like with other devices. In this case LAN is used as a KNX medium like TP. There is no additional interface device required.

Via direct IP connection

While KNXnet/IP Tunneling and KNXnet/IP Routing is limited to the speed of KNX TP the device can be loaded via a direct IP connection at high speed. The direct IP connection is possible if the device already has a valid IP configuration as well as an

individual address. To do this select "Use direct IP connection if available" in the ETS menu "Bus – Connections - Options". The download is then directly performed in the device and is not visible in the ETS group monitor.

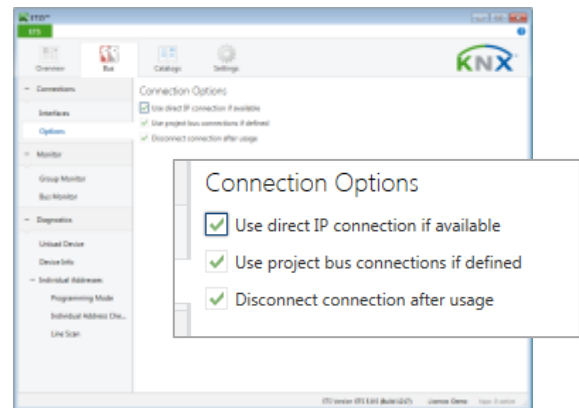

i Due to the significantly shorter transmission times it is recommended to perform downloads via IP.

Setting with ETS 3

When using the ETS 3 (Version 3.0f) the setting of the device's name and the setting of the IP configuration is done via the ETS parameter dialogue.

The KNX IP Router can be selected in the Connection Manager as a programming interface. Select "Communication" within the menu item "Tools - Options":

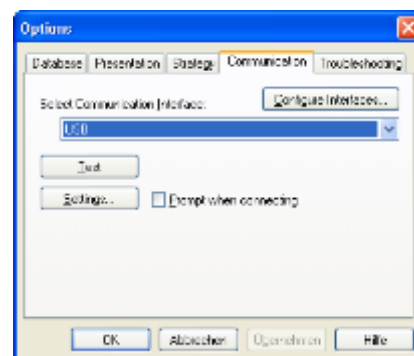

After clicking the button "Configure Interfaces" the ETS Connection Manager opens. You have to create a new connection type EIBnet/IP. The ETS begins with the automatic search of all KNXnet/IP devices. All found devices are displayed. Select the required device.

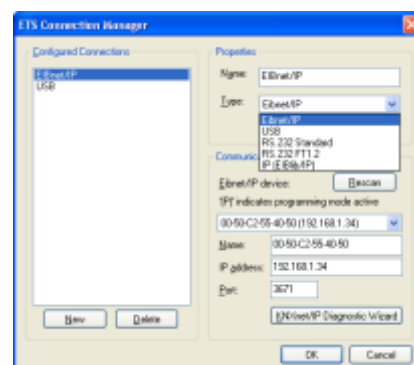

The KNX IP Router supports up to 5 simultaneous connections. For each connection a separate individual address is used.

The first additional individual address is assigned by the ETS. By clicking on the 'Settings' at the selected connection "Local Settings" this dialogue box with a corresponding input field appears:

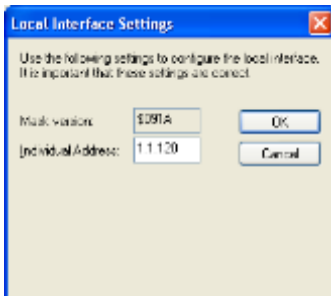

The further additional addresses can be assigned directly on the device. This is done by pressing the programming button ③ at least one second. Then, the programming LED flashes ② and the addresses are assigned as follows:

Connection 2 gets the next higher address than connection 1, connection 3 gets the next higher address than connection 2, etc.

Example

Device address	1.1.0	(address within ETS topology)
Connection 1	1.1.250	(address within local settings)
Connection 2	1.1.251	(assigned by programming button)
Connection 3	1.1.252	(assigned by programming button)
Connection 4	1.1.253	(assigned by programming button)
Connection 5	1.1.254	(assigned by programming button)

The additional individual addresses have to be valid within the sub line of the KNX IP Router and not be used by another device. By factory default only the additional individual address of the first connection is active (which is preassigned to 15.15.250). To use more connections simultaneously, additional address assignment must be performed as described above.



SOMFY ACTIVITES SA
50 Avenue du Nouveau Monde
74300 Cluses
France
T +33 (0)4 50 96 70 00
F + 33 (0)4 50 96 71 89
www.somfy.com/projects

Société Anonyme
Capital: 35.000.000 €
RCS ANNECY 303.970.230



WARNING

- The device may be built into distribution boards (230/400V).
- The device must be mounted and commissioned by an authorized electrician.
- The prevailing safety rules must be heeded.
- The device must not be opened.
- For planning and construction of electric installations, the relevant guidelines, regulations and standards of the respective country are to be considered.