

SGS LINE

- FR Manuel d'installation et d'utilisation
- EN Operating and installation guide
- DE Montage- und Gebrauchsanleitung
- NL Gids voor de installatie en het gebruik
- RO Manual de instalare și utilizare



5149567A



Sommaire

Consignes de sécurité	2	3 Câblage des accessoires	22
- Informations importantes	2	3.1 Cellules photoélectriques	22
- Etat du portail à motoriser	2	3.2 Feu clignotant	22
- Installation électrique	2	3.3 Batterie (option)	22
- Passage des câbles	3	3.4 Antenne déportée (option)	23
- Consignes de sécurités relatives à l'installation de la motorisation	3	3.5 Visiophone (option)	23
- Consignes de sécurité relatives à l'utilisation	3	3.6 Contact à clé (option)	23
- Consignes de sécurité relatives à la maintenance	4	3.7 Eclairage de zone (option)	23
- A propos des piles	4	3.8 Alimentation solaire (option)	23
- Recyclage et mise au rebut	4	4 Paramétrages avancés	24
- Réglementation	4	4.1 Ouverture piétonne	24
- Prévention des risques	4	- Fonctionnement de l'ouverture piétonne	24
Présentation du produit	6	- Activer l'ouverture piétonne	24
- Contenu du pack	6	- Désactiver l'ouverture piétonne	24
- Description du produit	7	4.2 Fermeture automatique	25
- Encombrement	7	- Fonctionnement de la fermeture automatique	25
- Domaine d'application	7	- Activer la fermeture automatique	25
- Vue générale de l'installation	8	- Désactiver la fermeture automatique	26
- Présentation de l'électronique de commande	9	5 Programmation des télécommandes	27
Pré-requis pour l'installation	9	5.1 Présentation des télécommandes	27
- Points à vérifier avant l'installation	9	- Possibilités de programmation de la télécommande	
- Pré-équipement électrique	10	2 touches	27
- Câbles à prévoir	10	- Possibilités de programmation de la télécommande	
- Outillage nécessaire à l'installation (non fourni)	11	4 touches	27
- Visserie nécessaire à l'installation (non fournie)	11	- Utilisation d'une télécommande 3 touches	27
1 Installation	12	5.2 Ajouter une télécommande	28
1.1 Relever les cotes	12	- Télécommande 2 ou 4 touches	28
1.2 Fixation des pattes pilier	13	- Télécommande 3 touches	28
- Tracer les axes AM et AH	13	5.3 Supprimer les télécommandes	28
- Percer les piliers	13	6 Aide au dépannage	29
- Fixer la patte de fixation pilier	14	6.1 Assistance	29
- Monter le vérin sur la patte de fixation	14	6.2 Changer la pile de la télécommande	29
1.3 Fixation des moteurs aux vantaux	14	6.3 Effacer les réglages	30
1.4 Installation du boîtier de commande	16	6.4 Déverrouiller / verrouiller les moteurs	30
- Position du boîtier de commande	16	6.5 Diagnostic	31
- Installer le cordon d'étanchéité	16	7 Caractéristiques techniques	32
- Vérifier la position de l'antenne	16		
- Fixer le boîtier de commande	16		
1.5 Raccordement des moteurs	18		
1.6 Raccordement à l'alimentation secteur	18		
2 Mise en service et utilisation standard	19		
2.1 Mettre l'installation sous tension	19		
2.2 Réglage de la butée d'ouverture	19		
2.3 Auto-apprentissage de la course du portail	20		
2.4 Fermer le boîtier de commande	21		
2.5 Mise en veille/Réveil de l'électronique de commande	21		
2.6 Ouverture totale et fermeture du portail	21		
2.7 Détection d' obstacle	21		
2.8 Formation des utilisateurs	21		

► Consignes de sécurité

 Ce symbole signale un danger dont les différents degrés sont décrits ci-dessous.

DANGER

Signale un danger entraînant immédiatement la mort ou des blessures graves.

AVERTISSEMENT

Signale un danger susceptible d'entraîner la mort ou des blessures graves.

PRÉCAUTION

Signale un danger susceptible d'entraîner des blessures légères ou moyennement graves.

ATTENTION

Signale un danger susceptible d'endommager ou de détruire le produit.

AVERTISSEMENT

MISE EN GARDE - Instructions importantes de sécurité.

Il est important pour la sécurité des personnes de suivre toutes les instructions car une installation incorrecte peut entraîner des blessures graves. Conserver ces instructions. L'installateur doit impérativement former tous les utilisateurs pour garantir une utilisation en toute sécurité de la motorisation conformément au manuel d'utilisation. Les instructions doivent être remises à l'utilisateur final.

► Informations importantes

Ce produit est une motorisation pour un portail battant en usage résidentiel tel que défini dans la norme EN 60335-2-103, à laquelle il est conforme. Ces instructions ont notamment pour objectif de satisfaire les exigences des dites normes et ainsi d'assurer la sécurité des biens et des personnes.

AVERTISSEMENT

Toute utilisation de ce produit hors du domaine d'application décrit dans ce manuel est interdite (voir paragraphe «Domaine d'application» du manuel). L'utilisation de tout accessoire ou de tout composant non préconisé par Somfy est interdite - la sécurité des personnes ne serait pas assurée. Somfy ne peut pas être tenu pour responsable des dommages résultant du non respect des instructions de ce manuel.

Si un doute apparaît lors de l'installation de la motorisation ou pour obtenir des informations complémentaires, consulter le site internet www.somfy.com. Ces instructions sont susceptibles d'être modifiées en cas d'évolution des normes ou de la motorisation.

► Etat du portail à motoriser

Avant d'installer la motorisation, vérifier que :

- le portail est en bonne condition mécanique.
- le portail est stable quelque soit sa position.
- les structures supportant le portail permettent de fixer la motorisation solidement. Les renforcer si nécessaire.
- le portail se ferme et s'ouvre manuellement convenablement avec une force inférieure à 150 N.
- la plage de température marquée sur la motorisation est adaptée à l'emplacement.

ATTENTION

Ne pas projeter d'eau sur la motorisation.
Ne pas installer la motorisation dans un milieu explosif.

AVERTISSEMENT

S'assurer que les zones dangereuses (écrasement, cisaillement, coincement) entre la partie entraînée et les parties fixes environnantes dues au mouvement d'ouverture de la partie entraînée sont évitées ou signalées sur l'installation (voir «Prévention des risques»).

Fixer à demeure les étiquettes de mise en garde contre l'écrasement à un endroit très visible ou près des dispositifs de commande fixes éventuels.

► Installation électrique

DANGER

L'installation de l'alimentation électrique doit être conforme aux normes en vigueur dans le pays où est installée la motorisation et doit être faite par un personnel qualifié.

DANGER

La ligne électrique doit être exclusivement réservée à la motorisation et dotée d'une protection constituée :

- d'un fusible ou disjoncteur calibre 10 A,
- et d'un dispositif de type différentiel (30 mA).

Un moyen de déconnexion omnipolaire de l'alimentation doit être prévu. Les interrupteurs prévus pour assurer une coupure omnipolaire des appareils fixes doivent être raccordés directement aux bornes d'alimentation et doivent avoir une distance de séparation des contacts sur tous les pôles pour assurer une déconnexion complète dans les conditions de catégorie de surtension III. Les câbles basse tension soumis aux intempéries doivent être au minimum de type H07RN-F. L'installation d'un parafoudre est conseillée (de tension résiduelle d'un maximum de 2 kV obligatoire).

► Passage des câbles

DANGER

Les câbles enterrés doivent être équipés d'une gaine de protection de diamètre suffisant pour passer le câble du moteur et les câbles des accessoires. Pour les câbles non enterrés, utiliser un passe-câble qui supportera le passage des véhicules (réf. 2400484).

► Consignes de sécurités relatives à l'installation de la motorisation

AVERTISSEMENT

Enlever tous bijoux (bracelet, chaîne ou autres) lors de l'installation. Pour les opérations de manipulation, de perçage et de soudure, porter les protections adéquates (lunettes spéciales, gants, casque antibruit, etc.).

DANGER

Ne pas raccorder la motorisation à une source d'alimentation (secteur, batterie ou solaire) avant d'avoir terminé l'installation.

AVERTISSEMENT

Il est strictement interdit de modifier l'un des éléments fournis dans ce kit ou d'utiliser un élément additif non préconisé dans ce manuel.

Surveiller le portail en mouvement et maintenir les personnes éloignées jusqu'à ce que l'installation soit terminée.

Ne pas utiliser d'adhésifs pour fixer la motorisation.

AVERTISSEMENT

Le déverrouillage manuel peut entraîner un mouvement incontrôlé du portail. Fixer à demeure l'étiquette concernant le dispositif de déverrouillage manuel près de son organe de manoeuvre.

AVERTISSEMENT

Installer tout dispositif de commande fixe à une hauteur d'au moins 1,5 m et en vue du portail mais éloigné des parties mobiles.

Après installation, s'assurer que :

- le mécanisme est correctement réglé.
- le dispositif de déverrouillage manuel fonctionne correctement.
- la motorisation change de sens quand le portail rencontre un objet de 50 mm positionné à mi-hauteur du vantail.

AVERTISSEMENT

Dans le cas d'un fonctionnement en mode automatique ou d'une commande hors vue, il est impératif d'installer des cellules photoélectriques. La motorisation en mode automatique est celle qui fonctionne au moins dans une direction sans activation intentionnelle de l'utilisateur.

Dans le cas d'un fonctionnement en mode automatique ou si le portail donne sur la voie publique, l'installation d'un feu clignotant peut être exigée, conformément à la réglementation du pays dans lequel la motorisation est mise en service.

► Consignes de sécurité relatives à l'utilisation

AVERTISSEMENT

Cette motorisation peut être utilisée par des enfants âgés d'au moins 8 ans et par des personnes ayant des capacités physiques, sensorielles ou mentales réduites ou dénuées d'expérience ou de connaissance, s'ils (si elles) sont correctement surveillé(e)s ou si des instructions relatives à l'utilisation de la motorisation en toute sécurité leur ont été données et si les risques encourus ont été appréhendés. Ne pas laisser les enfants jouer avec les dispositifs de commande du portail. Mettre les télécommandes hors de portée des enfants. Le nettoyage et l'entretien par l'utilisateur ne doivent pas être effectués par des enfants.

Le niveau de pression acoustique de la motorisation est inférieur ou égal à 70 dB(A). Le bruit émis par la structure à laquelle la motorisation sera connectée n'est pas pris en considération.

AVERTISSEMENT

Tout utilisateur potentiel doit être formé à l'utilisation de la motorisation par l'installateur appliquant toutes les préconisations de ce manuel. Il est impératif de s'assurer qu'aucune personne non formée ne puisse mettre le portail en mouvement. L'utilisateur doit surveiller le portail pendant tout les mouvements et maintenir les personnes éloignées jusqu'à ce que le portail soit complètement ouvert ou fermé. Ne pas empêcher volontairement le mouvement du portail.

AVERTISSEMENT

En cas de mauvais fonctionnement, couper l'alimentation et déverrouiller immédiatement la motorisation, afin de permettre l'accès et contacter l'assistance Somfy.

Ne pas essayer d'ouvrir manuellement le portail si la motorisation n'a pas été déverrouillée. Éviter que tout obstacle naturel (branche, pierre, herbes hautes...) puisse entraver le mouvement du portail.

► Consignes de sécurité relatives à la maintenance

⚠ DANGER

La motorisation doit être déconnectée de toute source d'alimentation durant le nettoyage, la maintenance et lors du remplacement des pièces.

⚠ AVERTISSEMENT

Vérifier chaque mois :

- l'installation pour déceler tout signe d'usure ou de détérioration des câbles et du montage.
- que la motorisation change de sens quand le portail rencontre un objet de 50 mm positionné à mi-hauteur du vantail

Ne pas utiliser la motorisation si une réparation ou un réglage est nécessaire. Les portails en mauvais état doivent être réparés, renforcés, voire changés. Utiliser exclusivement des pièces d'origine pour tout entretien ou réparation.

Toute modification technique, électronique ou mécanique sur la motorisation devra être faite avec l'accord de l'assistance Somfy.

Si l'installation est équipée de cellules photoélectriques et/ou d'un feu clignotant, nettoyer régulièrement les optiques des cellules photoélectriques et le feu clignotant.

► A propos des piles

⚠ DANGER

Ne pas laisser les piles/piles boutons/accus à la portée des enfants. Les conserver dans un endroit qui leur est inaccessible. Il y a un risque qu'elles soient avalées par des enfants ou des animaux domestiques. Danger de mort ! Si cela devait arriver malgré tout, consulter immédiatement un médecin ou se rendre à l'hôpital.

Faire attention de ne pas court-circuiter les piles, ni les jeter dans le feu, ni les recharger. Il y a un risque d'explosion.

► Recyclage et mise au rebut

La batterie, si installée, doit être retirée de la motorisation avant que celle-ci ne soit mise au rebut.

 Ne pas jeter les piles usagées des télécommandes ou la batterie, si installée, avec les déchets ménagers. Les déposer à un point de collecte dédié pour leur recyclage.

 Ne pas jeter la motorisation hors d'usage avec les déchets ménagers. Faire reprendre la motorisation par son distributeur ou utiliser les moyens de collecte sélective mis à disposition par la commune.

► Réglementation

CE Somfy déclare que le produit décrit dans ces instructions lorsqu'il est utilisé conformément à ces instructions, est conforme aux exigences essentielles des Directives Européennes applicables et en particulier à la Directive Machine 2006/42/EC et à la Directive Radio 2014/53/EU.

Le texte complet de la déclaration CE de conformité est disponible à l'adresse internet suivante : www.somfy.com/ce. Antoine CREZE, Responsable réglementation, Cluses

► Prévention des risques

Identification des zones à risque

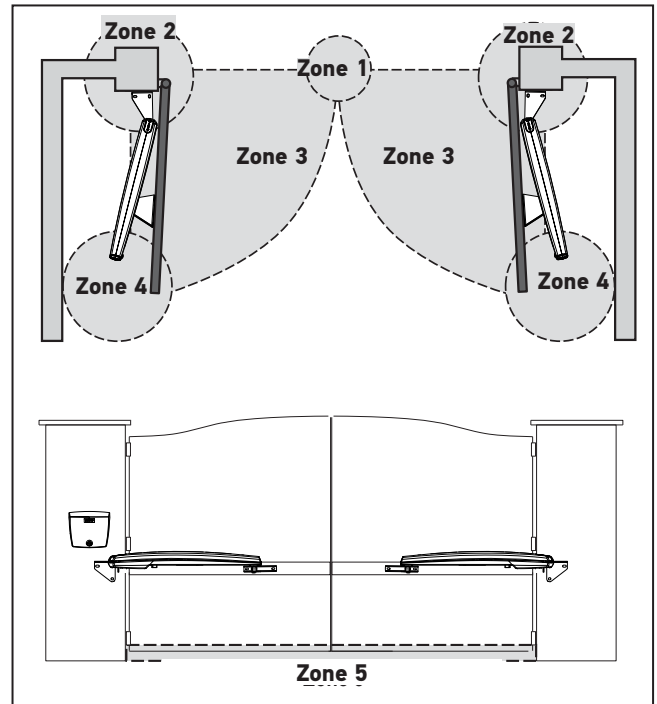

Mesures à prendre pour lever les risques

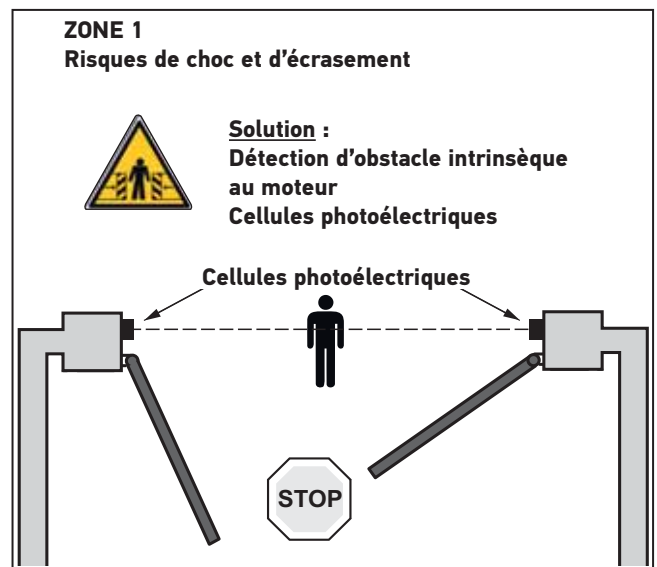

ZONE 2

Risques d'écrasement et de cisaillement des mains

**Solution :**

Si une zone de cisaillement existe sur l'installation :

- laisser une distance de 10 cm minimum entre le vantail et le pilier/mur.
- entailler le coin du pilier sans le fragiliser.

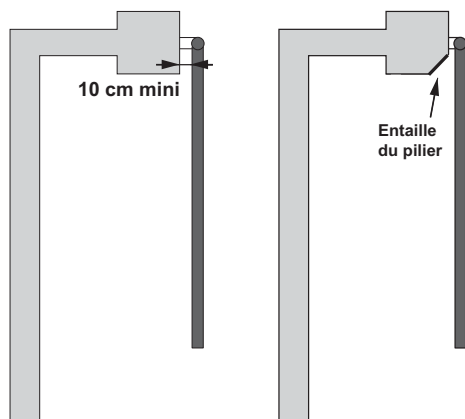
**ZONE 3**

Risque de choc

Solution :

Détection d'obstacle intrinsèque au moteur.

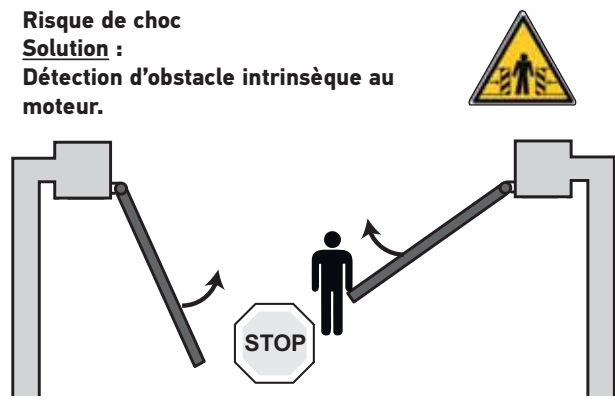
**ZONE 4**

Risque d'emprisonnement et d'écrasement

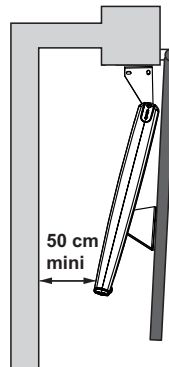
**Solution :**

Détection d'obstacle intrinsèque au moteur.

Si une zone d'emprisonnement existe entre les vantaux et les parties fixes environnantes, laisser une distance de 50 cm minimum entre les vantaux et les parties fixes.

ZONE 5

Risque d'entraînement des pieds

**Solution :**

Si une zone dangereuse pour les pieds existe entre le bas des vantaux et le sol, laisser une distance de 12 cm minimum ou 5 mm maximum entre le bas des vantaux et le sol.

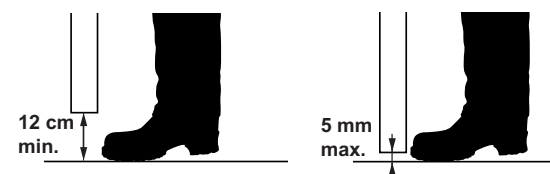

Présentation du produit

Contenu du pack

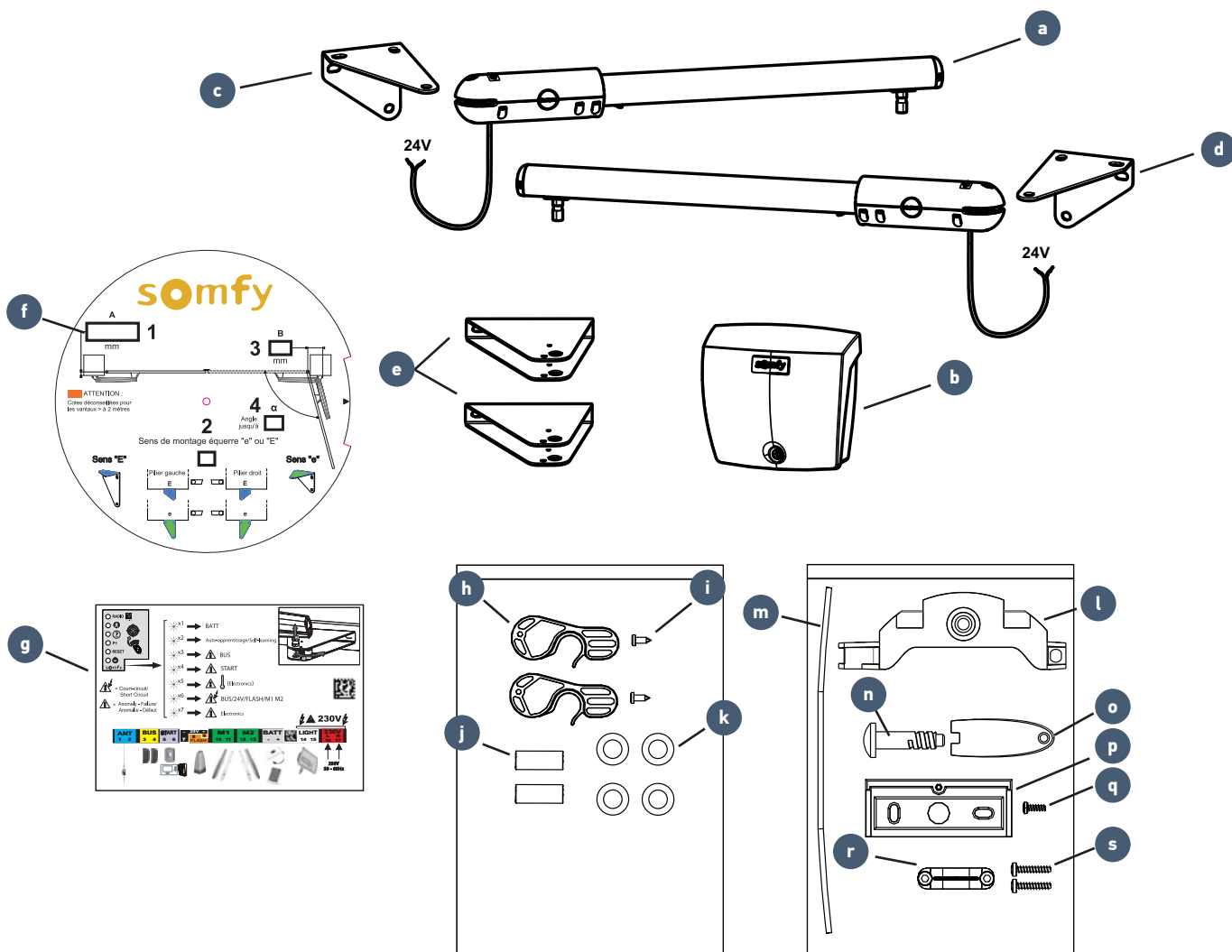

Rep.	Désignation	Quantité
a	Vérin 24V	x2
b	Boîtier de commande	x1
c	Patte de fixation gauche pilier/mur	x1
d	Patte de fixation droite pilier/mur	x1
e	Patte de fixation vantail	x2
f	Disque pour relevé de cotes	x1
g	Etiquette memo	x1
Sachet accessoires vérin		
h	Pièce de déverrouillage	x2
i	Vis pièce de déverrouillage	x2
j	Axe de fixation vérin à la patte pilier/mur	x2
k	Rondelle plate M8x22	x4

Rep.	Désignation	Quantité
Sachet accessoires boîtier de commande		
l	Support batterie	x1
m	Cordon d'étanchéité	x1
n	Vis couvercle boîtier	x1
o	Clé de déverrouillage couvercle boîtier	x1
p	Equerre de fixation au mur	x1
q	Vis de fixation du boîtier à l'équerre	x1
r	Serre-câble	x1
s	Vis serre-câble	x2

► Description du produit



► Encombrement

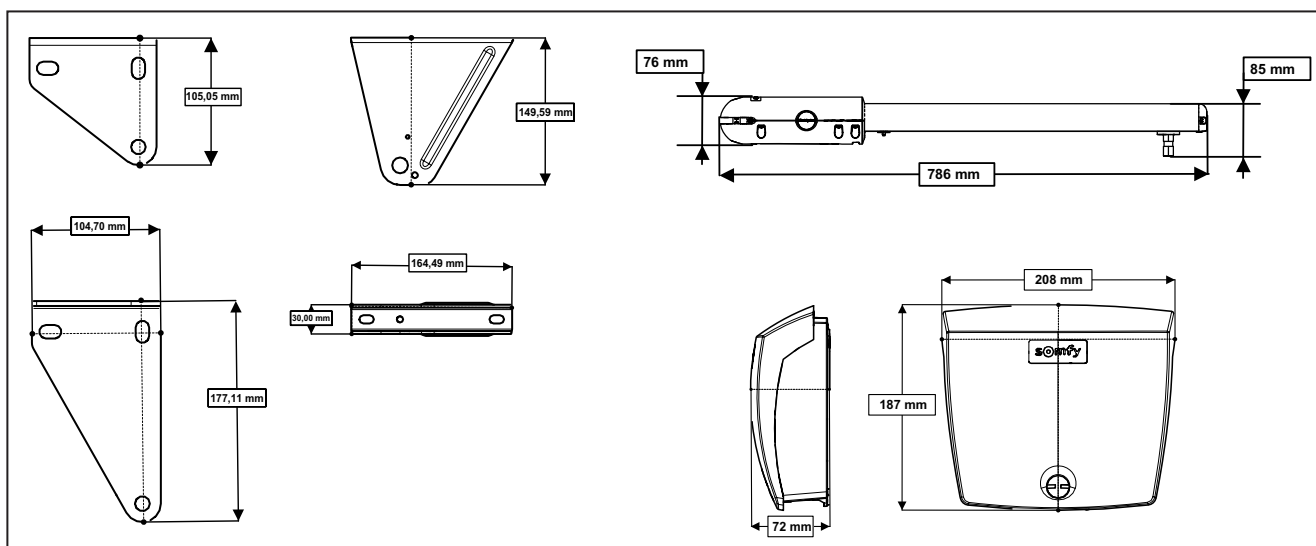

► Domaine d'application

Cet automatisme a été conçu pour motoriser des portails résidentiels à double battant pour une maison individuelle.

Dimensions et poids des vantaux

Poids max. par vantail (P)	200 kg
Hauteur max. par vantail (H)	2 m
Largeur min./max. par vantail (L)	1,25 / 2 m

Le type de portail (plein / ajouré) et les conditions climatiques (présence de vent fort), peuvent réduire ces valeurs maximums (voir tableau ci-dessous).

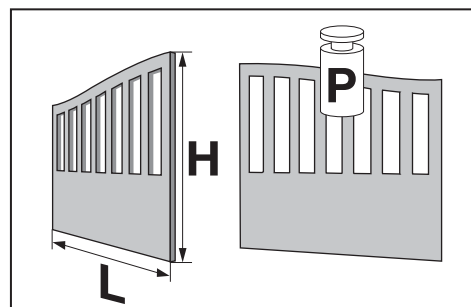

Dimensions et poids des vantaux motorisables en fonction de la force du vent

Force du vent	Effet	Produit	SGS LINE
$\geq 80 \text{ Km/h}$	On ne marche plus contre le vent		Largeur min./max. Poids max. 1,25 / 1,5 m 200 kg
$< 80 \text{ Km/h}$ $> 40 \text{ Km/h}$	Les branches des arbres s'agitent		Largeur min./max. Poids max. 1,25 / 2 m 200 kg
			Largeur min./max. Poids max. 1,25 / 1,5 m 200 kg
$\leq 40 \text{ Km/h}$	Le sable s'envole		Largeur min./max. Poids max. 1,25 / 2 m 200 kg
			
			



Portail ajouré



Portail semi-ajouré



Portail plein

► Vue générale de l'installation

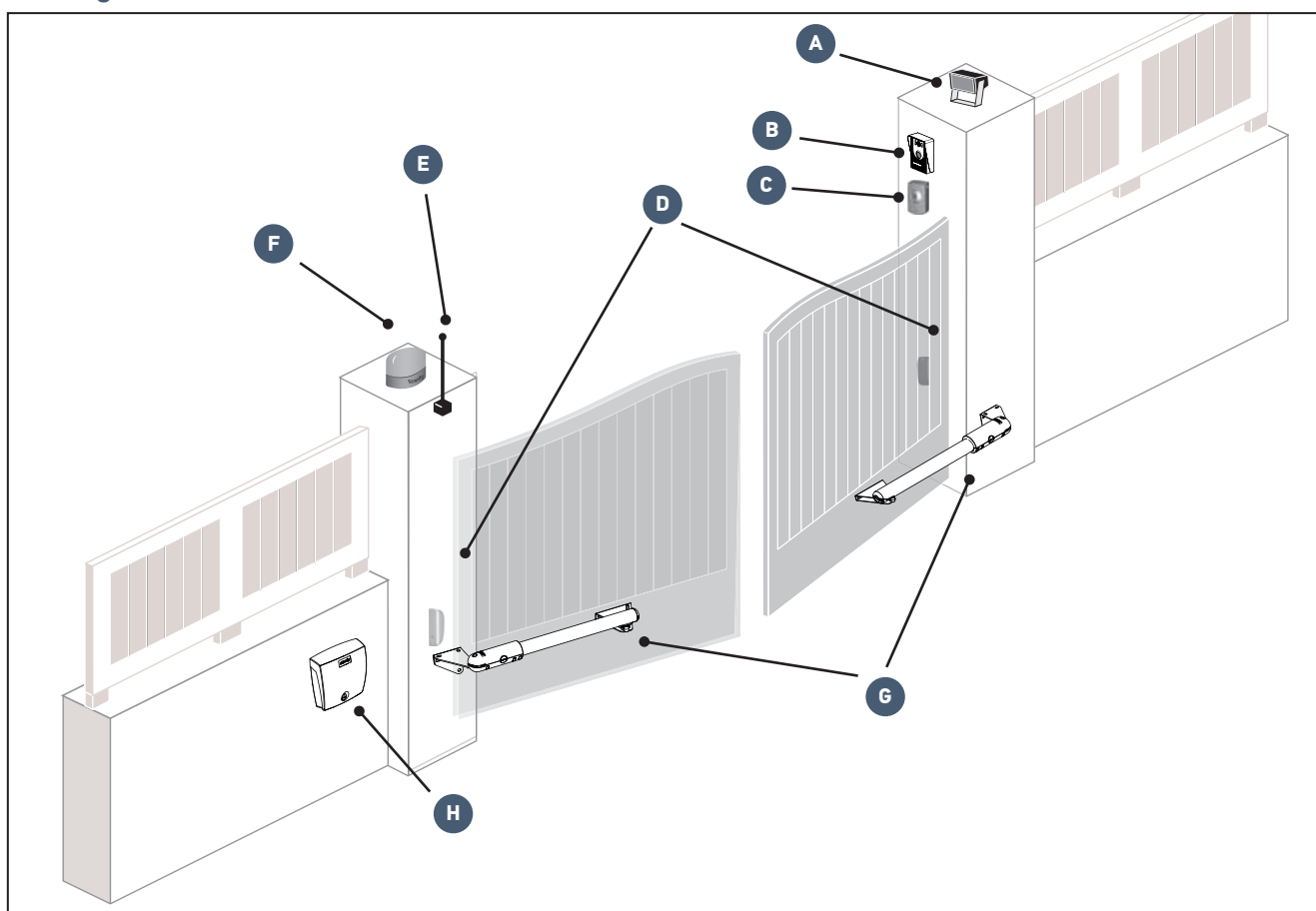

Repère	Désignation
A	Eclairage de zone*
B	Visiophone*
C	Contact à clé*
D	Cellules photoélectriques

Repère	Désignation
E	Antenne déportée*
F	Feu clignotant
G	Moteurs
H	Boîtier de commande

*accessoires en option

► Présentation de l'électronique de commande

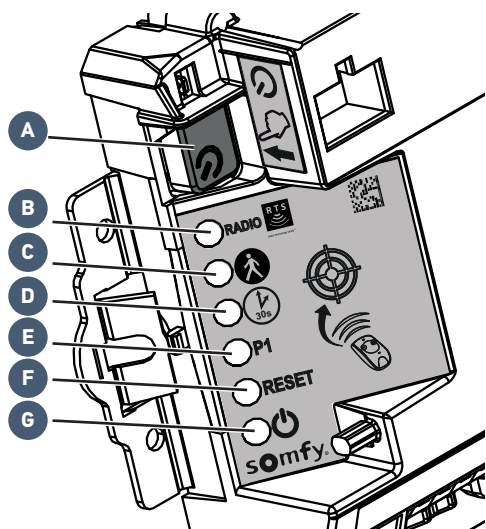

Rep.	Désignation	Fonction	
A	Bouton	Réveil de l'électronique de commande	
B	Voyant RADIO	S'allume à chaque fois que l'électronique de commande reçoit une commande radio	
C	Voyant	S'allume lors de l'activation/désactivation de l'ouverture piétonne	
D	Voyant	Allumé	la fermeture automatique du portail est activée
		Eteint	la fermeture automatique du portail n'est pas activée
		Clignote	le paramètre «fermeture automatique» est sélectionné
E	Voyant P1	Non utilisé	
F	Voyant RESET	Allumé	les réglages seuls ou les réglages et les points de commande radio sont effacés
		Clignote	la fonction d'effacement des réglages et des points de commande radio est sélectionnée
G	Voyant	Allumé	la motorisation fonctionne correctement - l'électronique de commande est réveillée
		Eteint	la motorisation fonctionne correctement - l'électronique de commande est en veille
		Clignote	voir «Diagnostic» page 31

► Pré-requis pour l'installation

► Points à vérifier avant l'installation

Portail

Le portail est en bon état : il s'ouvre et se ferme normalement sans forcer. Il reste horizontal pendant toute sa course. Il s'ouvre vers l'intérieur de la propriété.

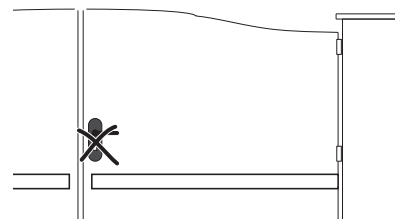
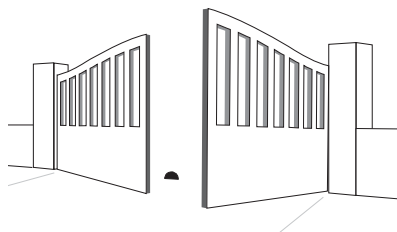
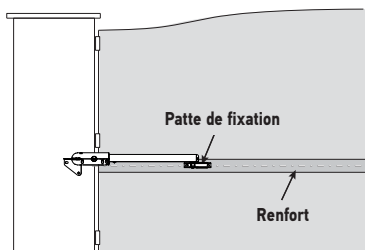

Renforts

Les moteurs doivent être fixés sur les renforts horizontaux des vantaux, idéalement placés à 1/3 de la hauteur du portail.

En l'absence de renforts, prévoir des contre-plaques en métal d'environ 4 mm d'épaisseur.

Butées de fermeture au sol

La course du portail en fermeture doit être délimitée par des butées fixées solidement au sol.

Les butées d'ouverture sont intégrées au moteur (voir «Réglage de la butée d'ouverture» page 19).

Serrure mécanique

Si le portail est équipé d'une serrure mécanique, elle doit être enlevée.

Piliers

Les piliers doivent avoir une structure robuste et une largeur d'au moins 21 cm. Dans le cas contraire, des aménagements sur le pilier peuvent être nécessaires pour assurer une bonne implantation et une bonne tenue de l'équerre.

Il est déconseillé de fixer l'équerre au ras du pilier : risque d'éclatement.

► Pré-équipement électrique

Câbles à prévoir

- Alimentation secteur : câble 3 x 1,5 mm² ou 3 x 2,5 mm² pour un usage extérieur (type H07RN-F mini).
- Liaison entre les moteurs : câble 2 x 1 mm²; prévoir une boîte de dérivation IP 55 pour protéger la liaison entre le câble qui sort du moteur et la rallonge qui va au boîtier de commande.
- Liaison des cellules : câble 2 x 0,75 mm².



Le passage du câble d'alimentation doit être prévu suivant les normes électriques en vigueur dans le pays d'utilisation.

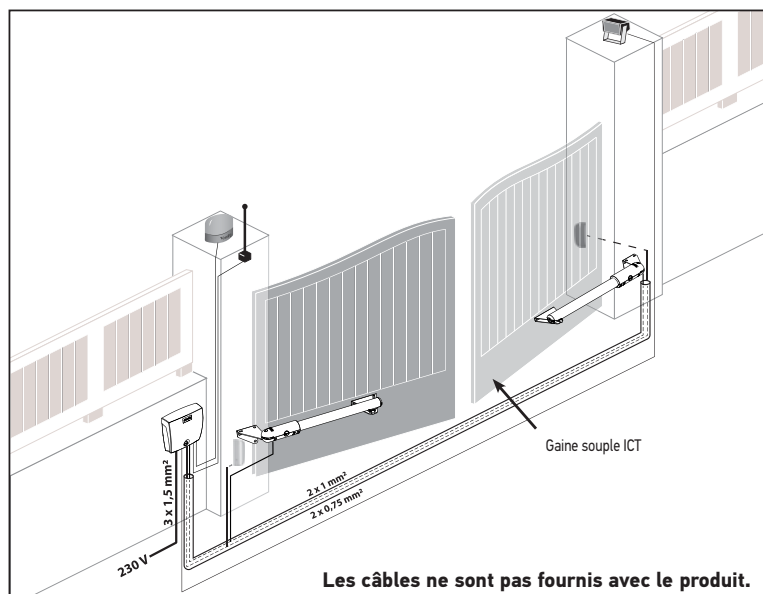
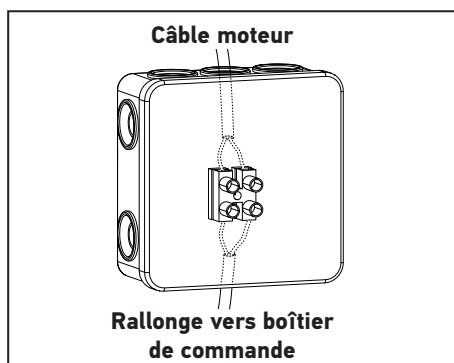

Passage des câbles

- Les câbles enterrés doivent être équipés d'une gaine de protection de diamètre suffisant pour passer tous les câbles.
- Aménager une arrivée électrique 230 V au plus près de l'emplacement du boîtier de commande.

► Câbles à prévoir



Si la réalisation d'une tranchée n'est pas possible, utiliser un passe-câble qui pourra supporter le passage des véhicules (réf. 2400484).



Le détail des câblages est donnée dans la partie «Câblage des accessoires» page 22.

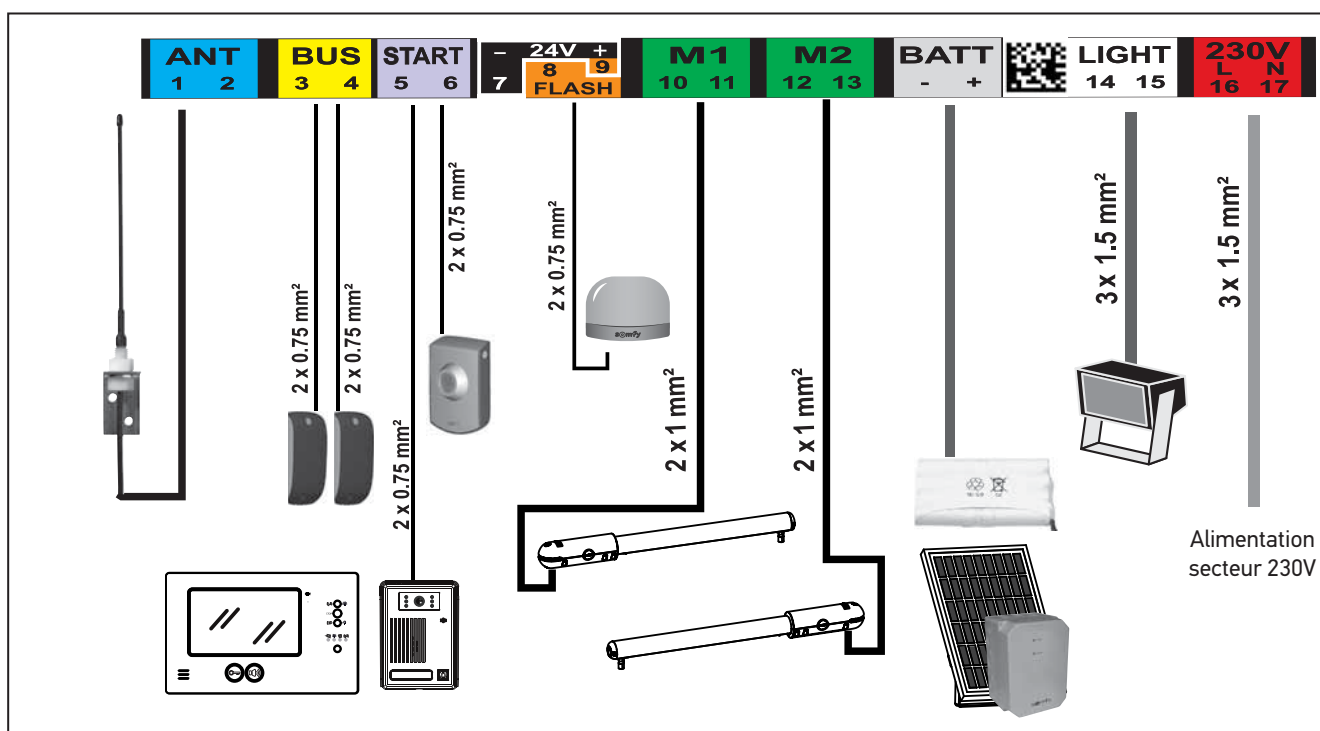

► Outillage nécessaire à l'installation (non fourni)

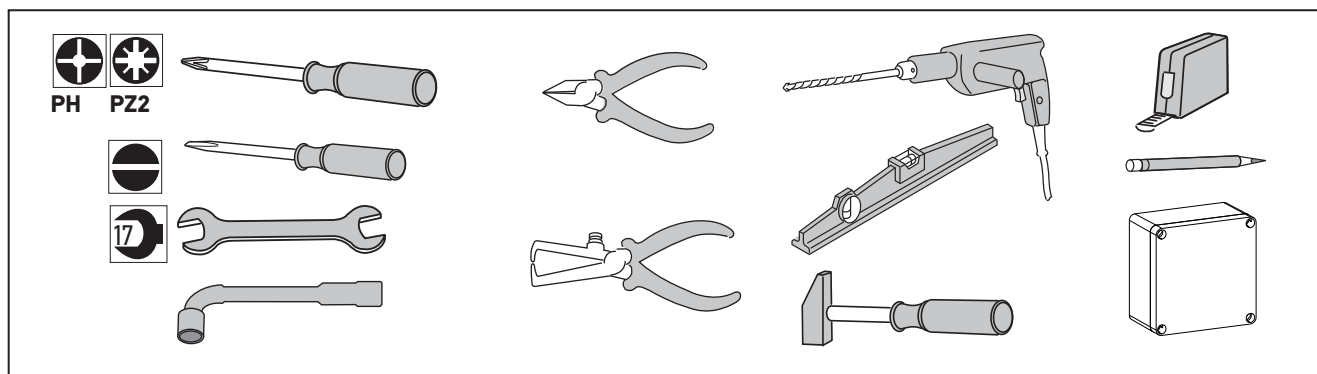

► Visserie nécessaire à l'installation (non fournie)

Ces informations sont données à titre indicatif.

Pour la fixation des ...		Quantité
PATTES AUX PILIERS/MURS		
	Visserie adaptée au matériau du pilier/mur (vis, goujons, scellements chimiques, ...): - diamètre : 8 à 10 mm - tête hexagonale	6
	Rondelles : - diamètre intérieur : 8 à 10 mm - diamètre extérieur : 16 à 20 mm Ecrous : - diamètre : 17 mm	6
PATTES AUX VANTAUX		
	Visserie adaptée au matériau du renfort des vantaux : - diamètre : 8 mm - longueur adaptée à l'épaisseur du renfort des vantaux	6
	Rondelles fournies - diamètre intérieur : 8 mm - diamètre extérieur : 22 mm	6
BOÎTIER DE COMMANDE		
	Visserie adaptée au matériau du pilier/mur - vis diamètre : 3,5 à 4,5 mm - tête fraisée ou bombée - chevilles type «S» pour béton : S5, S6 ou S8	4

1.1 Relever les cotes

Relever les cotes en utilisant le disque (f) pour déterminer la position des moteurs sur les piliers.

Nota : Pour ces mesures, les vantaux et leurs gonds sont considérés dans le même axe.

Rappel : Laisser une distance de 50 cm minimum entre les vantaux et les parties fixes (voir «Prévention des risques» page 4).

1 Mesurer la cote A.

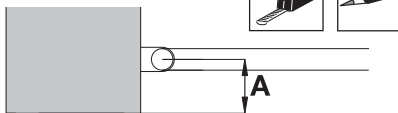

Reporter la cote A mesurée sur le disque.

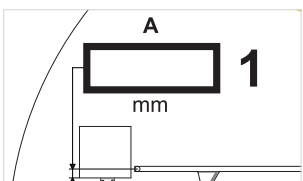

ATTENTION
Cotes déconseillées pour les vantaux > à 2 mètres

3 Déterminer la cote B

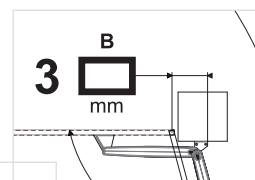

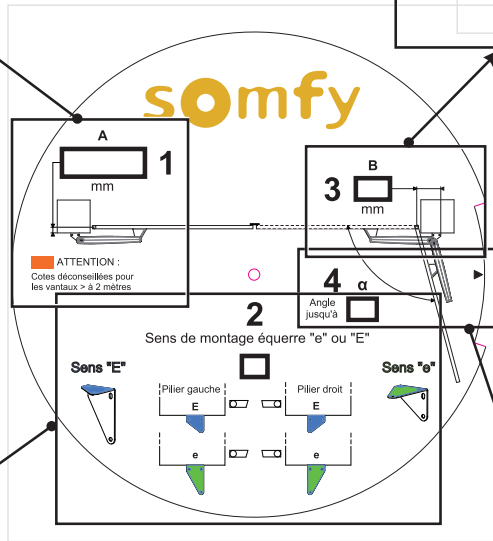

ATTENTION :
Cotes déconseillées pour les vantaux > à 2 mètres

Angle jusqu'à α

Sens de montage équerre "e" ou "E"

Sens "E" Pilier gauche Pilier droit Sens "e"

2 Le sens de montage (e ou E) de la patte de fixation du vérin au pilier est indiqué.

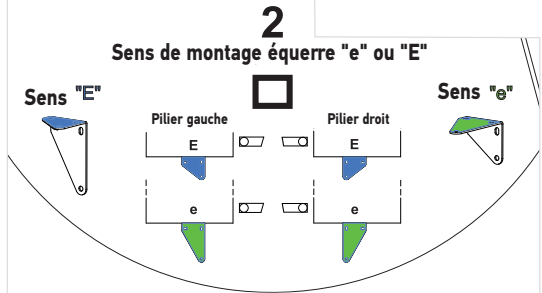

ATTENTION

Attention au sens de fixation haut et bas de la patte.



Sens correct



Sens incorrect

4 L'angle d'ouverture α maximum est indiqué.

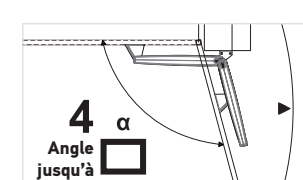

ATTENTION

Respecter l'angle d'ouverture maximum donné par le disque.



Conseil : la cote A est négative

Si la cote A est négative, le gond du vantail se trouve devant le pilier. Nous conseillons d'ajouter une cale de sorte que la patte de fixation vérin se trouve dans l'axe du gond du vantail et que A soit égal à 0 cm.

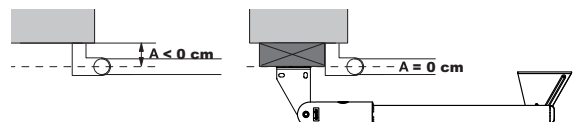

1.2 Fixation des pattes pilier

► Tracer les axes AM et AH

1. Reporter la cote B sur le pilier à partir de l'axe du gond et tracer un axe vertical AM sur le pilier.
2. Tracer l'axe horizontal AH sur le pilier à mi-hauteur du renfort.



Auto-contrôle avant l'étape suivante
Avez-vous bien tracé les axes AM et AH ?

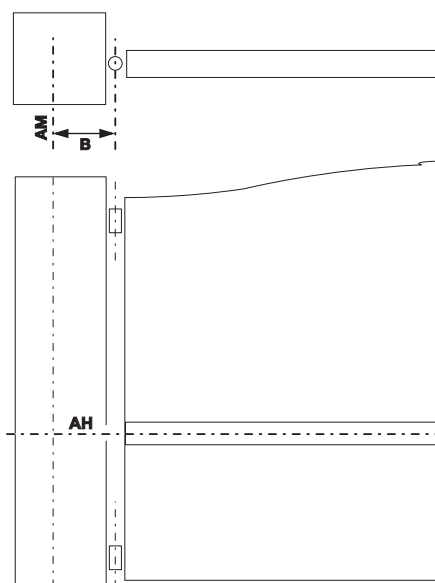

► Percer les piliers

1

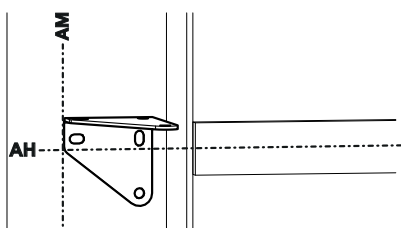

Aligner les repères tracés sur la patte sur l'axe AH et aligner le bord de la patte par rapport à l'axe AM.

Nota : Les repères tracés sur la patte se trouvent sous les trous oblongs.



Positionner la patte dans le sens e ou E défini à l'étape 2 du relevé de cotes (voir page 12).

Pilier gauche

Sens E

Sens e

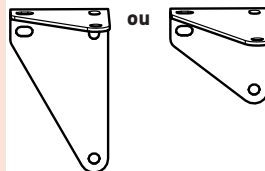

Pilier droit

Sens e

Sens E

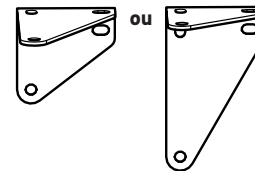

Attention au sens de fixation haut et bas de la patte.

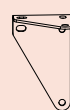

Sens correct

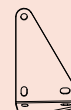

Sens incorrect

2

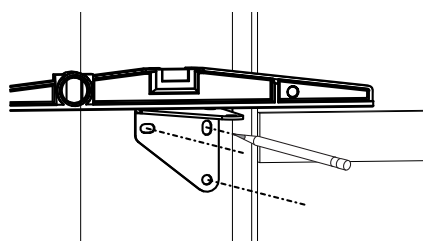

Vérifier l'horizontalité de la patte puis marquer les trous de fixation de la patte.

3

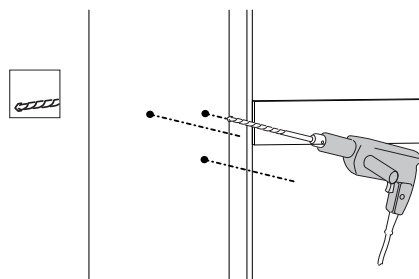

Percer 3 trous sur chaque pilier aux emplacements repérés (voir page 11 pour diamètre de perçage correspondant à une visserie adaptée).

► Fixer la patte de fixation pilier

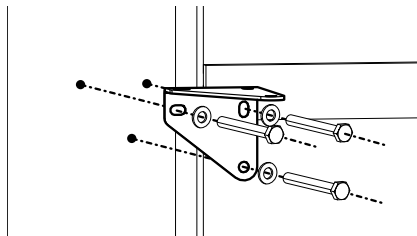
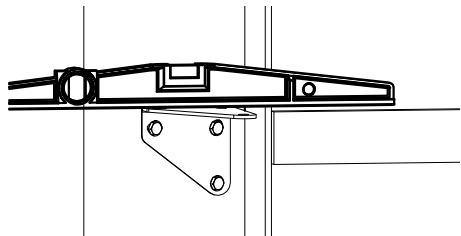
<p>1</p>  <p>Fixer la patte de fixation au pilier avec une visserie adaptée au support de fixation.</p>	<p>2</p>  <p>Vérifier le niveau de la patte. Reprendre le serrage si nécessaire.</p>
---	---



Auto-contrôle avant l'étape suivante

Avez-vous vérifié la parfaite horizontalité des pattes sur les piliers ?

► Monter le vérin sur la patte de fixation

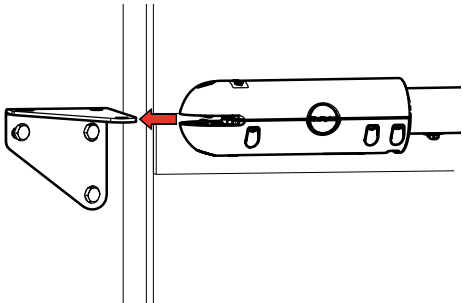
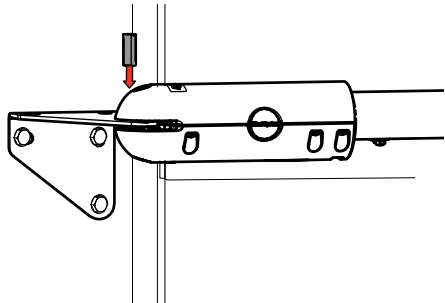
<p>1</p>  <p>Monter le vérin sur la patte de fixation.</p>	<p>2</p>  <p>Le bloquer avec l'axe (j).</p>
---	---

1.3 Fixation des moteurs aux vantaux

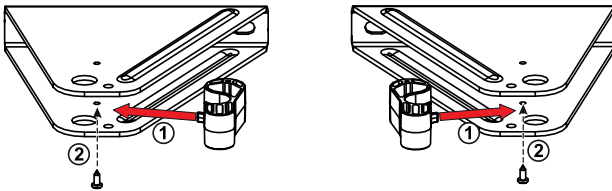
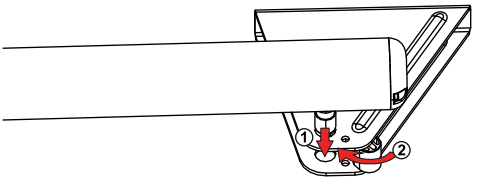
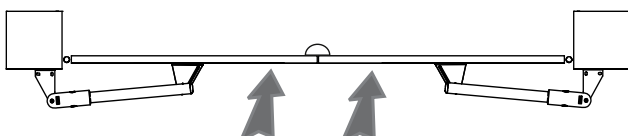

Ne jamais faire fonctionner le vérin avant d'avoir terminé sa fixation sur le vantail. Le réglage de la butée interne du vérin pourrait être faussé et des dysfonctionnements pourraient en résulter.

<p>1</p>  <p>Fixer la pièce de déverrouillage (h) sur la patte de fixation vantail (e) à l'aide de la vis (i).</p>	
<p>2</p>  <p>Monter le vérin sur la patte de fixation vantail. Clipser la pièce de déverrouillage sur le doigt d'entraînement du vérin pour le bloquer.</p>	
<p>3</p>  <p>Fermer le portail.</p>	<p>!</p> <p>En position fermée, les vantaux doivent être bien plaqués contre la butée au sol et le vérin sur sa butée interne.</p>

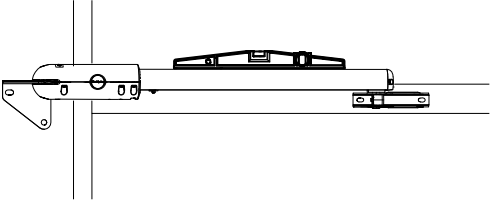
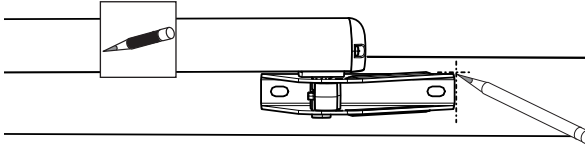
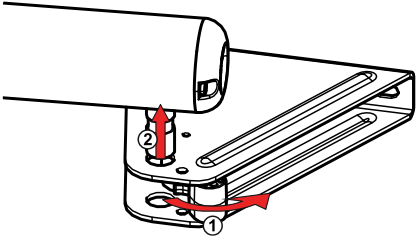
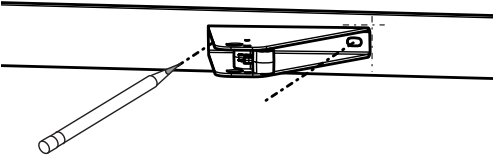
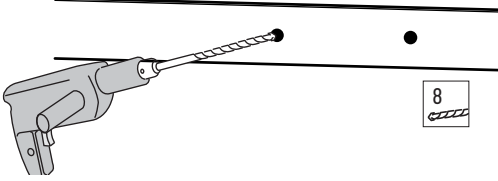
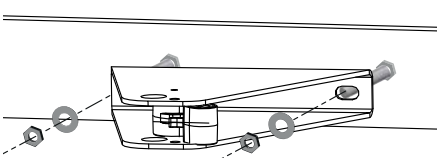
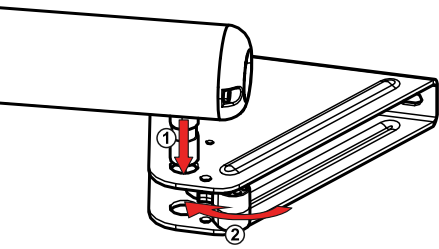
<p>4</p> 	<p>Plaquez la patte de fixation vantail contre le renfort des vantaux. Vérifier l'horizontalité du vérin.</p>
<p>5</p> 	<p>Marquer les repères sur les côtés de la patte de fixation vantail.</p>
<p>6</p> 	<p>Déclipser la pièce de déverrouillage puis retirer le vérin de la patte de fixation vantail.</p>
<p>7</p> 	<p>Repositionner la patte de fixation vantail puis marquer les trous de fixation au centre des trous oblongs.</p>
<p>8</p> 	<p>Percer les vantaux au diamètre 8.</p>
<p>9</p> 	<p>Fixer la patte de fixation vantail aux deux points sur les vantaux en utilisant des vis adaptées au matériau du renfort et les rondelles (k) fournies.</p> <div style="border: 1px solid red; padding: 5px; margin-top: 10px;"> <p>! Les rondelles (k) fournies doivent impérativement être montées.</p> </div>
<p>10</p> 	<p>Installer le vérin. Clipser la pièce de déverrouillage sur le doigt d'entraînement pour le bloquer.</p>

Auto-contrôle avant l'étape suivante
Avez-vous vérifié la parfaite horizontalité des vérins ?

1.4 Installation du boîtier de commande

► Position du boîtier de commande

Le boîtier sera monté sur un pilier/mur du côté de l'arrivée de l'alimentation électrique.

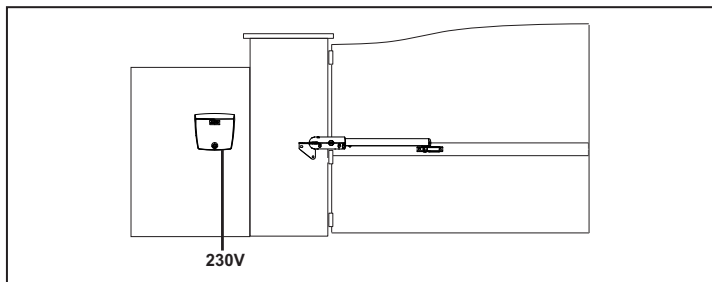

► Installer le cordon d'étanchéité

Emboîter le cordon d'étanchéité (m) dans le haut du boîtier de commande.

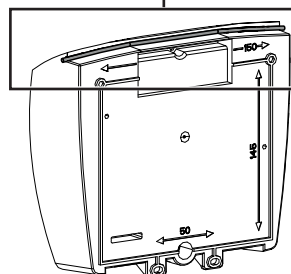
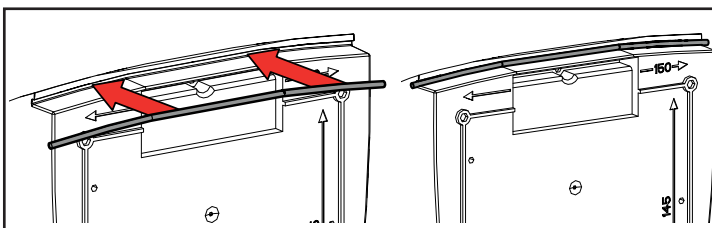

► Vérifier la position de l'antenne

Le bon positionnement de l'antenne est essentiel pour un fonctionnement optimal.



Ne jamais recouper le fil d'antenne.

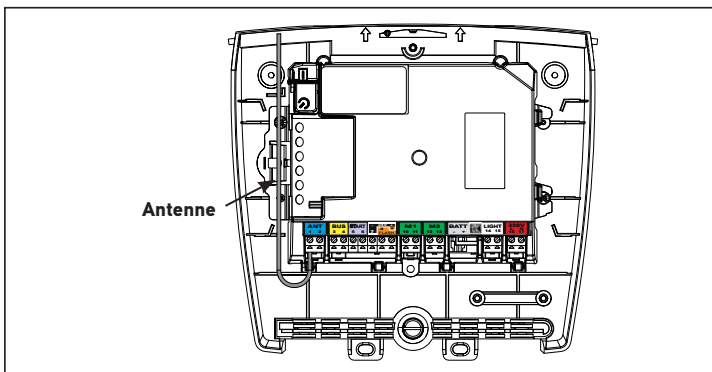

► Fixer le boîtier de commande

<p>1</p>	<ul style="list-style-type: none"> • Placer l'équerre de fixation du boîtier (p) contre le pilier/mur. • Vérifier son horizontalité en posant un niveau à l'emplacement prévu. • Marquer les points de fixation de l'équerre.
<p>2</p>	<p>Retirer l'équerre et percer le pilier/mur. Le diamètre de perçage est à définir en fonction du type de vis utilisées pour la fixation (voir page 11).</p>

3



Fixer l'équerre au pilier/mur.

4

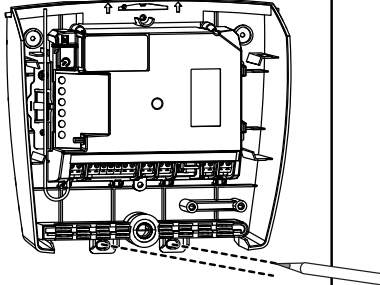

Placer le fond du boîtier pour marquer les 2 points de fixation en bas du boîtier.

5

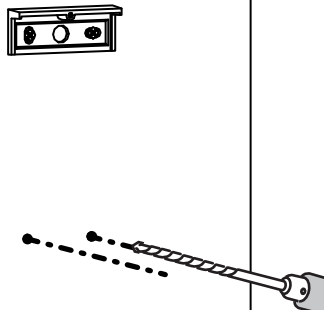

Retirer le fond du boîtier puis percer le pilier/mur. Le diamètre de perçage est à définir en fonction du type de vis utilisées pour la fixation (voir page 11).

6

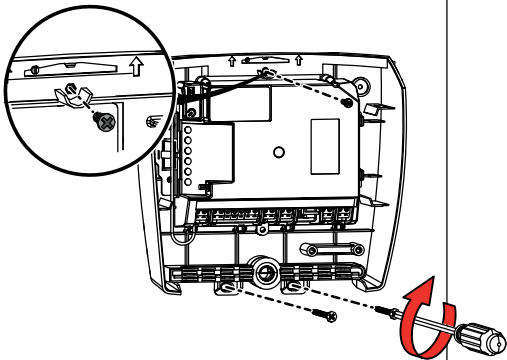

Fixer le fond du boîtier au pilier/mur : 1 vis (q) pour fixer le boîtier à l'équerre + 2 vis pour fixer le boîtier au pilier/mur.

1.5 Raccordement des moteurs



Le moteur M1 actionne le vantail qui :

- s'ouvre en premier et se referme en dernier,
- s'ouvre pour l'ouverture piétonne du portail.

1

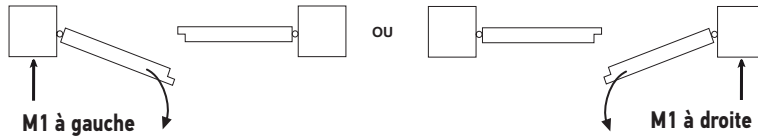

Portail fermé, identifier le vantail qui devra s'ouvrir en premier.
Le moteur M1 actionne ce vantail.

2

Connecter les moteurs comme indiqué dans le tableau ci-dessous :

Brancher le fil du moteur ...		sur la borne ...
M1	bleu	10
	marron	11
M2	bleu	12
	marron	13

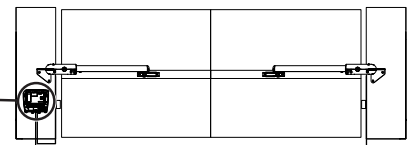
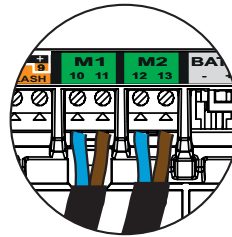

1.6 Raccordement à l'alimentation secteur



Pour votre sécurité, ces opérations doivent se faire hors tension.

Utiliser un câble 3 x 1,5 mm² pour un usage extérieur (type H07RN-F minimum).

Utiliser impérativement le serre-câble fourni. Pour tous les câbles basse tension, s'assurer qu'ils résistent à une traction de 100 N.

Vérifier que les conducteurs n'ont pas bougé après avoir appliqué cette traction.

1

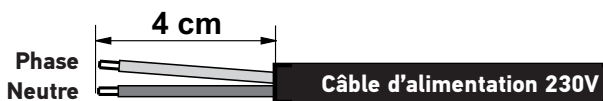

Sur un câble de type 3 x 1,5 mm², préparer 2 fils de 4 cm (phase et neutre).

2

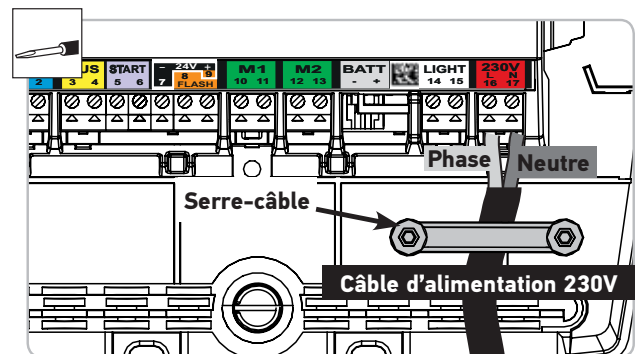

- Raccorder la phase et le neutre sur les bornes 16 et 17 (étiquette rouge «230 V»).
- Bloquer le câble d'alimentation 230 V avec le serre-câble fourni (r).
- Mettre un domino sur le fil de terre (jaune/vert) et le ranger dans le boîtier de commande.

2.1 Mettre l'installation sous tension

Le voyant  clignote (2 fois).

La motorisation est sous tension et en attente d'auto-apprentissage.

Si le voyant  ne s'allume pas ou que le nombre de clignotements n'est pas celui attendu : voir «Diagnostic» page 31.

2.2 Réglage de la butée d'ouverture



Butées d'ouverture

Les butées d'ouverture sont intégrées au vérin. Elles délimitent la course du portail à l'ouverture.

Rappel : L'installation doit être équipée de butées de fermeture fixées au sol pour délimiter la course du portail à la fermeture.

Durant cette phase, un appui sur la touche 1 de la télécommande programmée n'entraînera que l'ouverture et l'arrêt du portail (1er appui = ouvre, 2ème appui = stop, 3ème appui = ouvre, 4ème appui = stop, etc.) la position d'ouverture souhaitée peut ainsi être réglée en plusieurs fois. La fermeture du portail sera possible une fois les butées d'ouverture installées.

1		<ul style="list-style-type: none"> • Appuyer sur la touche 1 de la télécommande. Après quelques secondes, le premier vantail s'ouvre, en petite vitesse. Si le vantail ne s'ouvre pas, vérifier que les moteurs sont câblés comme indiqué page 18. • Appuyer à nouveau sur la touche 1 de la télécommande pour arrêter le vantail à la position d'ouverture souhaitée.
2		<p>Positionner les butées d'ouverture en contact avec la noix du vérin puis serrer les butées avec une clé allen 6 pans diamètre 3 (2 vis par butée).</p> <div style="border: 1px solid red; padding: 5px; display: inline-block;">  Faire 2 tours de clé après contact. </div>
3		<p>Appuyer sur la touche 1 de la télécommande. Le second vantail s'ouvre.</p>
4		<p>Appuyer à nouveau sur la touche 1 de la télécommande pour arrêter le vantail à la position d'ouverture souhaitée.</p>

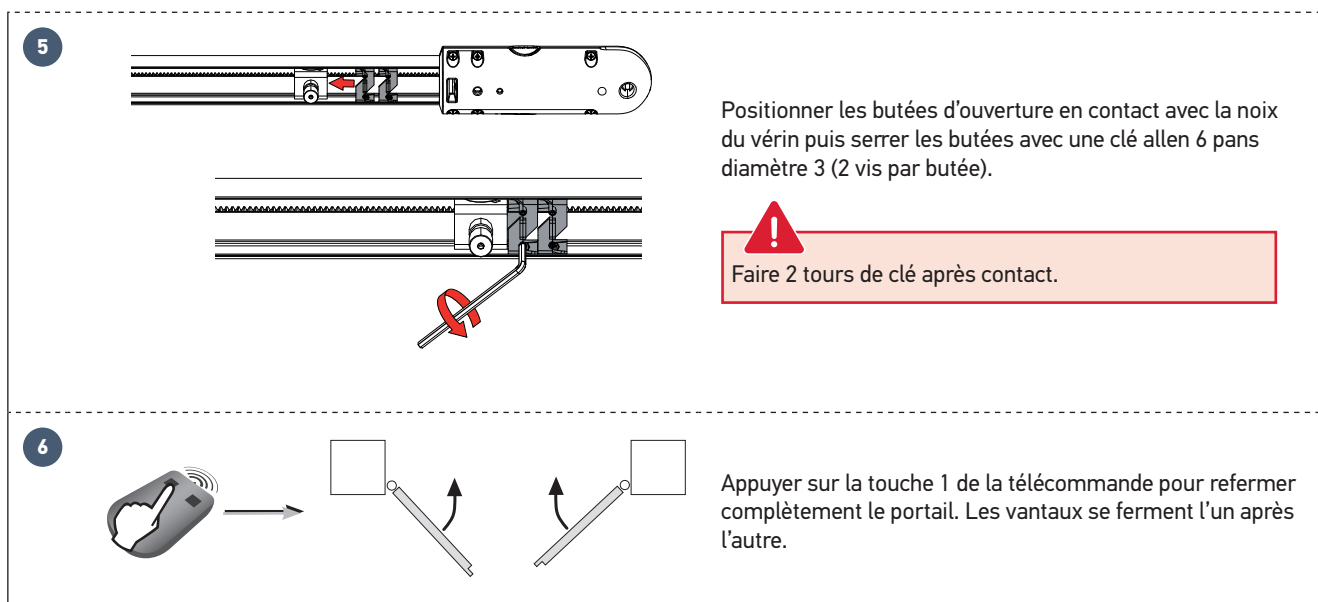

Auto-contrôle avant l'étape suivante
Avez-vous réglé la position de la butée d'ouverture sur chaque moteur ?

2.3 Auto-apprentissage de la course du portail

Vérifier que l'installation est sous tension : le voyant clignote (2 fois).

Cas 1 : Première mise en service de votre motorisation

Appuyer sur la touche 1 de la télécommande pour lancer un mouvement COMPLET d'ouverture du portail.

Lorsque le portail est complètement ouvert, appuyer une nouvelle fois sur la touche 1 de la télécommande pour lancer un mouvement COMPLET de fermeture du portail.

Lorsque le portail est complètement fermé, le voyant du boîtier de commande doit S'ALLUMER FIXE.

Cas 2 : Vous venez d'effacer les réglages

Lancer 4 mouvements complets d'ouverture et fermeture du portail.

A la fin des 4 mouvements, le voyant du boîtier de commande doit S'ALLUMER FIXE.

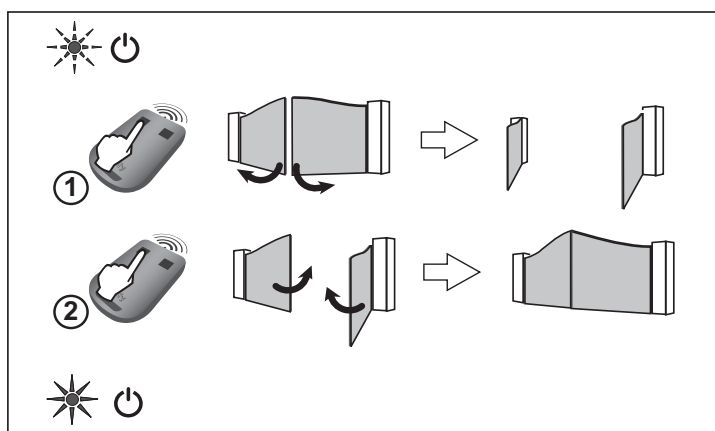

Les mouvements du portail ne doivent pas être interrompus (ouverture /fermeture complète).
S'ils sont interrompus, l'apprentissage reprendra automatiquement à la prochaine ouverture commandée.

Si le voyant clignote, relancer l'auto-apprentissage de la course des vantaux (4 mouvements complets d'ouverture et fermeture).

Si le voyant continue à clignoter consulter «Diagnostic» page 31.

Si le portail se réouvre à la fin du mouvement de fermeture, desserrer et décaler légèrement les pattes des vantaux vers le centre du portail.



AVERTISSEMENT

A la fin de l'installation, vérifier impérativement que la détection d'obstacle est conforme à l'annexe A de la norme EN 12 453.

2.4 Fermer le boîtier de commande

1

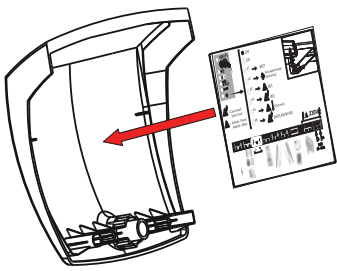

Coller l'étiquette mémo (g) au fond du couvercle du boîtier de commande.

2

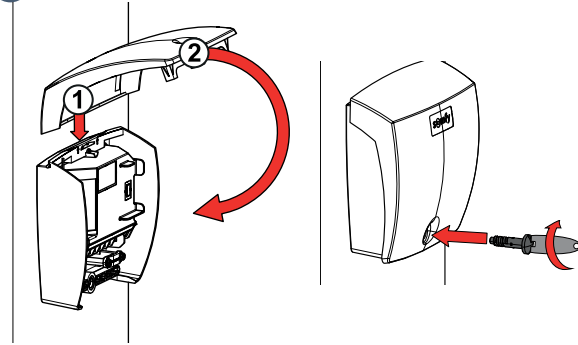

Fermer le boîtier de commande et visser le couvercle.

2.5 Mise en veille/Réveil de l'électronique de commande



Lorsque l'auto-apprentissage a été effectué, l'électronique passe automatiquement en veille après 5 minutes d'inactivité, pour faire des économies d'énergie.
En état de veille, tous les voyants sont éteints.

Pour vérifier si la motorisation est sous tension ou pour vérifier/modifier le paramétrage, appuyer 2 secondes sur le bouton  pour réveiller l'électronique. L'électronique repassera automatiquement en veille après 5 minutes d'inactivité.

2.6 Ouverture totale et fermeture du portail



Les télécommandes livrées dans le kit sont déjà mémorisées et programmées pour que la touche 1 des télécommandes commande l'ouverture totale du portail.



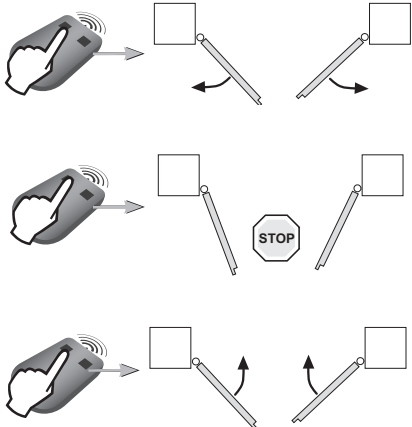

- Portail fermé : appuyer sur la touche 1 de la télécommande pour ouvrir totalement le portail.
- Portail en mouvement : appuyer sur la touche 1 de la télécommande pour arrêter le portail.
- Portail ouvert : appuyer sur la touche 1 de la télécommande pour fermer le portail.

2.7 Détection d'obstacle

Si un obstacle est détecté (effort anormal sur la motorisation) :

- Pendant l'ouverture du portail : le portail s'arrête.
- Pendant la fermeture du portail : le portail s'arrête et se ré-ouvre.

2.8 Formation des utilisateurs

Former tous les utilisateurs à l'usage en toute sécurité de ce portail motorisé (utilisation standard et principe de déverrouillage) et aux vérifications périodiques obligatoires.



Pour votre sécurité, ces opérations doivent se faire hors tension.



Il est conseillé de réaliser l'auto-apprentissage de la course du portail avant de raccorder les accessoires (cellules photoélectriques, feu clignotant, etc.).

3.1 Cellules photoélectriques



Le câblage d'un second jeu de cellules photoélectriques n'est pas possible sur cette motorisation.

► Installation

Après le câblage des cellules photoélectriques :

- remettre le moteur sous tension,
- lancer un mouvement d'ouverture ou de fermeture du portail.

Les cellules photoélectriques sont reconnues par l'électronique de commande à la fin de ce mouvement.

► Fonctionnement avec des cellules photoélectriques

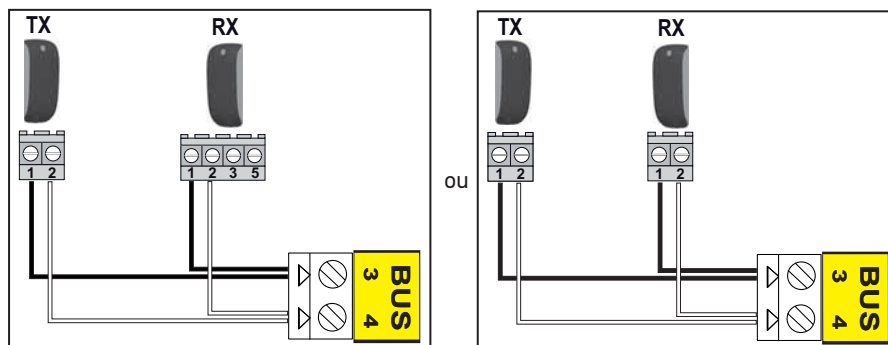

Si les cellules sont occultées pendant la fermeture du portail, le portail s'arrête et se ré-ouvre.

► En cas de suppression des cellules photoélectriques

Après la suppression des cellules photoélectriques, remettre le moteur sous tension puis réaliser la procédure «Désactiver la fermeture automatique» page 26.

3.2 Feu clignotant



Ampoule 10 W - 24 V MAXIMUM - L'utilisation d'ampoule de puissance supérieure à 10 W - 24 V peut provoquer des dysfonctionnements de la motorisation.

► Fonctionnement du feu clignotant

Le feu clignote pendant le mouvement du portail.

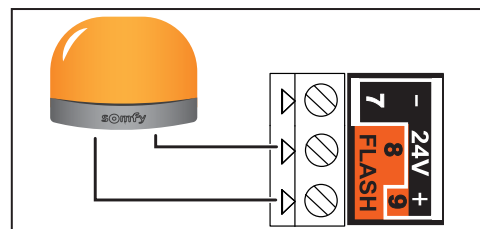

3.3 Batterie (option)



Cet accessoire est incompatible avec une alimentation solaire.



Pour augmenter l'autonomie de la batterie en fonctionnement, les commandes filaires sont désactivées; seuls les télécommandes et points de commande radio permettent de commander le portail.

La batterie de secours assure le fonctionnement du portail en cas de défaillance électrique.

Le voyant  clignote (1 clignotement) lorsque le moteur fonctionne sur batterie.

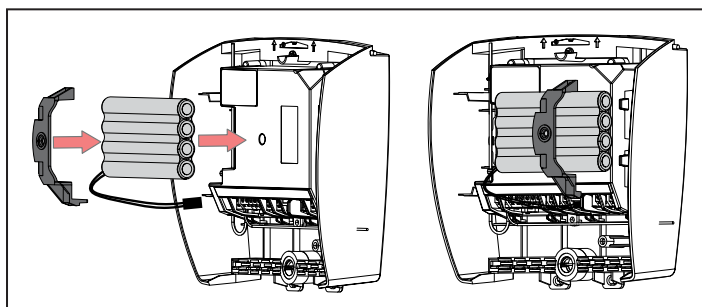

► Caractéristiques techniques de la batterie

- Autonomie : 10 cycles en continu ou 24 heures sur un portail en parfait état.
- Temps de charge avant utilisation optimale de la batterie : 48 heures.
- Durée de vie : 3 ans.

Pour une durée de vie optimale de la batterie, couper l'alimentation électrique du portail au moins 3 fois par an pour le faire fonctionner quelques cycles sur la batterie.

3.4 Antenne déportée (option)



Une antenne déportée de plus longue portée peut remplacer l'antenne fil. Elle se place sur le haut du pilier, elle doit être dégagée.

Elle est raccordée aux bornes 1 et 2 (étiquette bleu «ANT») du boîtier de commande :

- l'âme du fil en borne 1,
- la tresse de masse en borne 2.

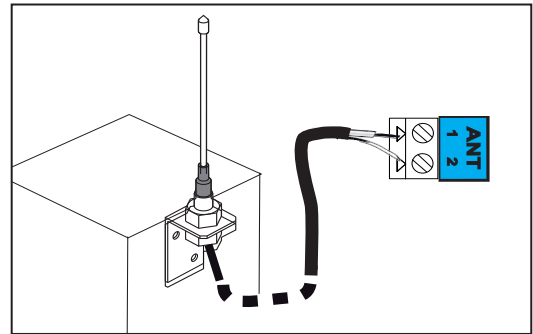

3.5 Visiophone (option)



Cet accessoire est incompatible avec une alimentation solaire. Ne raccorder qu'un contact sec non alimenté.

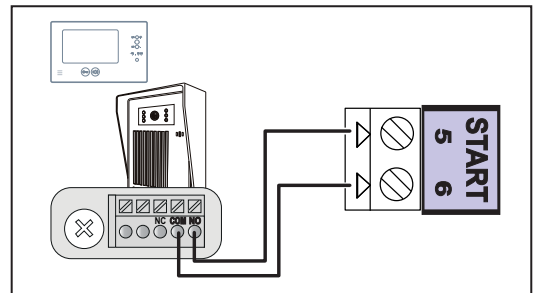

3.6 Contact à clé (option)



Cet accessoire est incompatible avec une alimentation solaire.

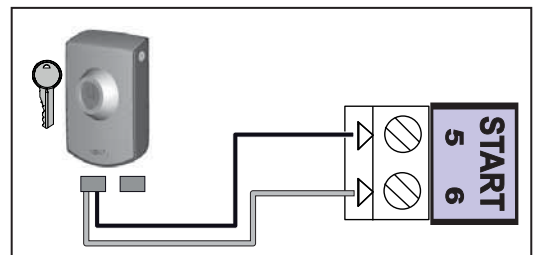

3.7 Eclairage de zone (option)



Cet accessoire est incompatible avec une alimentation solaire. Utiliser uniquement des ampoules halogènes ou incandescences pour l'éclairage de zone, 500 W maximum.

► Fonctionnement de l'éclairage de zone

L'éclairage de zone s'allume à chaque mise en route de la motorisation. Il s'éteint automatiquement 1 minute 30 après la fin du mouvement.

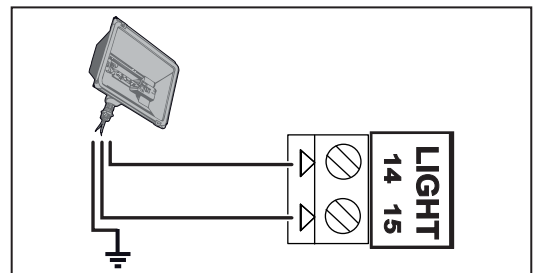

3.8 Alimentation solaire (option)



Ne jamais brancher le moteur à une alimentation 230 V pendant qu'il est branché à une alimentation solaire, le boîtier électronique du moteur risquerait d'être endommagé.

Lorsque le moteur fonctionne sur l'alimentation solaire :

- seuls les télécommandes et points de commande radio permettent de commander le portail (les commandes filaires sont désactivées),
- les accessoires de sécurité filaires restent activés (cellules photoélectriques, feu clignotant).

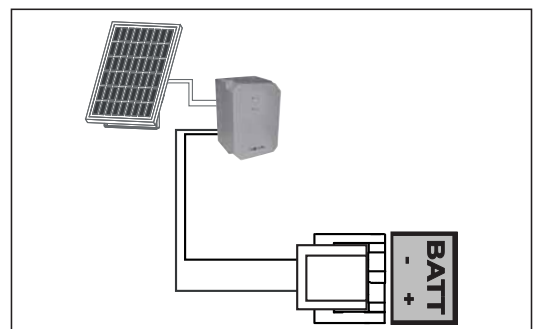

4.1 Ouverture piétonne

► Fonctionnement de l'ouverture piétonne

Ouverture piétonne (moteur M1) par un appui sur la touche activée.

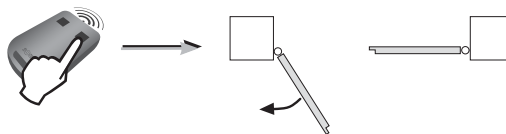

Arrêt en cours de mouvement par un nouvel appui sur la touche activée.

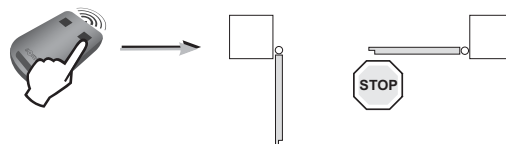

Fermeture par un nouvel appui sur la touche activée.

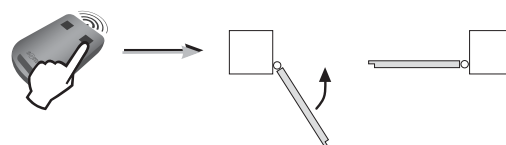



► Activer l'ouverture piétonne



La touche 1 des télécommandes 2 ou 4 touches ne peut pas être programmée pour commander l'ouverture piétonne du portail. Voir «Présentation des télécommandes» page 27 pour plus d'informations.

1



Appuyer 2 s sur le bouton  de l'électronique de commande.
Le voyant  s'allume.

2

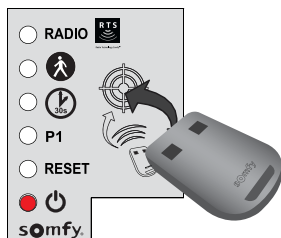

Poser la télécommande sur la cible de l'électronique de commande.

3

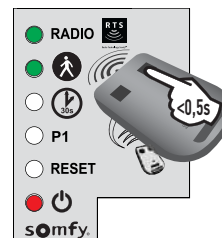

Appuyer sur la touche 2 de la télécommande.
Les voyants "RADIO" et  s'allument puis s'éteignent.

L'ouverture piétonne est activée sur cette touche.



Eloignez-vous de l'électronique de commande pour tester l'ouverture piétonne.

► Désactiver l'ouverture piétonne

Répéter la procédure "Activer l'ouverture piétonne" avec la touche pour laquelle l'ouverture piétonne doit être désactivée. Le voyant  s'allume puis s'éteint. L'ouverture piétonne est désactivée sur cette touche.

4.2 Fermeture automatique

► Fonctionnement de la fermeture automatique

Appuyer sur la touche 1 de la télécommande pour ouvrir le portail.









Le portail se referme après 30 secondes ou 5 secondes si un passage est détecté par les cellules photoélectriques.

La fermeture automatique du portail peut être interrompue en appuyant sur la touche 1 de la télécommande. Pour ensuite refermer le portail, appuyer à nouveau sur la touche 1 de la télécommande.

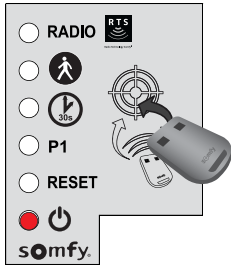
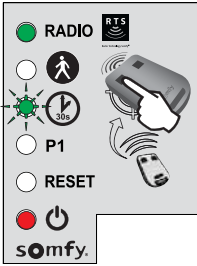

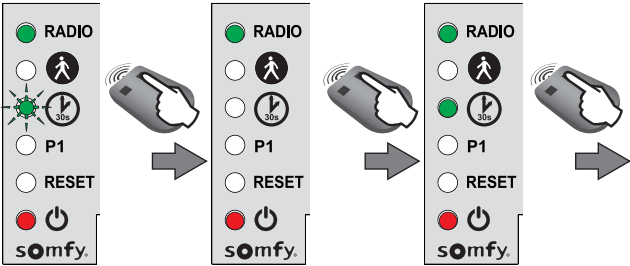

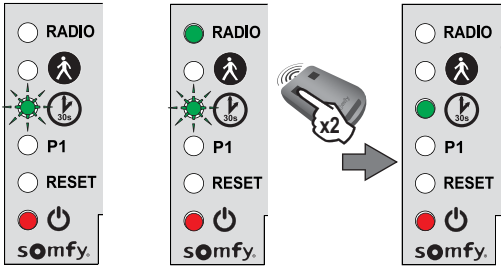



► Activer la fermeture automatique

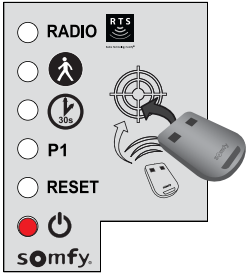
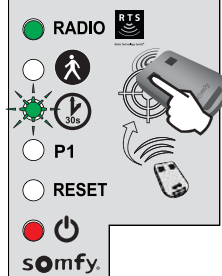

La fermeture automatique ne peut être activée que si des cellules photoélectriques sont câblées et reconnues par l'électronique de commande du moteur.

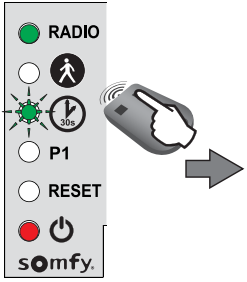
<p>1</p>  <p>Appuyer 2 s sur le bouton  de l'électronique de commande. Le voyant  s'allume.</p>	<p>2</p>  <p>Poser la télécommande sur la cible de l'électronique de commande.</p>	<p>3</p>  <p>Rester appuyé sur la touche 1 de la télécommande jusqu'à ce que le voyant  clignote.</p> <div data-bbox="1173 784 1412 1048" style="border: 1px solid orange; padding: 5px; margin-top: 10px;"> <p>i</p> <p>Une fois l'étape 3 réalisée, vous pouvez réaliser les étapes suivantes à distance (sans poser la télécommande sur la cible).</p> </div>
<p>4</p>  <p>Rester appuyé sur la touche 2 de la télécommande jusqu'à ce que le voyant  s'éteigne puis s'allume fixe.</p>		<p>5</p>  <p>Lorsque la touche 2 est relâchée, le voyant  clignote, appuyer 2 fois sur la touche 1 de la télécommande. Le voyant  reste allumé. La fermeture automatique est activée.</p>

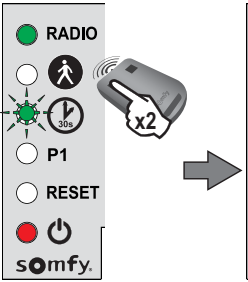
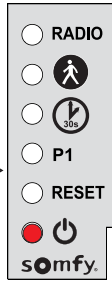
► Désactiver la fermeture automatique

<p>1</p>  <p>Appuyer 2 s sur le bouton  de l'électronique de commande. Le voyant  s'allume.</p>	<p>2</p>  <p>Poser la télécommande sur la cible de l'électronique de commande.</p>	<p>3</p>  <p>Rester appuyé sur la touche 1 de la télécommande jusqu'à ce que le voyant  clignote.</p>
<p>4</p>  <p>Appuyer sur la touche 2 de la télécommande. Le voyant  clignote.</p>	<p>5</p>  <p>Appuyer 2 fois sur la touche 1 de la télécommande.</p> <p>6</p>  <p>Le voyant  est éteint. La fermeture automatique est désactivée.</p>	

5.1 Présentation des télécommandes

Les télécommandes RTS Somfy peuvent commander, selon les choix de paramétrage :

- l'ouverture totale du portail
- l'ouverture piétonne du portail
- un autre équipement Somfy RTS (exemple : moteur de porte de garage, volet roulant, etc.)

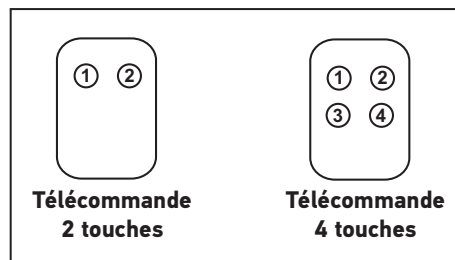

Les télécommandes livrées dans le kit sont déjà mémorisées et programmées pour que la touche 1 des télécommandes commande l'ouverture totale du portail.



Vous pouvez mémoriser jusqu'à 16 points de commande (télécommandes, autre point de commande radio). Si vous mémorisez un 17ème point de commande, le premier mémorisé sera automatiquement effacé.



Si vous souhaitez programmer une ouverture piétonne, elle doit forcément être programmée sur la touche suivant celle de l'ouverture totale (ex : ouverture totale commandée par la touche 2, ouverture piétonne commandée par la touche 3). La programmation de l'ouverture piétonne sur la touche 1 des télécommandes est impossible.

► Possibilités de programmation de la télécommande 2 touches

	Touche ①	Touche ②
Possibilité 1	Ouverture totale	Ouverture piétonne ou autre automatisme Somfy RTS
Possibilité 2	Autre équipement Somfy RTS	Ouverture totale

► Possibilités de programmation de la télécommande 4 touches

	Touche ①	Touche ②	Touche ③	Touche ④
Possibilité 1	Ouverture totale	Ouverture piétonne ou autre automatisme Somfy RTS	Autre automatisme Somfy RTS	Autre automatisme Somfy RTS
Possibilité 2	Autre automatisme Somfy RTS	Ouverture totale	Ouverture piétonne ou autre automatisme Somfy RTS	Autre automatisme Somfy RTS
Possibilité 3	Autre automatisme Somfy RTS	Autre automatisme Somfy RTS	Ouverture totale	Ouverture piétonne ou autre automatisme Somfy RTS
Possibilité 4	Autre automatisme Somfy RTS	Autre automatisme Somfy RTS	Autre automatisme Somfy RTS	Ouverture totale

► Utilisation d'une télécommande 3 touches

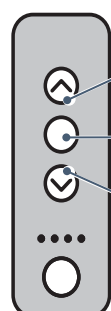

Ouverture

Pour ouvrir complètement le portail, appuyer sur la touche "Montée" de la télécommande.

Stop

Pour arrêter le portail en cours de mouvement, appuyer sur la touche centrale de la télécommande.

Fermeture

Pour fermer le portail, appuyer sur la touche "Descente" de la télécommande.



La télécommande 3 touches ne peut pas être utilisée pour modifier le paramétrage du moteur.

5.2 Ajouter une télécommande

► Télécommande 2 ou 4 touches

<p>1</p>  <p>Appuyer 2 s sur le bouton  de l'électronique de commande. Le voyant  s'allume.</p>	<p>2</p>  <p>Poser la nouvelle télécommande à programmer sur la cible de l'électronique de commande.</p>	<p>3</p>  <p>Faire un appui bref sur la touche de la télécommande à programmer. Le voyant "RADIO" s'allume puis s'éteint lorsque vous relâchez la touche de la télécommande. L'ouverture totale est programmée sur cette touche.</p>
---	--	---

► Télécommande 3 touches

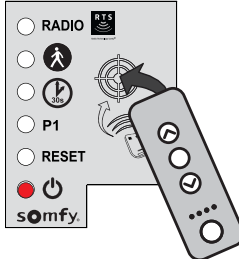
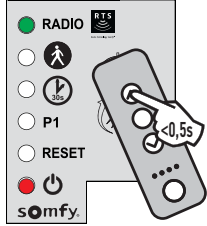
<p>1</p>  <p>Appuyer 2 s sur le bouton  de l'électronique de commande. Le voyant  s'allume.</p>	<p>2</p>  <p>Poser la nouvelle télécommande à programmer sur la cible de l'électronique de commande.</p>	<p>3</p>  <p>Faire un appui bref sur une touche de la télécommande à programmer. Le voyant "RADIO" s'allume puis s'éteint lorsque vous relâchez la touche de la télécommande. La télécommande est mémorisée.</p>
--	---	--

5.3 Supprimer les télécommandes

Voir «Effacer les réglages» page 30.



La motorisation doit être déconnectée de toute source d'alimentation durant le nettoyage, la maintenance et lors du remplacement des pièces.

6.1 Assistance





Si la panne persiste ou pour tout autre problème ou demande de renseignement sur votre motorisation, rendez-vous sur notre Forum d'entraide : forum.somfy.fr

La communauté est là pour vous répondre, et la réponse à votre question y figure peut être déjà !

Vous pouvez également prendre contact auprès d'un conseiller Somfy par téléphone au **0 820 055 055** (0.15€ la minute), disponibilité du service sur www.somfy.fr

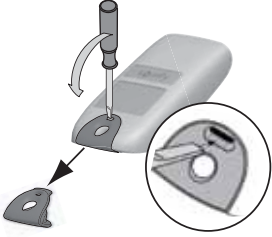
6.2 Changer la pile de la télécommande

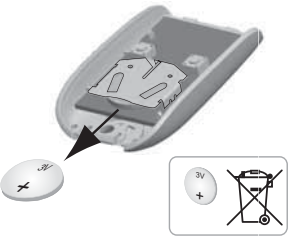





La durée de vie de la pile, généralement constatée, est de 2 ans.

<p>1</p>  <p>Retirer le clip de la télécommande.</p>	<p>2</p>  <p>Insérer le tournevis dans la fente et soulever le capot.</p>	<p>3</p>  <p>Retirer la pile à l'aide d'un tournevis.</p>	<p>4</p>  <p>Remplacer la pile (3 V CR 2430 ou CR 2032).</p>
---	--	---	---

6.3 Effacer les réglages

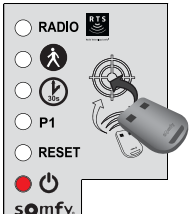
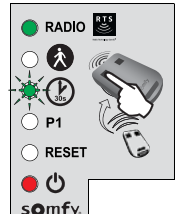
Dans quels cas effacer les réglages ?

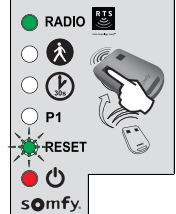
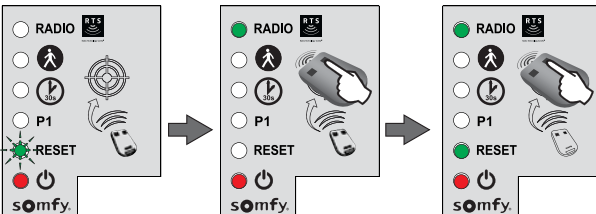
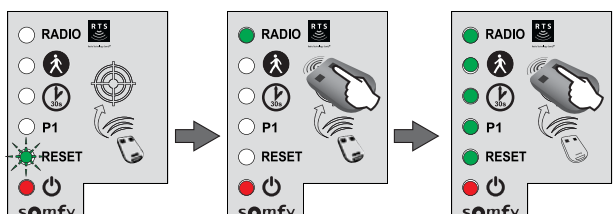
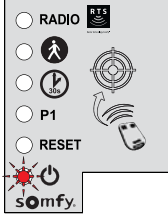
- Après l'apprentissage de la course du portail si vous changez la butée d'ouverture de position ou si vous modifiez le câblage des moteurs.
- En cas de réouvertures aléatoires du portail dues à une usure normale du portail.

<p>1</p>  <p>Appuyer 2 s sur le bouton  de l'électronique de commande. Le voyant  s'allume.</p>	<p>2</p>  <p>Poser la télécommande mémorisée sur la cible.</p>	<p>3</p>  <p>Rester appuyé sur la touche 1 de la télécommande jusqu'à ce que le voyant  clignote.</p>	<p>4</p>  <p>Appuyer 1 fois sur la touche 1 de la télécommande. Le voyant "RESET" clignote.</p>
<p>5 Pour effacer les réglages*</p>  <p>Rester appuyé sur la touche 2 de la télécommande jusqu'à ce que le voyant "RESET" s'allume.</p>		<p>5 Pour effacer les réglages* et les télécommandes/ points de commande mémorisés</p>  <p>Rester appuyé sur la touche 2 de la télécommande jusqu'à ce que tous les voyants s'allument.</p>	
<p>6</p> 		<p>Le voyant  clignote 2 fois (voir «Auto-apprentissage de la course du portail» page 20).</p>	



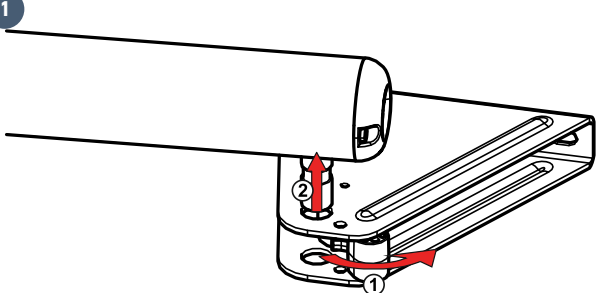
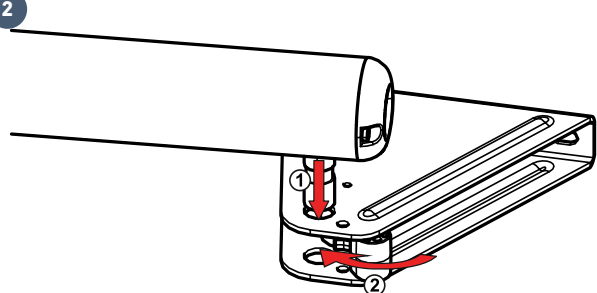

*Course du portail, désactivation des paramètres, ...

6.4 Déverrouiller / verrouiller les moteurs

En déverrouillant les moteurs, le portail peut être manoeuvré manuellement en cas de panne électrique.

<p>1</p>  <p>Déverrouillage des moteurs Déclipser la pièce de déverrouillage puis retirer le vérin de la patte de fixation vantail.</p>	<p>2</p>  <p>Verrouillage des moteurs Installer le vérin. Clipser la pièce de déverrouillage sur le doigt d'entraînement pour le bloquer.</p>
--	---

6.5 Diagnostic

DIAGNOSTIC		DÉPANNAGE
Les moteurs ne répondent pas aux commandes de la télécommande	Portée de la télécommande réduite	<ul style="list-style-type: none"> - Vérifier la pile de la télécommande (voir «Changer la pile de la télécommande» page 29). - Vérifier l'antenne du boîtier de commande (câblage, position, voir page 16). - Vérifier qu'il n'y a pas d'élément extérieur susceptible de perturber les émissions radio (pylône électrique, murs ferrailés, etc.). Si tel est le cas, prévoir une antenne déportée.
	Télécommande non mémorisée	Mémoriser la télécommande (voir page 28).
Le voyant  du boîtier de commande est éteint	Moteurs mal câblés	Vérifier le câblage des moteurs (voir page 18).
	L'électronique est en veille	Appuyer 2 s sur le bouton  pour réveiller l'électronique.
Le voyant  du boîtier de commande est éteint	Électronique de commande non alimentée	<ul style="list-style-type: none"> - Vérifier l'alimentation secteur. - Vérifier le câble d'alimentation.
Le voyant  du boîtier de commande clignote :		
1 clignotement	Fonctionnement sur batterie de secours	Vérifier l'alimentation secteur.
2 clignotements	Moteur en attente d'auto-apprentissage	Lancer l'auto-apprentissage de la course du portail (voir page 20).
3 clignotements	Cellules photoélectriques en défaut	<ul style="list-style-type: none"> - Vérifier qu'il n'y a pas d'obstacle entre les cellules. - Vérifier l'alignement des cellules. - Vérifier le câblage des cellules (voir page 22). - Si les cellules sont volontairement débranchées, réaliser la procédure «Désactiver la fermeture automatique» page 26.
4 clignotements	Commande permanente sur "START" du boîtier électronique (bornes 5-6)	Vérifier les accessoires branchés sur "START" du boîtier de commande.
5 clignotements	Sécurité thermique de l'électronique enclenchée	Laisser l'électronique refroidir jusqu'à ce que le voyant  se rallume fixe.
6 clignotements	Court-circuit sur "BUS" du boîtier électronique (bornes 3-4)	Vérifier les accessoires branchés sur "BUS" du boîtier électronique.
	Court-circuit sur "24 V" du boîtier électronique (bornes 7-9)	Vérifier l'accessoire branché sur "24 V" du boîtier électronique.
	Court-circuit "feu clignotant" du boîtier électronique (bornes 8-9)	Vérifier le câblage du feu clignotant (voir page 22).
	Court-circuit moteur	Vérifier le câblage des moteurs (voir page 18).
7 clignotements	Défaut électronique	Contactez l'assistance Somfy.
Le portail se réouvre en fin de mouvement de fermeture		Desserrer les pattes des vantaux et les décaler légèrement vers le centre du portail.

FR 7 CARACTÉRISTIQUES TECHNIQUES

Alimentation	230 V-50Hz / 24V (en solaire)
Type de moteur	24 V
Puissance du moteur	120 W
Puissance maxi consommée (avec éclairage de zone)	600 W
Consommation en veille	3 W (sans accessoires)
Fréquence maximum de manoeuvres par jour	20 cycles / jour 10 cycles / jour en solaire
Temps d'ouverture	20 s minimum à 90°
Détection d'obstacle automatique	Conforme à la norme EN 12 453
Température de fonctionnement	-20°C à +60°C
Protection thermique	Oui
Indice de protection	IP 44
Récepteur radio intégré	Oui
Télécommandes : - Fréquence radio - Portée en champ d'usage - Quantité mémorisable	433,42 MHz, < 10mW ~ 30 m 16
Connections possibles : - Sortie pour feu clignotant - Sortie éclairage - Sortie alimentation accessoires - Entrée pour batterie de secours - Entrée pour cellules photo-électriques - Entrée de commande de type contact sec	Clignotante, 24 V, 10 W maximum 500 W maxi en 230 V (halogène ou incandescence uniquement) 24 Vdc / 15 W maxi Oui Oui Oui (ne fonctionne pas si alimentation batterie ou solaire)

Contents

Safety instructions	2	3 Wiring the accessories	22
- Important information	2	3.1 Photoelectric cells	22
- Condition of the gate to be motorised	2	3.2 Flashing light	22
- Electrical installation	2	3.3 Battery (optional)	22
- Cable feed	3	3.4 Offset antenna (optional)	23
- Safety instructions relating to installation of the motorisation	3	3.5 Video entry phone (optional)	23
- Safety instructions relating to operation	3	3.6 Key lock (optional)	23
- Safety instructions relating to maintenance	4	3.7 Area lighting (optional)	23
- About the batteries	4	3.8 Solar power (option)	23
- Recycling and disposal	4	4 Advanced parameter settings	24
- Regulations	4	4.1 Pedestrian opening	24
- Risk prevention	4	- Pedestrian opening operation	24
		- Activating the pedestrian opening	24
Product description	6	- Deactivating the pedestrian opening	24
- Contents of the pack	6	4.2 Automatic closing	25
- Product description	7	- Automatic closure operation	25
- Space requirements	7	- Activating automatic closing	25
- Field of application	7	- Deactivating automatic closing	26
- General view of the installation	8	5 Programming the remote controls	27
- Presentation of the control electronics	9	5.1 Description of the remote controls	27
		- Possibilities for programming the 2-button remote control	27
Prerequisites for installation	9	- Possibilities for programming the 4-button remote control	27
- Pre-installation checks	9	- Using a 3-button remote control	27
- Electrical pre-equipment	10	5.2 Adding a remote control	28
- Cables required	10	- 2- or 4-button remote control	28
- Tools required for installation (not provided)	11	- 3-button remote control	28
- Hardware required for installation (not provided)	11	5.3 Deleting a remote control	28
1 Installation	12	6 Troubleshooting guide	29
1.1 Measuring the dimensions	12	6.1 Assistance	29
1.2 Fastening the pillar brackets	13	6.2 Replacing the remote control battery	29
- Marking the AM and AH axes	13	6.3 Clearing the settings	30
- Drilling the pillars	13	6.4 Unlocking/locking the motors	30
- Securing the pillar mounting bracket	14	6.5 Diagnostics	31
- Fitting the cylinder onto the mounting bracket	14	7 Technical data	32
1.3 Securing the motors to the gate leaves	14		
1.4 Installing the control unit	16		
- Position of the control unit	16		
- Installing the sealing strip	16		
- Checking the position of the antenna	16		
- Securing the control unit	16		
1.5 Connecting the motors	18		
1.6 Connecting to the power supply	18		
2 Commissioning and standard use	19		
2.1 Switching the installation on	19		
2.2 Adjusting the opening stop	19		
2.3 Gate travel auto-programming	20		
2.4 Closing the control unit	21		
2.5 Standby/Reactivating the control electronics	21		
2.6 Fully opening and closing the gate	21		
2.7 Obstacle detection	21		
2.8 User training	21		

► Safety instructions

 This symbol indicates a danger, the different degrees of which are described below.

DANGER

Indicates a danger which may result in immediate death or serious injury.

WARNING

Indicates a danger which may result in death or serious injury.

PRECAUTION

Indicates a danger which may result in minor or moderate injury.

CAUTION

Indicates a danger which may result in damage to or destruction of the product.

WARNING

CAUTION - Important safety instructions
For reasons of personal safety, it is important to follow all the instructions, as incorrect installation can lead to serious injury. Retain these instructions. The installer must train all users to ensure the motorisation is used in complete safety, in accordance with the operating manual. The instructions must be given to the end user.

► Important information

This product is a motorisation for a hinged gate on a residential property as defined in standard EN 60335-2-103, with which it is compliant. The main purpose of these instructions is to satisfy the requirements of the aforementioned standards and to ensure the safety of equipment and persons.

WARNING

Any use of this product outside the field of application described in this manual is prohibited (see "Field of application" paragraph in the manual). The use of any accessory or any component not recommended by Somfy is prohibited, on safety grounds.

Somfy cannot be held liable for any damage resulting from failure to follow the instructions in this manual.

If in any doubt when installing the motorisation or to obtain additional information, consult the website www.somfy.com. The instructions may be modified if and when there is a change to the standards or to the motorisation.

► Condition of the gate to be motorised

Before installing the motorisation, check that:

- the gate is in good mechanical condition.
- the gate is stable regardless of its position.
- the structures supporting the gate allow the motorisation to be fixed securely. Strengthen these if necessary.
- the gate can be correctly opened and closed manually using a force of less than 150 N.
- the temperature range inscribed on the motorisation is suitable for the location.

CAUTION

Do not spray water onto the motorisation.
Do not install the motorisation in an explosive environment.

WARNING

Ensure that any danger zones (crushing, cutting, trapping) between the driven part and the surrounding fixed elements caused by the opening movement of the driven part are avoided or indicated on the installation (see "Risk prevention").

Permanently affix the crushing warning labels near to any fixed control devices, and so that they are clearly visible to the user.

► Electrical installation

DANGER

The installation of the power supply must comply with the standards in force in the country in which the motorisation is installed, and must be carried out by qualified personnel.

DANGER

The electric line must be exclusively reserved for the motorisation and equipped with protection, comprising:

- a 10 A fuse or breaker,
- a differential type device (30 mA).

An all-pole power supply cut-off device must be provided. The switches provided to ensure a cut-out of all poles on fixed appliances must be connected to the power supply terminals and there must be a separation between the contacts on all poles to ensure complete disconnection in conditions where category III high impulse voltage is present. Low-voltage cables subject to inclement weather must be at least of type H07RN-F. It is recommended that you fit a lightning conductor (mandatory maximum residual voltage of 2 kV).

► Cable feed

DANGER

Underground cables must be equipped with a protective sheath with a sufficient diameter to contain the motor cable and the accessories cables. For overground cables, use a cable grommet that will withstand the weight of vehicles (ref. 2400484).

► Safety instructions relating to installation of the motorisation

WARNING

Take off any jewellery (bracelet, chain, etc.) during installation.

For manoeuvring, drilling and welding operations, wear appropriate protection (special glasses, gloves, ear protection, etc.).

DANGER

Do not connect the motorisation to a power supply (mains, battery or solar) until installation is complete.

WARNING

Modifying one of the elements provided in this kit or using an additional element not recommended in this manual is strictly prohibited.

Monitor the gate as it moves and keep people away from it until installation is complete.

Do not use adhesive to secure the motorisation.

WARNING

Manual unlocking may result in uncontrolled movement of the gate. Permanently affix the label concerning the manual unlocking device near its mobile component.

WARNING

Install any fixed control device at a height of at least 1.5 m and within sight of the gate, but away from moving parts.

After installation, ensure that:

- the mechanism is correctly adjusted.
- the manual unlocking device is operating correctly.
- the motorisation changes direction when the gate encounters an object measuring 50 mm positioned halfway up the leaf.

WARNING

For operation in automatic mode or remote control, photoelectric cells must be installed. In automatic mode, the motorisation operates in at least one direction with no intentional activation by the user.

For operation in automatic mode or if the gate faces a public road, installation of a flashing light may be required in accordance with the regulations in the country in which the motorisation is commissioned.

► Safety instructions relating to operation

WARNING

This motorisation may be used by children aged 8 and over and by persons whose physical, sensory or mental capacity is impaired, or persons with little experience or knowledge, as long as they are under supervision or have received instructions on safe use of the motorisation and fully understand the associated risks. Do not allow children to play with the gate control devices. Keep remote controls out of the reach of children. Children must not be allowed to clean or maintain the unit.

The sound pressure level of the motorisation is less than or equal to 70 dB(A). The noise emitted by the structure to which the motorisation will be connected is not taken into account.

WARNING

Any potential user must be trained by the installer in using the motorisation, applying all the recommendations in this manual. It is essential to ensure that no untrained persons are able to put the door into motion.

The user must monitor the gate each time it moves and keep people away from it until it is completely open or closed.

Do not deliberately prevent the gate from moving.

WARNING

If not operating correctly, switch off the power supply and unlock the motorisation immediately to gain access to it and contact Somfy assistance.

Do not try to open the gate manually if the motorisation has not been unlocked. Ensure that no natural obstacles (branch, stone, tall grasses, etc.) are able to obstruct the movement of the gate.

► Safety instructions relating to maintenance

! DANGER

The motorisation must be disconnected from any power supply during cleaning and maintenance and when parts are replaced.

! WARNING

Every month, check:

- the installation, looking for any signs of wear or damage to the cables and assembly.
- that the motorisation changes direction when the gate encounters an object measuring 50 mm positioned halfway up the leaf

Do not use the motorisation if it needs repairing or adjusting. Gates in poor condition must be repaired, reinforced or even replaced.
Use only original parts for any maintenance or repair work.
Any technical, electronic or mechanical modification to the motorisation must be made with the approval of Somfy assistance.

If the installation is equipped with photoelectric cells and/or a flashing light, regularly clean the photoelectric cell optical units and the flashing light.

► About the batteries

! DANGER

Do not leave batteries of any kind within reach of children. Keep them somewhere children cannot access. There is a risk that they could be swallowed by children or pets. Danger of death! If this does occur, seek medical advice immediately or go to hospital.
Ensure that the batteries are not short-circuited, thrown in the fire or recharged. There is a risk of explosion.

► Recycling and disposal

If installed, the battery must be removed from the motorisation before the latter is disposed of.

 Do not dispose of used remote control or other batteries with household waste. They must be taken to the relevant recycling points.

 Do not dispose of the motorisation with household waste at the end of its life. Return the motorisation to its distributor or use your local authority's special waste collection services.

► Regulations

CE Somfy declares that the product described in these instructions, when used in accordance with the instructions, complies with the essential requirements of the applicable European Directives, and in particular Machinery Directive 2006/42/EC and Radio Equipment Directive 2014/53/EU.

The full text of the EC declaration of conformity is available on the following website: www.somfy.com/ce. Antoine CREZE, Head of Regulations, Cluses

► Risk prevention

Identification of risk zones

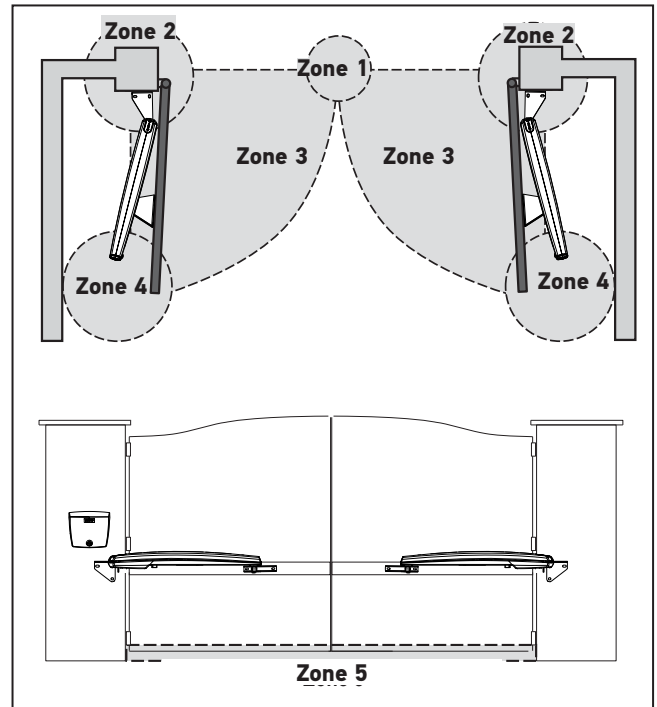

Measures to be taken to counter risks

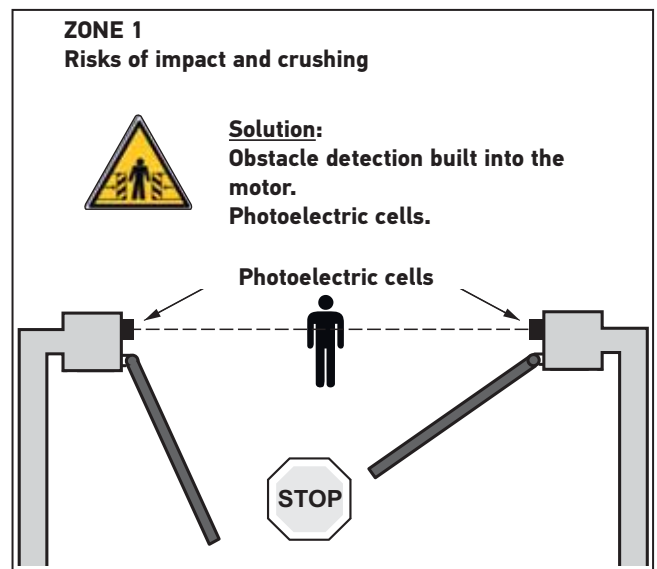

ZONE 2
Risks of crushing and cutting of hands

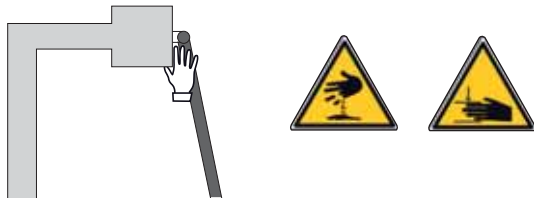

Solution:
If there a cutting risk zone on the installation:
- leave a distance of at least 10 cm between the leaf and the pillar/wall.
- cut off the corner of the pillar without weakening it.

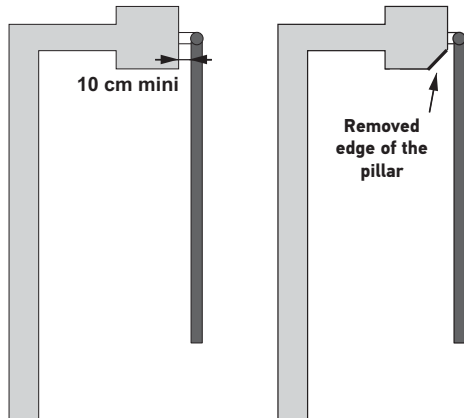

ZONE 4
Risk of trapping and crushing



Solution:
Obstacle detection built into the motor.
If there is an area between the gate leaves and the surrounding fixed elements where someone could get trapped, you must leave a minimum distance of 50 cm between the gate leaves and the fixed sections.

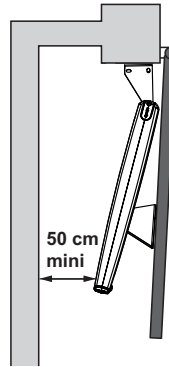

ZONE 3
Risk of impact
Solution:
Obstacle detection built into the motor.

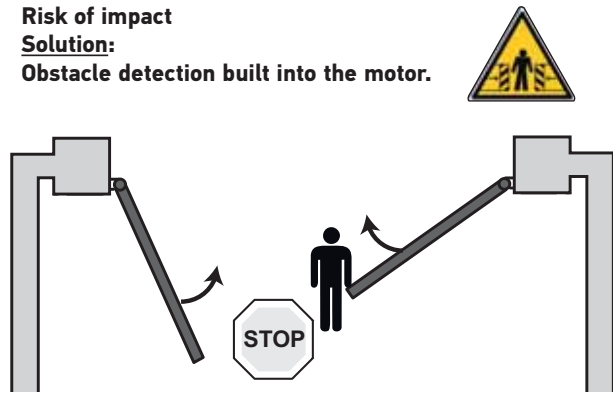

ZONE 5
Risk of feet being trapped



Solution:
If there is an area where feet could be trapped between the bottom of the gate leaves and the ground, you must leave a distance between the bottom of the gate leaves and the ground of a minimum of 12 cm or a maximum of 5 mm.

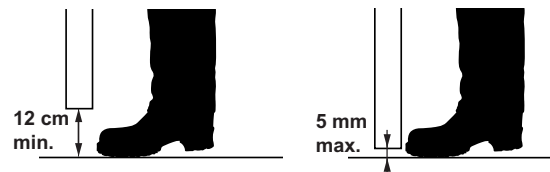

Product description

Contents of the pack

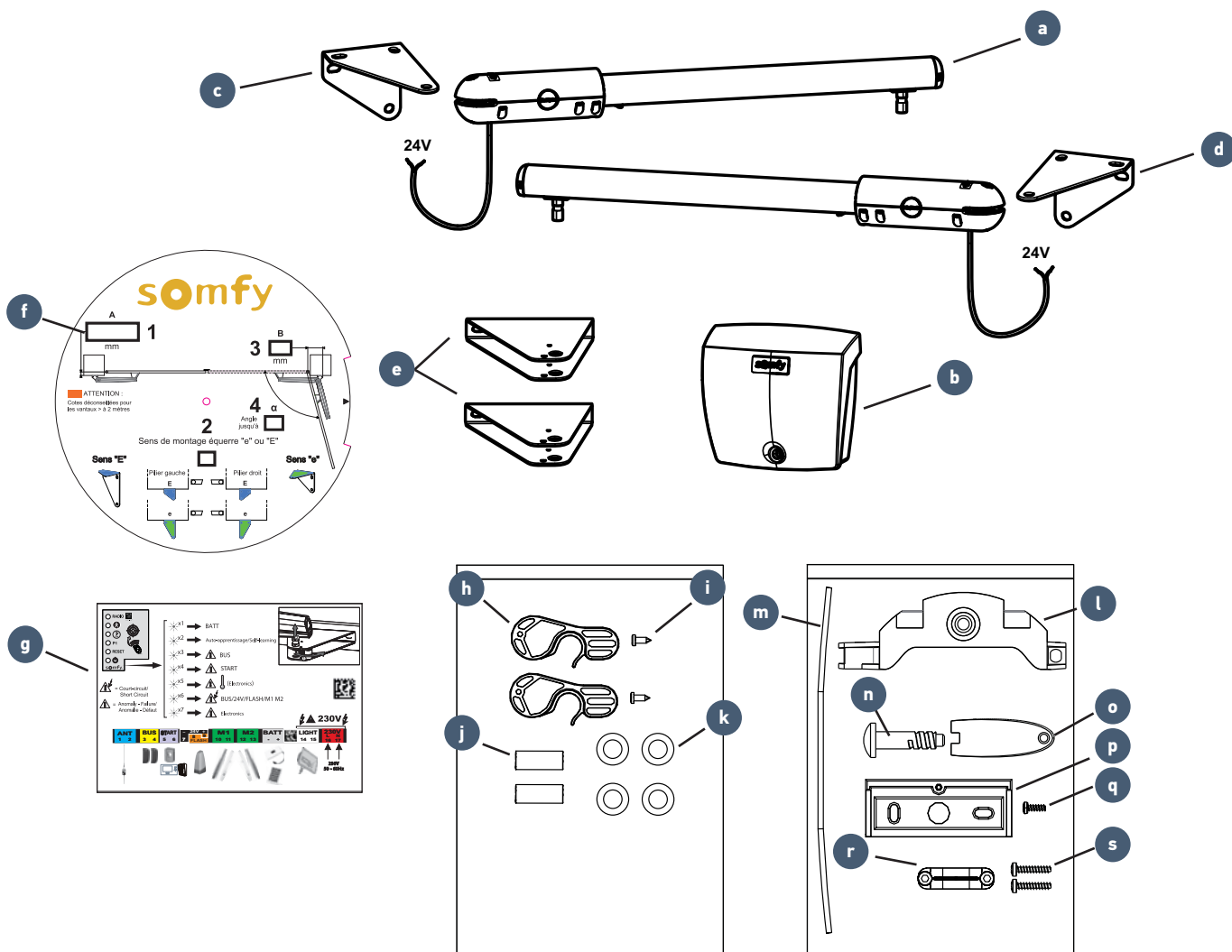

No.	Designation	Quantity
a	24V cylinder	x2
b	Control unit	x1
c	Wall/pillar left-hand mounting bracket	x1
d	Wall/pillar right-hand mounting bracket	x1
e	Gate leaf mounting bracket	x2
f	Disc for reading dimensions	x1
g	Summary label	x1
Cylinder accessories pouch		
h	Unlocking mechanism	x2
i	Unlocking mechanism screw	x2
j	Pin for securing the cylinder to the wall/pillar bracket	x2
k	M8x22 flat washer	x4

No.	Designation	Quantity
Control unit accessories pouch		
l	Battery bracket	x1
m	Sealing strip	x1
n	Unit cover screw	x1
o	Unit cover unlocking key	x1
p	Wall mounting bracket	x1
q	Screw for securing the unit to the bracket	x1
r	Cable clamp	x1
s	Cable clamp bolt	x2

► Product description

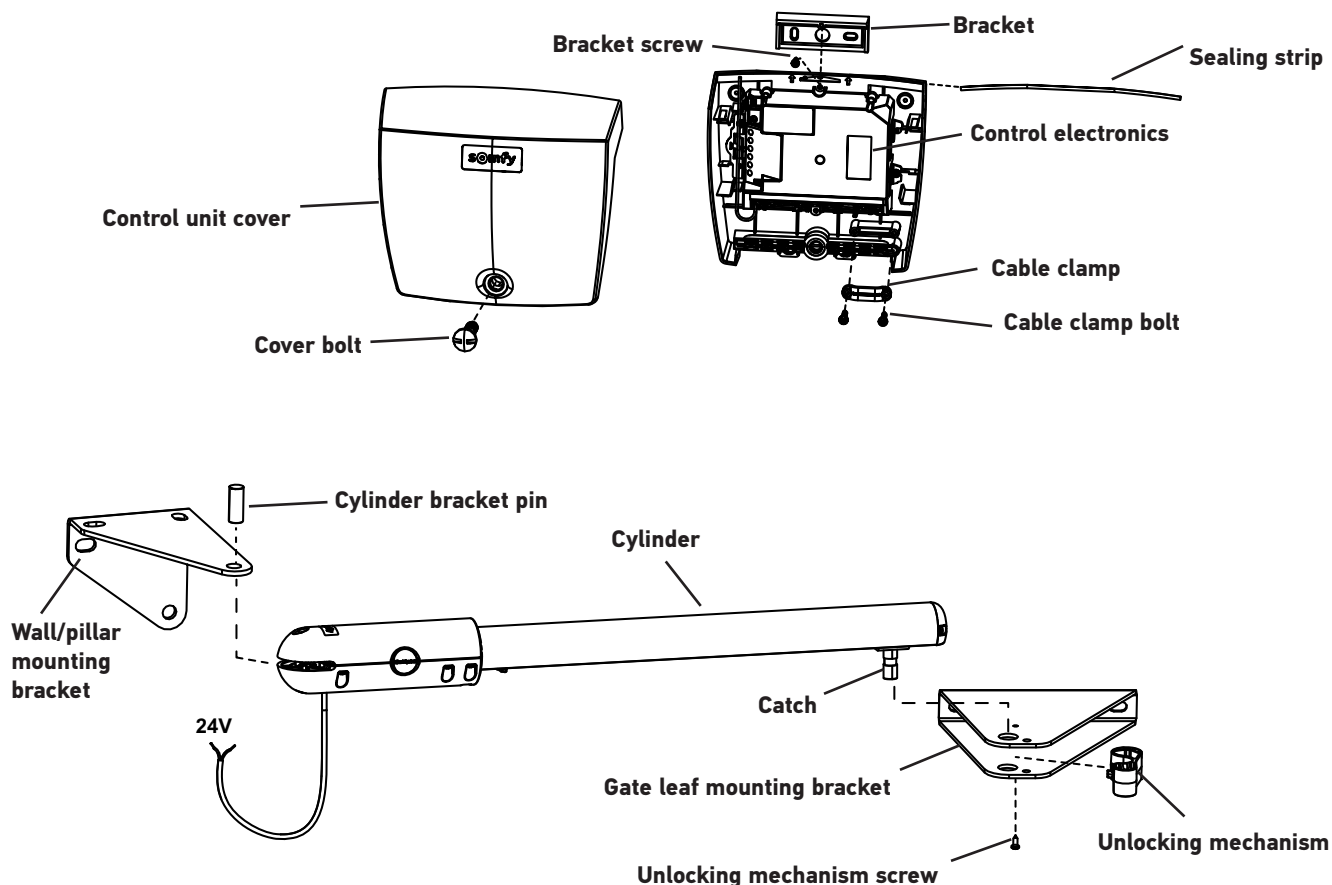

► Space requirements

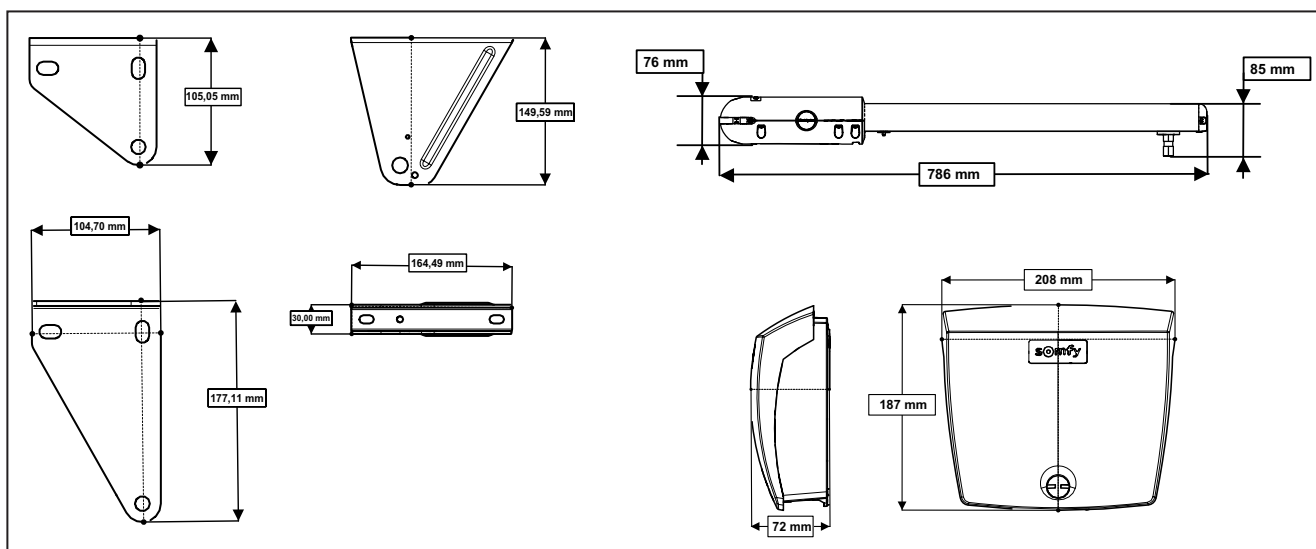

► Field of application

This automatic control system has been designed to motorise residential double door gates for a detached house.





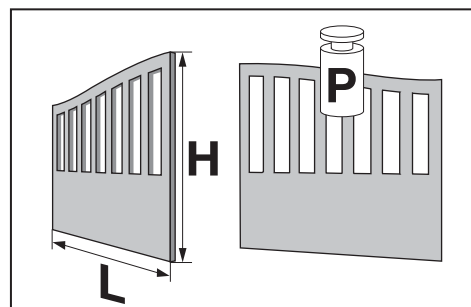

Dimensions and weight of the gate leaves

Max. weight per leaf (P)	200 kg
Max height per gate leaf (H)	2 m
Min./Max. width per leaf (L)	1.25/2 m

The type of gate (solid/open-worked) and the weather conditions (presence of strong winds), may reduce these maximum values (see table below).



Dimensions and weight of gate leaves which can be motorised, based on the wind strength

Wind strength	Effect	Product	SGS LINE
≥ 80 Km/h	The wind is too strong to walk against	 Min./Max. width. Max weight.	1.25/1.5 m 200 kg
< 80 Km/h > 40 Km/h	The branches of the trees are moving	 Min./Max. width. Max weight.	1.25/2 m 200 kg
		 Min./Max. width. Max weight.	1.25/1.5 m 200 kg
≤ 40 Km/h	Sand is flying	 Min./Max. width. Max weight.	1.25/2 m 200 kg
		 Min./Max. width. Max weight.	
		 Min./Max. width. Max weight.	



Openworked gate



Semi-openworked gate



Solid gate

► **General view of the installation**

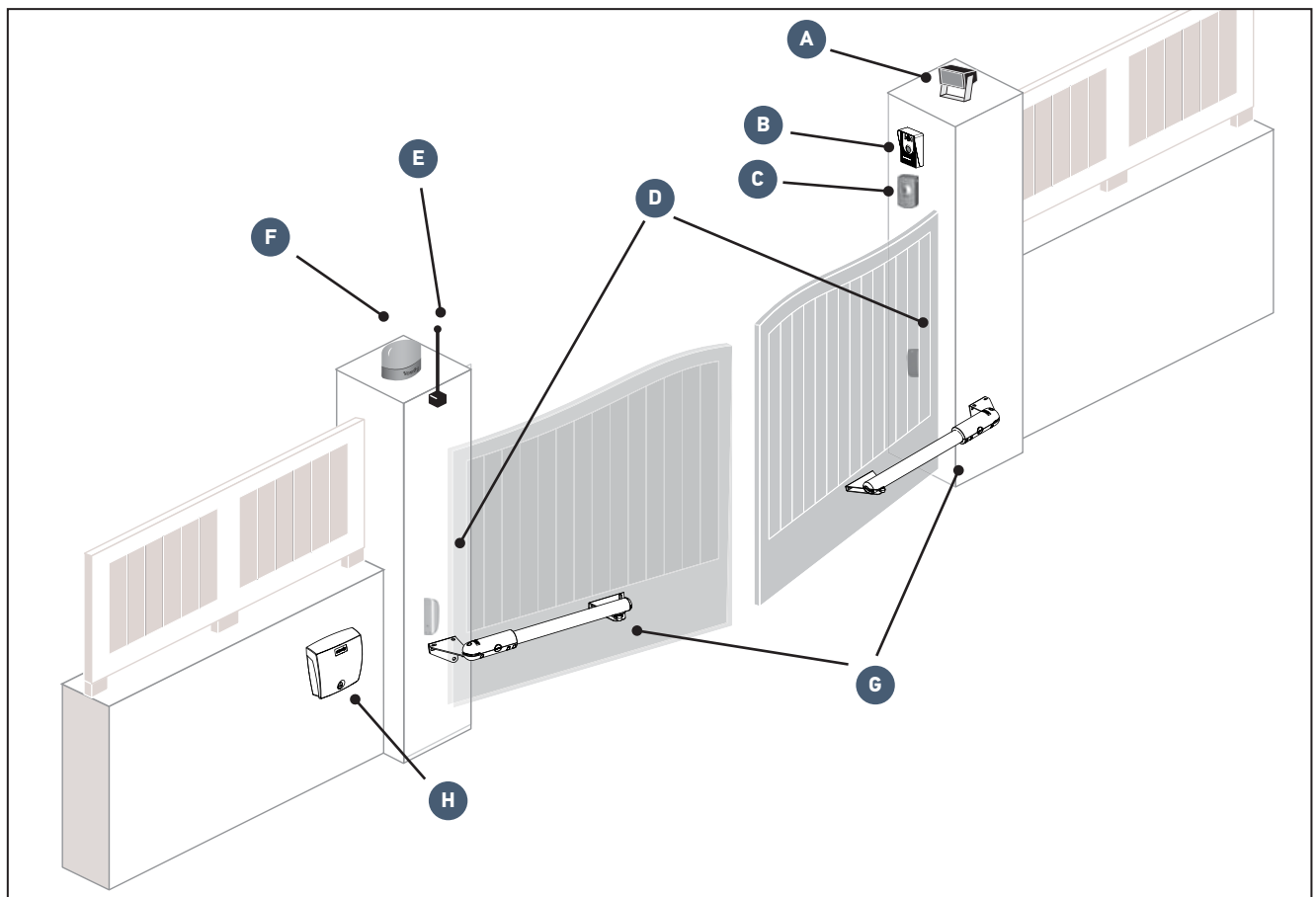

Mark	Description
A	Area lighting*
B	Video entry phone*
C	Key lock*
D	Photoelectric cells

Mark	Description
E	Offset antenna*
F	Flashing light
G	Motors
H	Control unit

*optional accessories

► Presentation of the control electronics

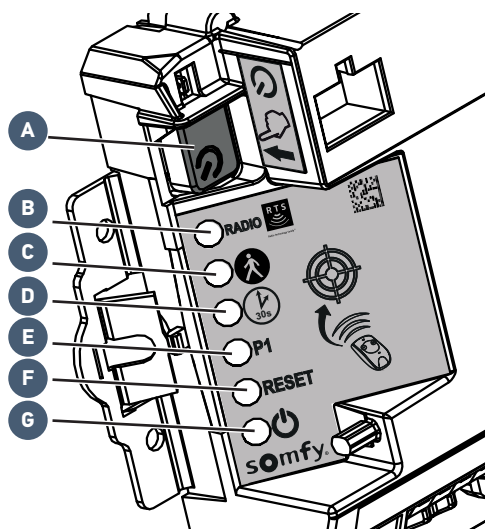

No.	Description	Function	
A	Button	Reactivation of the control electronics	
B	RADIO indicator light	Lights up each time the control electronics receive a radio command	
C	Indicator light	Lights up during activation/deactivation of the pedestrian opening	
D	Indicator light	On	automatic closure of the gate is activated
		Off	automatic closure of the gate is not activated
		Flashing	the "automatic closing" parameter is selected
E	Indicator light P1	Not used	
F	RESET indicator light	On	the settings alone or the settings and the radio control points are deleted
		Flashing	the settings and radio control points deletion function is selected
G	Indicator light	On	the motorisation functions correctly - the control electronics are reactivated
		Off	the motorisation functions correctly - the control electronics are in standby
		Flashing	see "Diagnostics" page 31

► Prerequisites for installation

► Pre-installation checks

Gate

Your gate is in good condition: it opens and closes normally with ease. It remains horizontal throughout its travel. It opens inwards towards your property.

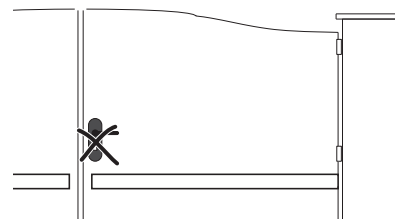
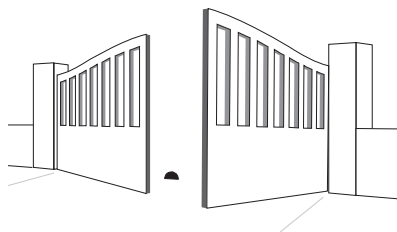
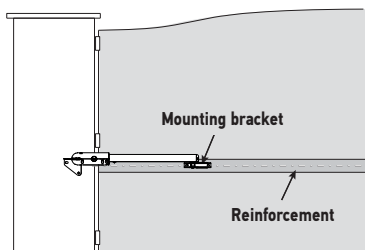

Reinforcements

The motors must be secured to the horizontal reinforcements of the gate leaves, which should ideally be positioned 1/3 up the gate.

If there are no reinforcements, use metal reinforcement plates approximately 4 mm thick.

Closing end stops on the ground

The gate's closing travel must be defined by end stops firmly fixed in the ground. The opening stops are integrated in the motor (see "Adjusting the opening stop" page 19).

Mechanical lock

If the gate is equipped with a mechanical lock, it must be removed.

Pillars

The pillars must have a robust structure and be at least 21 cm wide. If they do not, improvements may have to be made to your pillar to guarantee correct installation and to ensure that the bracket stays in place.

It is not recommended to mount the bracket level with the pillar: risk of spalling.

► Electrical pre-equipment

Cables required

- Power supply: 3 x 1.5 mm² cable or 3 x 2.5 mm² for outdoor use (type H07RN-F as minimum requirement).
- Connection between the motors: 2 x 1 mm² cable; fit an IP 55 junction box to protect the connection between the cable leaving the motor and the extension which goes to the control unit.
- Linking of cells: 2 x 0.75 mm² cable;.



Provision must be made for the power supply cable to be fed through in accordance with the electrical standards in force in the country of use.

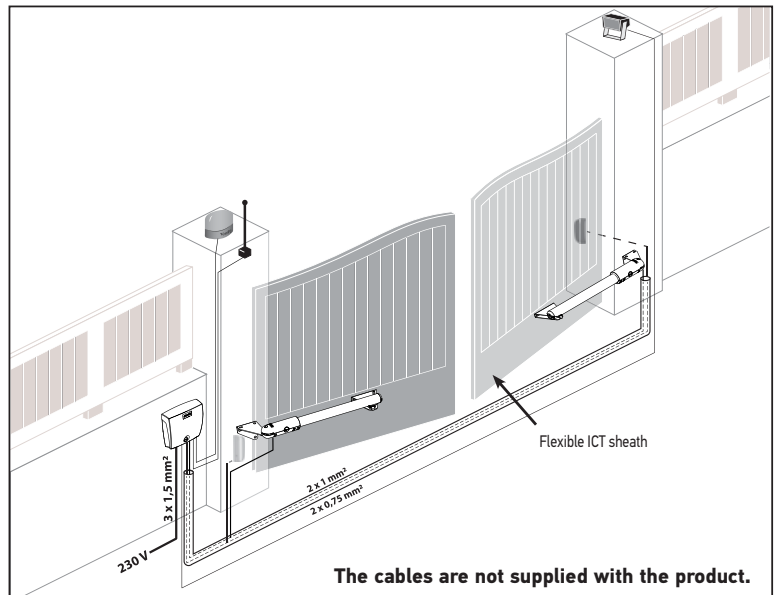
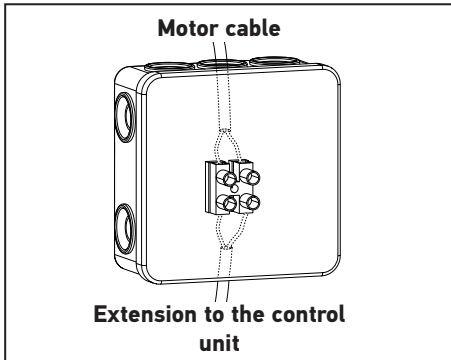

Cable feed

- Underground cables must be equipped with a protective sheath with a sufficient diameter to contain all the cables.
- Fit a 230 V electrical input as close as possible to the control unit.

► Cables required



If a cable conduit cannot be made, use a cable grommet which will withstand the weight of vehicles (ref. 2400484).



Details of the wiring are given in the section entitled "Wiring the accessories" page 22.

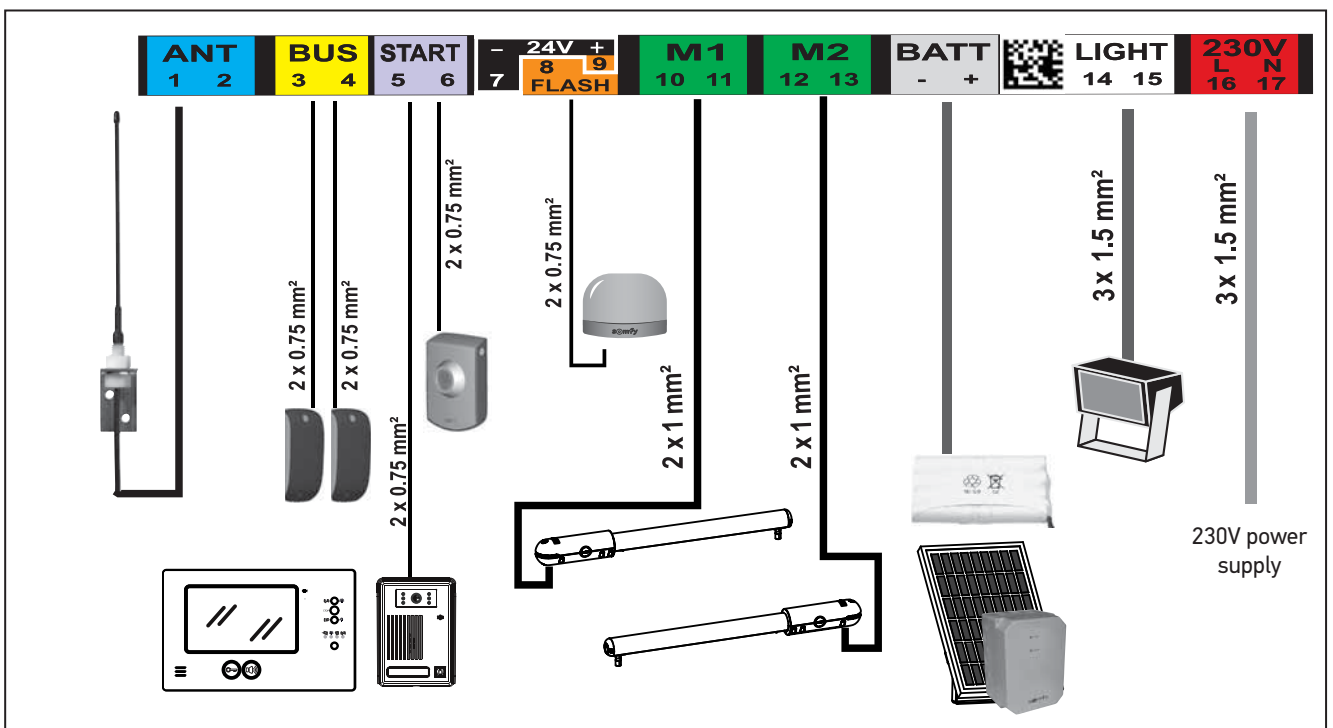

► Tools required for installation (not provided)

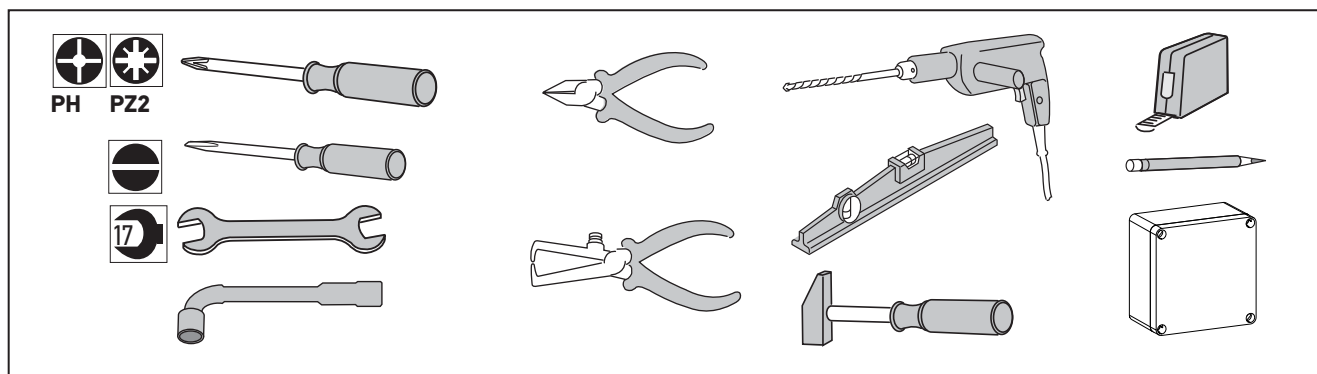

► Hardware required for installation (not provided)

This information is provided for information purposes.

For securing the...		Quantity
BRACKETS TO THE PILLARS/WALLS		
	Hardware adapted to the material of the pillar/wall (screws, studs, chemical seals, etc.): - diameter: 8 to 10 mm - hex head	6
	Washers: - internal diameter: 8 to 10 mm - external diameter: 16 to 20 mm Nuts: - diameter: 17 mm	6
BRACKETS TO THE GATE LEAVES		
	Hardware adapted to the material of the gate leaf reinforcement: - diameter: 8 mm - length adapted to the thickness of the gate leaf reinforcement	6
	Washers supplied - internal diameter: 8 mm - external diameter: 22 mm	6
CONTROL UNIT		
	Hardware adapted to the material of the pillar/wall - screw diameter: 3.5 to 4.5 mm - raised or flat-head screws - Type "S" rawl plug for concrete: S5, S6 or S8	4

1.1 Measuring the dimensions

Take the dimensions using disc (f) to determine the position of the motors on the pillars.

Note: For these measurements, the gate leaves and their hinge pins are assumed to be on the same axis.

N.B.: You must leave a minimum distance of 50 cm between the gate leaves and the fixed sections (see "Risk prevention" page 4).

1 Measure dimension A.

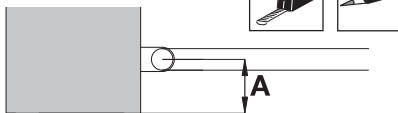

Transfer the measured dimension A on the disc.

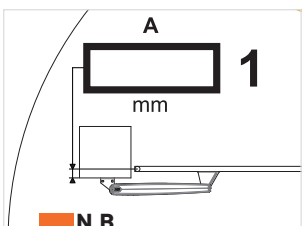

N.B
Dimensions not recommended for gate leaves > 2 metres

3 Determine dimension B

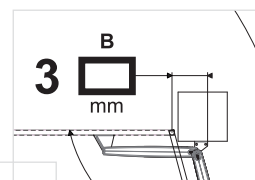

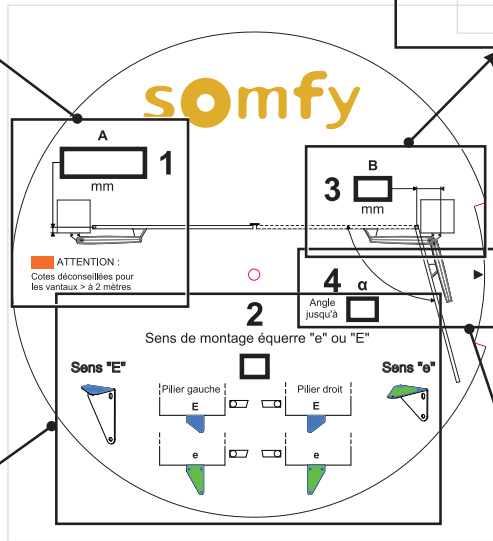

ATTENTION :
Cotes déconseillées pour les vantaux > à 2 mètres

Angle jusqu'à α

Sens de montage équerre "e" ou "E"

Sens "E" Piller gauche Piller droit Sens "e"

2 The direction of fitting (e or E) of the cylinder mounting bracket is stated.

Bracket direction of fitting "e" or "E"

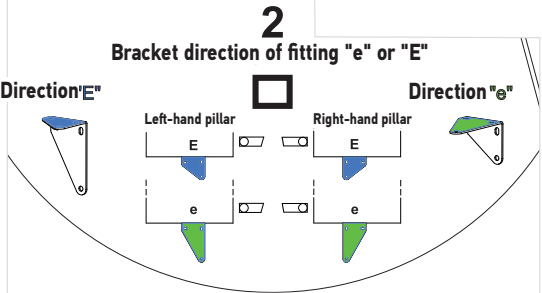

Direction "E" **Direction "e"**

Left-hand pillar Right-hand pillar

Take care to ensure the bracket is fitted the right way up.



Correct orientation



Incorrect orientation

4 The maximum opening angle α is indicated.

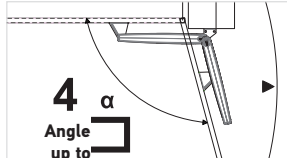

Angle up to α

! Observe the maximum opening angle given by the disc.



Recommended: dimension A is negative

If dimension A is negative, the gate leaf hinge is located in front of the pillar. We recommend that you add a shim so that the cylinder mounting bracket is aligned with the gate leaf hinge and A is 0 cm.

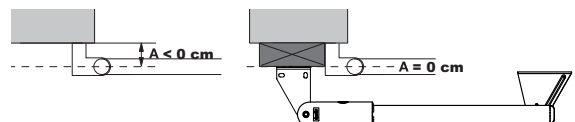

1.2 Mounting the pillar brackets

▶ Marking the AM and AH axes

1. Transfer dimension B onto the pillar using the hinge axis and mark a vertical axis AM on the pillar.
2. Mark the horizontal axis AH on the pillar, halfway up the reinforcement.



Check before proceeding to the next step
Have you marked the AM and AH axes?

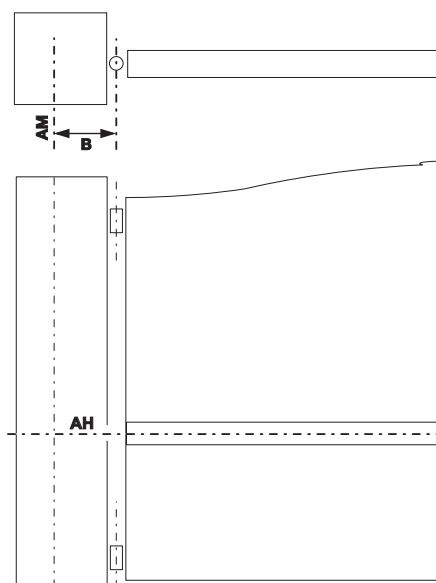

▶ Drilling the pillars

1

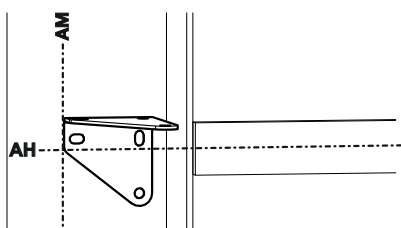

Align the markings made on the bracket with the AH axis and align the edge of the bracket with the AM axis.
Note: The markers marked on the bracket are underneath the oblong holes.



Position the bracket in direction e or E defined in step 2 of measuring the dimensions (see page 12).

Left-hand pillar

Right-hand pillar

Direction E

Direction E

Direction E

Direction E

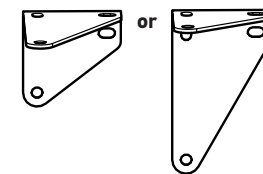
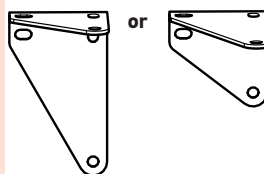

Take care to ensure the bracket is fitted the right way up.



Correct orientation

Incorrect orientation

2

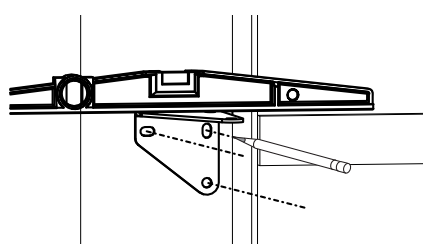

Check that the bracket is horizontal, then mark the mounting holes for the bracket.

3

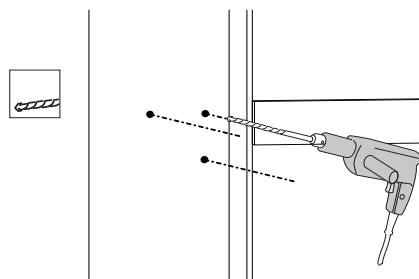

Drill 3 holes in each pillar in the locations marked (see page 11 for the drilling diameter corresponding to suitable hardware).

► Securing the pillar mounting bracket

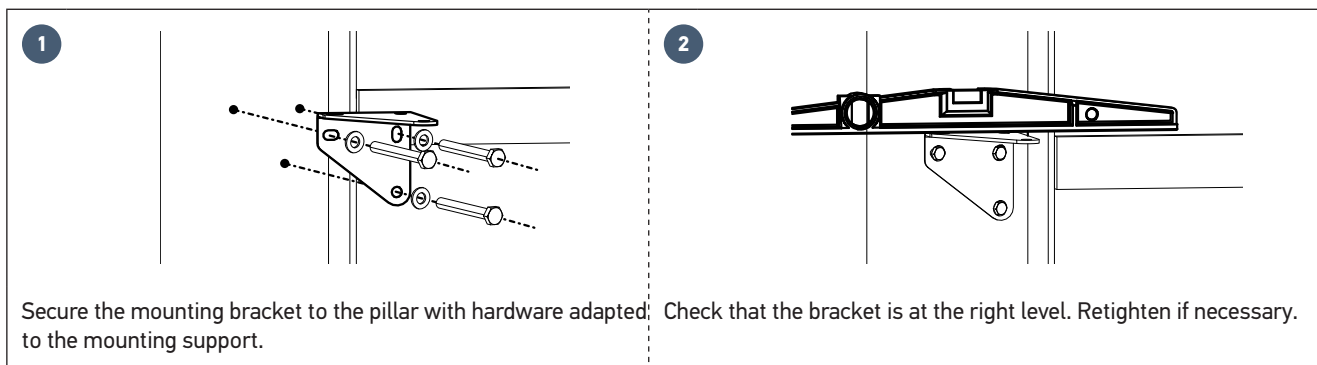

Check before proceeding to the next step

Have you checked that the brackets are perfectly horizontal on the cylinders?

► Fit the cylinder onto the mounting bracket

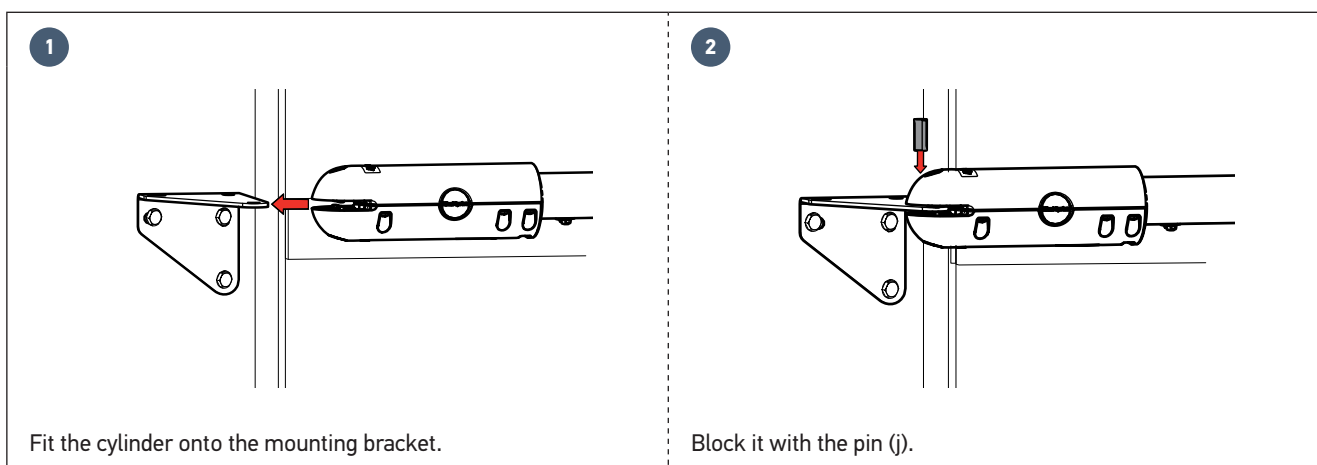





1.3 Securing the motors to the gate leaves

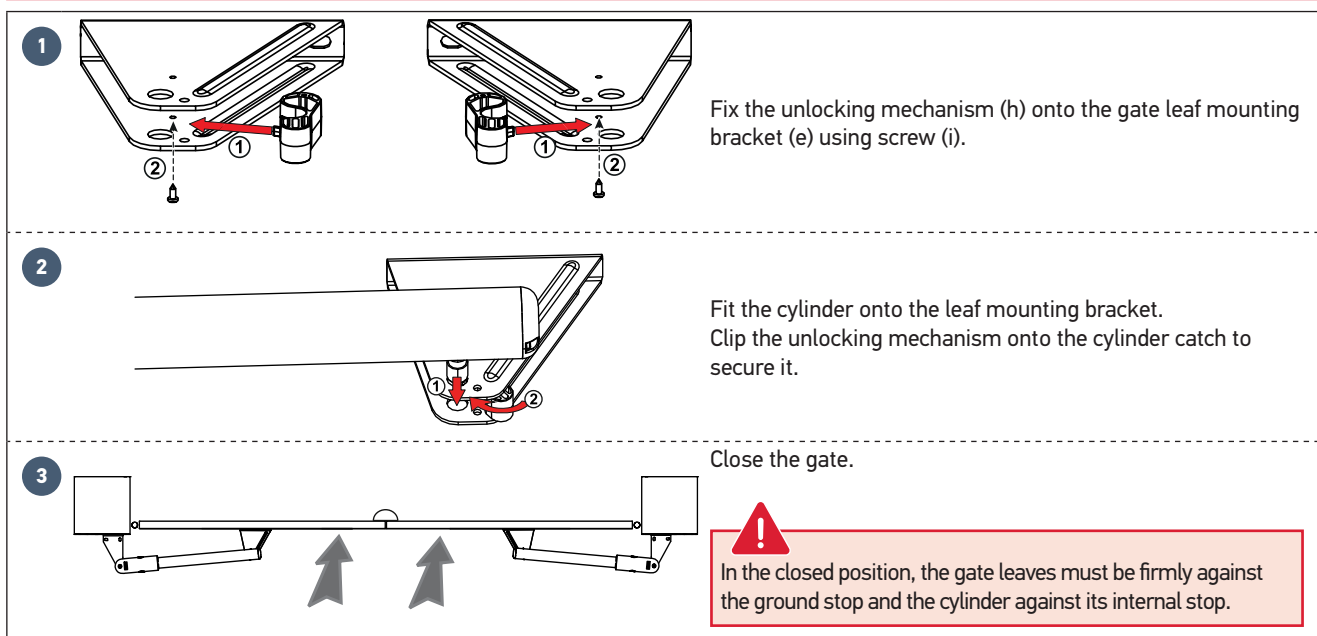

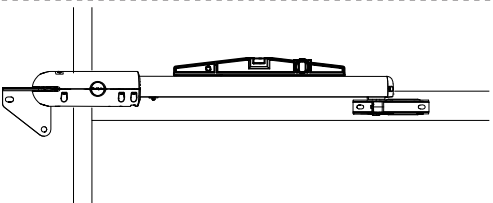
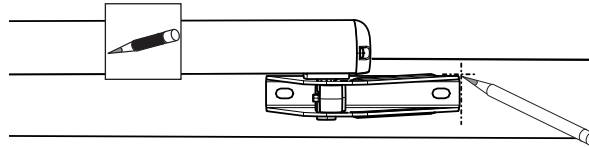
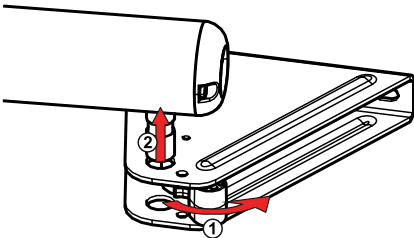
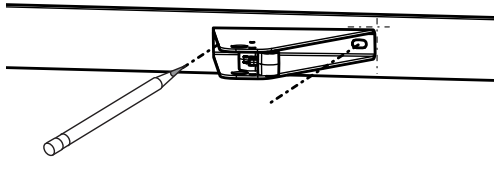
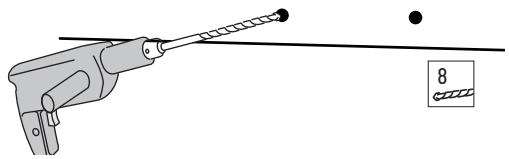
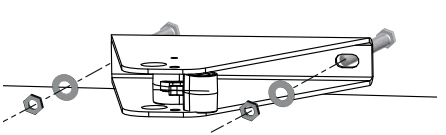
Never operate the cylinder before having finished mounting it on the gate leaf. If this happens, the internal cylinder could be incorrect and malfunctions could occur.

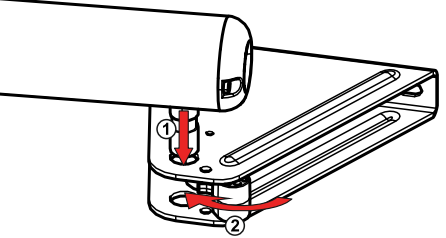

<p>4</p>		<p>Push the gate leaf mounting bracket against the gate leaf reinforcement. Check that the cylinder is level.</p>
<p>5</p>		<p>Make the markings on the sides of the gate leaf mounting bracket.</p>
<p>6</p>		<p>Unclip the unlocking mechanism, then remove the cylinder from the gate leaf mounting bracket.</p>
<p>7</p>		<p>Reposition the gate leaf mounting bracket then mark the mounting holes in the centre of the oblong holes.</p>
<p>8</p>		<p>Drill the gate leaves with a diameter of 8.</p>
<p>9</p>		<p>Secure the gate leaf mounting bracket to the two points on the gate leaves using screws (j) suited to the reinforcement material and the washers (j) supplied.</p> <div style="border: 1px solid red; padding: 5px; margin-top: 10px;"> <p> The washers (k) provided must be fitted.</p> </div>
<p>10</p>		<p>Fit the cylinder. Clip the unlocking mechanism on the catch to secure it.</p>

 **Check before proceeding to the next step**
Have you checked that the cylinders are perfectly horizontal?

1.4 Installing the control unit

► Position of the control unit

The unit will be mounted on a pillar/wall on the side where the power supply arrives.

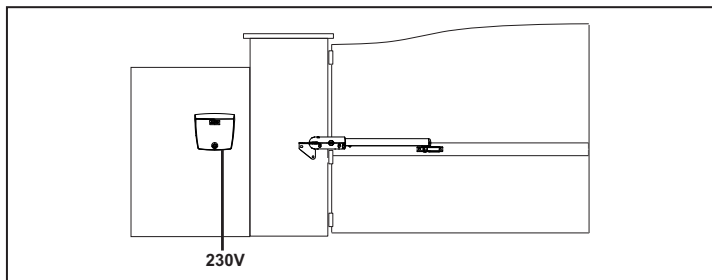

► Installing the sealing strip

Fit sealing strip (m) inside the top of the control unit.

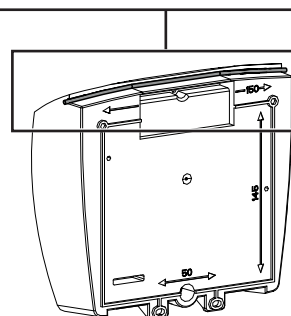
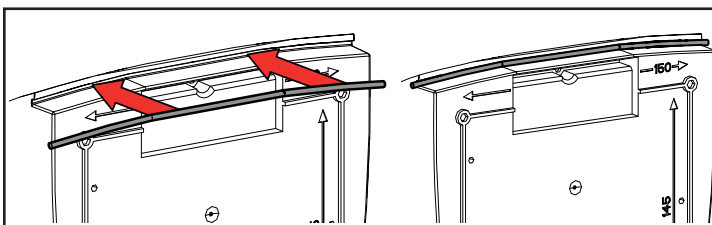

► Checking the position of the antenna

For optimum performance, it is essential that the antenna is correctly positioned.



Do not cut the antenna wire.

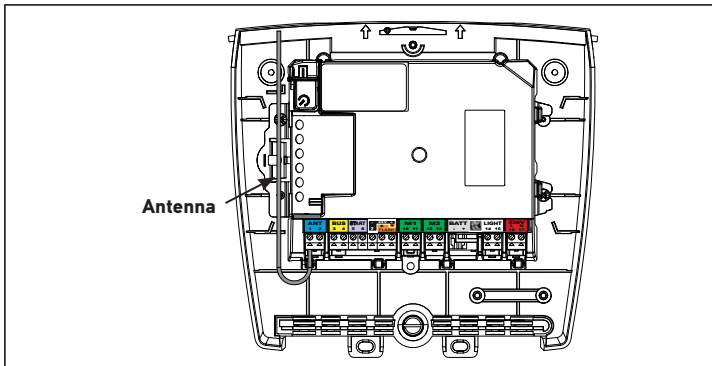

► Securing the control unit

<p>1</p>	<ul style="list-style-type: none"> • Position the unit mounting bracket (p) against the pillar/wall. • Check that it is horizontal by placing a spirit level in the intended location. • Mark the mounting points for the bracket.
<p>2</p>	<p>Remove the bracket and drill the pillar/wall. The drilling diameter is to be defined based on the type of screws used for mounting (see page 11).</p>

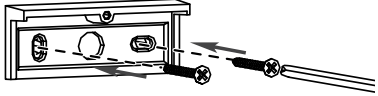
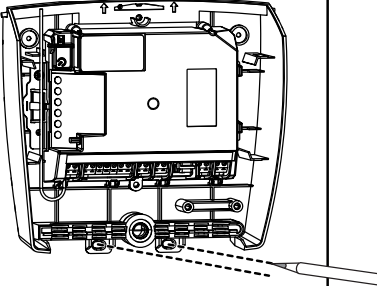
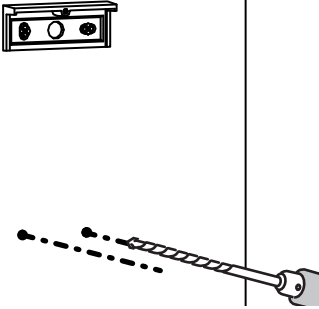
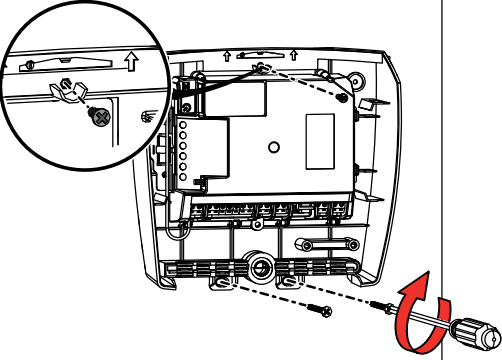
<p>3</p>		<p>Secure the bracket to the pillar/wall.</p>
<p>4</p>		<p>Position the base of the unit to mark the 2 mounting points at the bottom of the unit.</p>
<p>5</p>		<p>Remove the base of the unit then drill the pillar/wall. The drilling diameter is to be defined based on the type of screws used for mounting (see page 11).</p>
<p>6</p>		<p>Secure the base of the unit to the pillar/wall: 1 screw (q) to secure the unit to the bracket + 2 screws to secure the unit to the pillar/wall.</p>

1.5 Connecting the motors



Motor M1 activates the gate leaf which:

- opens first and closes last,
- opens for pedestrian access.

1

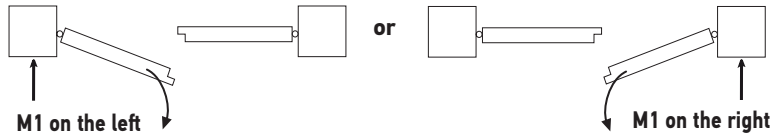

With the gate closed, identify the gate leaf that opens first.
Motor M1 activates this gate leaf.

2

Connect the motors as indicated in the table below:

Connect motor wire...		to terminal ...
M1	blue	10
	brown	11
M2	blue	12
	brown	13

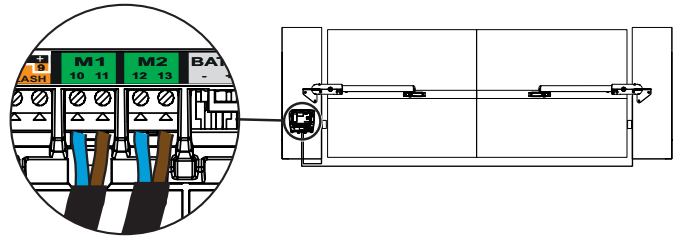

1.6 Connecting to the power supply



For your safety, these operations must be carried out with the power supply switched off.

Use a 3 1.5 x 1.5 mm² cable for outdoor use (at least H07RN-F type).

The cable clamp supplied must be used. For all low-voltage cables, ensure that they can withstand traction of 100 N.

Check that the conductors have not moved when this traction has been applied.

1

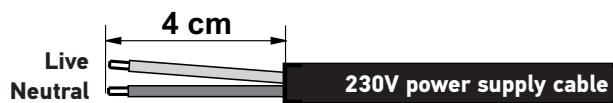

On a 3 x 1.5 mm² type cable, prepare 2 x 4 cm wires (live and neutral).

2

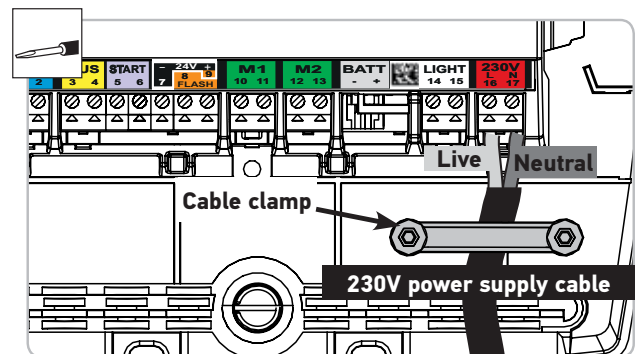

- Connect live and neutral to terminals 16 and 17 (red "230 V" label).
- Immobilise the 230 V power cable with the cable-clamp provided (r).
- Fit a terminal block on the earth wire (yellow/green) and store it in the control unit.

2.1 Switching the installation on

The  indicator light flashes (twice).

The motorisation is switched on and awaiting auto-programming.

If the  indicator light does not come on or the number of flashes is not as expected: see "Diagnostics" page 31.

2.2 Adjusting the opening stop





Opening end stop

The opening stops are integrated into the cylinder. They delimit the travel of the gate leaf when opening.

N.B.: Your installation must be equipped with closing stops secured to the ground to mark out the travel of the gate when closing.

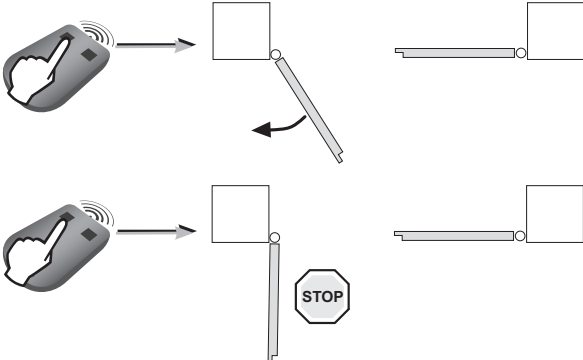
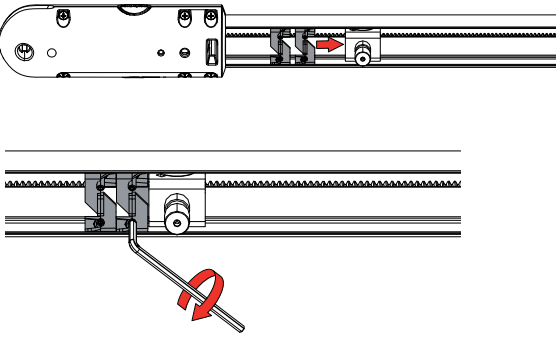
During this phase, pressing button 1 on the programmed remote control only causes the gate to open and stop (1st press = open, 2nd press = stop, 3rd press = open, 4th press = stop, etc.), you can therefore set the desired opening position in several increments. it will be possible to close the gate once the opening stops are installed.

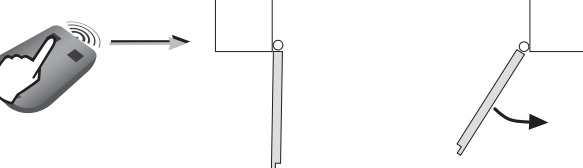
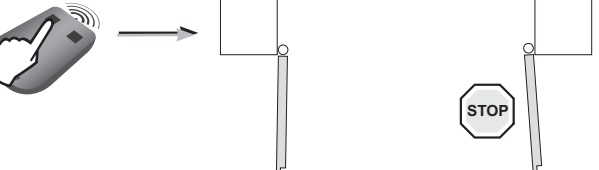
<p>1</p> 	<ul style="list-style-type: none"> • Press button 1 on the remote control. After a few seconds, the first gate leaf opens, slowly. If the gate leaf does not open, check that the motors are wired as shown on page 18. • Press button 1 on the remote control again to stop the gate leaf in the desired opening position.
<p>2</p> 	<p>Position the opening stop in contact with the cylinder knob then tighten the stops using an Allen key, diameter 3 (2 screws per stop).</p> <div style="border: 1px solid red; padding: 5px; display: inline-block;">  Perform 2 full turns of the key after contact. </div>
<p>3</p> 	<p>Press button 1 on the remote control. The second gate leaf opens.</p>
<p>4</p> 	<p>Press button 1 on the remote control again to stop the gate leaf in the desired opening position.</p>

5

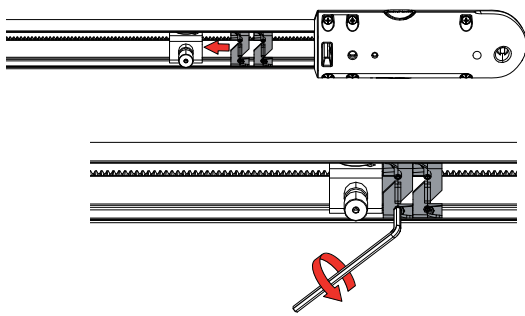

Position the opening stop in contact with the cylinder knob then tighten the stops using an Allen key, diameter 3 (2 screws per stop).

!
Perform 2 full turns of the key after contact.

6

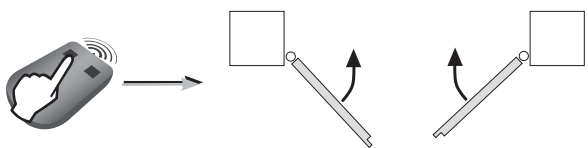

Press button 1 on the remote control to close the gate completely. The leaves close one after the other.

Check before proceeding to the next step
Have you set the position of the opening stop on each motor?

2.3 Gate travel auto-programming

Check that the installation is switched on: the  indicator light flashes (twice).

Case 1: First commissioning of your motorisation

Press button 1 on the remote control to initiate a COMPLETE opening motion of the gate.

When the gate is completely open, press button 1 on the remote control again to initiate a COMPLETE closing movement of the gate.

When the gate is completely closed, the  indicator light on the control unit should be CONTINUOUSLY LIT.

Case 2: You have just deleted the settings

Launch 4 full gate opening and closing movements.

Upon completion of the 4 movements, indicator light  on the control unit must be CONTINUOUSLY LIT.

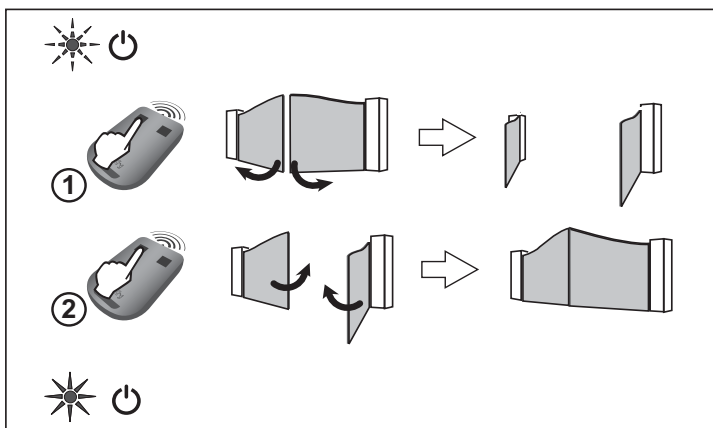

!
The gate movements must not be interrupted (complete opening/closing).
If they are interrupted, programming will resume the next time the opening command is issued.

If indicator light  flashes, relaunch auto-programming of the leaf travel (4 full opening and closing movements).

If the indicator light  continues to flash, refer to "Diagnostics" page 31.

If the gate re-opens at the end of the closing movement, loosen and offset the gate leaf brackets slightly towards the centre of the gate.

!
WARNING
Once installation is complete, it is essential to check that the obstacle detection complies with annex A of the standard EN 12 453.

2.4 Closing the control unit

1

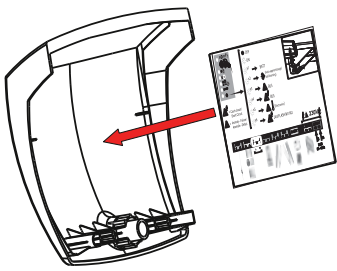

Affix summary label (g) to the back of the control unit cover.

2

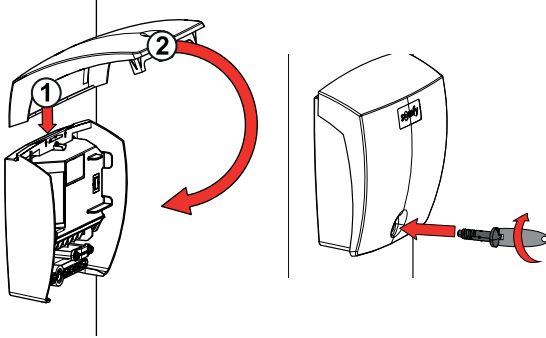

Close the control unit and screw in the cover.

2.5 Standby/Reactivating the control electronics



Once the auto-programming process has been completed, the electronics automatically switch to standby after 5 minutes of inactivity to save energy. In standby mode, all indicator lights are off.

To check whether the motorisation is switched on or to check/modify the parameter setting, press the  button for 2 seconds to reactivate the electronics. The electronics will automatically switch to standby after 5 minutes of inactivity.

2.6 Completely opening and closing the gate



The remote controls supplied with the kit are already memorised and programmed so that button 1 on the remote controls activates complete opening of the gate.

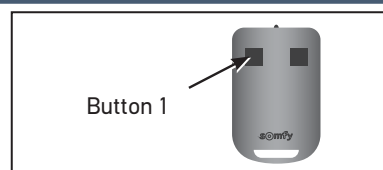

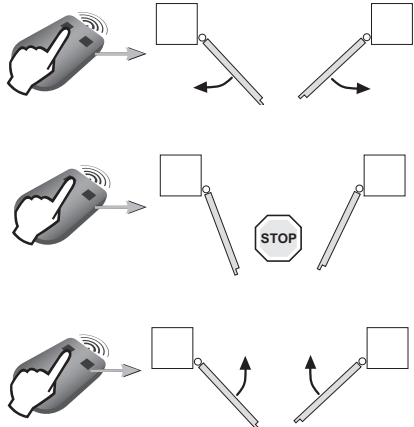

- Gate closed: press button 1 on the remote control to open the gate fully.
- Gate moving: Press button 1 on the remote control to stop the gate.
- Gate open: Press button 1 on the remote control to close the gate.

2.7 Obstacle detection

If an obstacle is detected (abnormal force on the motorisation):

- **When the gate is opening:** the gate will stop.
- **When the gate is closing:** the gate will stop and reopen.

2.8 User training

All users must be trained on how to safely use this motorised gate (standard use and unlocking principle) and on the mandatory periodic checks.



For your safety, these operations must be carried out with the power supply switched off.



You are advised to perform auto-programming of the gate travel before connecting the accessories (photoelectric cells, flashing light, etc.)

3.1 Photoelectric cells



It is not possible to connect a second set of photoelectric cells on this motorisation.

► Installation

After wiring the photoelectric cells:

- switch the motor on again,
- start a gate opening or closing procedure.

The photoelectric cells are recognised by the control electronics once this movement is complete.

► Operation with photoelectric cells

If the cells are blocked when closing the gate, the gate will stop and reopen.

► In the event of photoelectric cell disconnection

After disconnecting the photoelectric cells, switch the motor on again and perform the “Deactivating automatic closing” procedure, page 26.

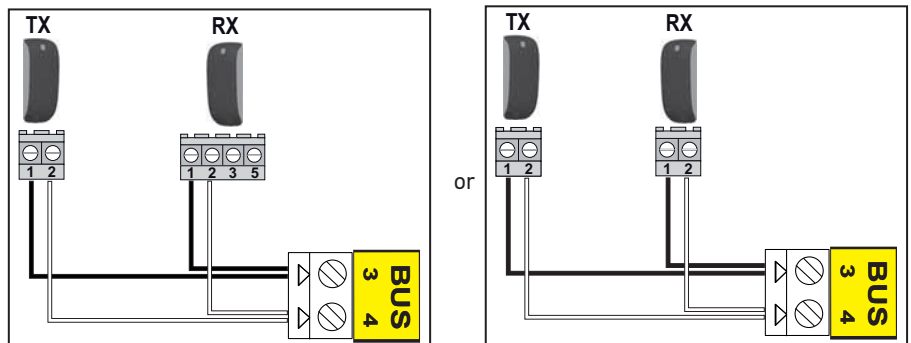

3.2 Flashing light



10 W - 24 V bulb MAXIMUM - use of a bulb with power greater than 10 W- 24 V can cause motorisation malfunctions.

► Operation of the flashing light

The light flashes while the gate is moving.

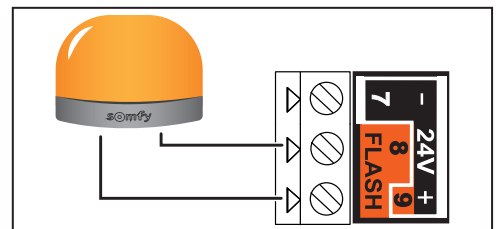

3.3 Battery (optional)



This accessory is not compatible with solar power.



To increase the operation time of the battery during use, the wired controls are deactivated and the gate can only be controlled using the remote controls and the radio control points.

The backup battery ensures the operation of the gate in the event of an electrical power failure.

The  indicator light flashes (1 pulse) when the motor is battery-operated.

► Battery technical data

- Battery life: 10 continuous cycles or 24 hours on a gate in perfect condition.
- Optimum charge time before using the battery: 48 hours.
- Service life: 3 years.

To ensure an optimum battery life, switch the gate's electric power supply off at least 3 times a year to run a number of cycles using the battery.

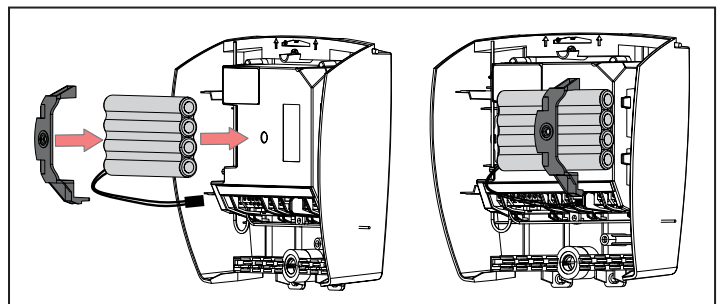

3.4 Offset antenna (optional)



The antenna wire can be replaced with an offset antenna with a greater range. This is placed on top of the pillar and must be clearly accessible.

It is connected to terminals 1 and 2 (blue "ANT" label) on the control unit:

- the wire core on terminal 1,
- the ground strap on terminal 2.

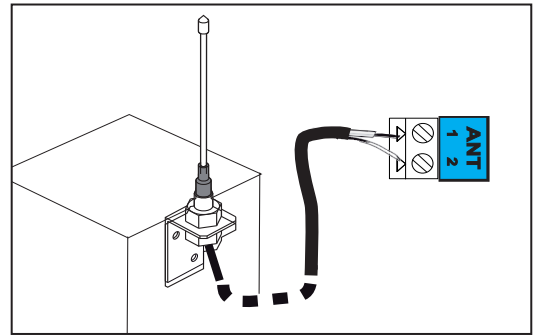

3.5 Video entry phone (optional)



This accessory is not compatible with solar power. Only connect one non-powered dry contact.

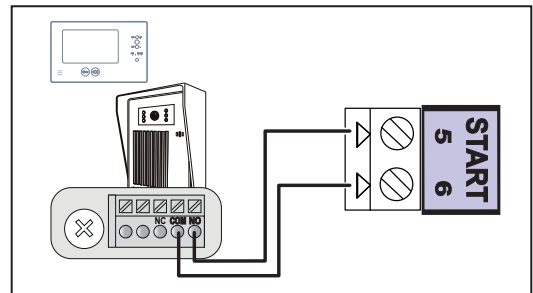

3.6 Key lock (optional)



This accessory is not compatible with solar power.

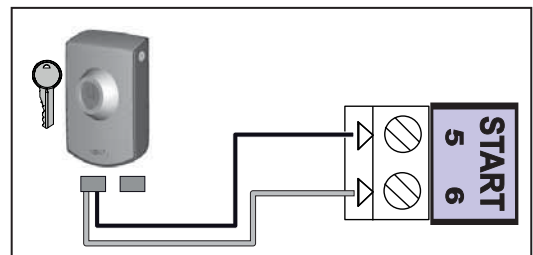

3.7 Area lighting (optional)



This accessory is not compatible with solar power. Only use halogen or incandescent bulbs for area lighting, 500 W maximum.

► Area lighting operation

Area lighting comes on each time the motor is started up. It goes out automatically 1 minute and 30 seconds after movement has finished.

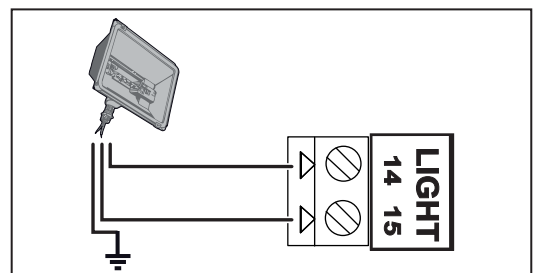

3.8 Solar power (optional)



Never connect your motor to a 230 V power supply when it is connected to a solar power supply, as this may damage the motor's electronics unit.

When the motor is running on the solar feed:

- only the remote controls and radio control points can be used to control the gate (wired controls are deactivated),
- the wired safety accessories (photoelectric cells, flashing light) remain active.

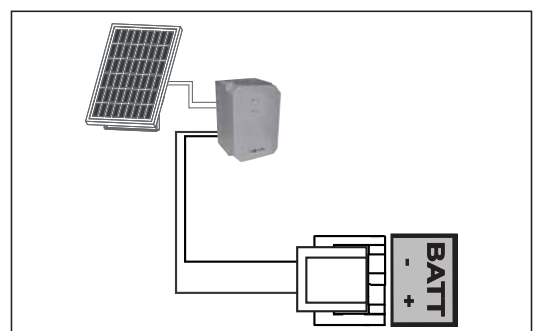

4.1 Pedestrian opening

▶ Pedestrian opening operation

<p>Pedestrian opening(motor M1) by pressing the activated button.</p>	
<p>Stop when moving by pressing the activated button again.</p>	
<p>Close by pressing the activated button again.</p>	

▶ Activating the pedestrian opening

i Button 1 on 2- or 4-button remote controls cannot be programmed to control pedestrian opening. See "Description of the remote controls" page 27 for more information.

<p>1</p> <p>Press the button on the control electronics for 2 seconds. The indicator light comes on.</p>	<p>2</p> <p>Position the remote control on the control electronics target.</p>	<p>3</p> <p>Press button 2 on the remote control. The "RADIO" and indicator lights come on then go out. Pedestrian opening is activated on this button.</p>
---	---	--

i Move away from the control electronics when testing pedestrian opening.

▶ Deactivating pedestrian opening

Repeat the "Activate pedestrian opening" procedure using the button for which the pedestrian opening must be deactivated. The indicator light comes on then goes out. The pedestrian opening is deactivated on this button.

4.2 Automatic closing

▶ Automatic closing operation

Press button 1 on the remote control to open the gate.

The gate closes again after 30 seconds or 5 seconds if the photoelectric cells detect a passage.

The automatic closing can be interrupted by pressing button 1 on the remote control. To then close the gate, press button 1 on the remote control again.



▶ Activating automatic closing



Automatic closing can only be activated if the photoelectric cells are connected and recognised by the motor's control electronics.

1



Press the  button on the control electronics for 2 seconds.
The indicator light  comes on.

2

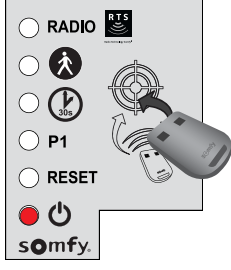

Position the remote control on the control electronics target.

3

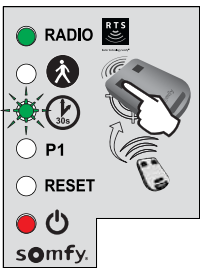

Keep button 1 of the remote control depressed until the  indicator light flashes.

i Once step 3 has been carried out, you can carry out the following steps remotely (without placing the remote control on the target).

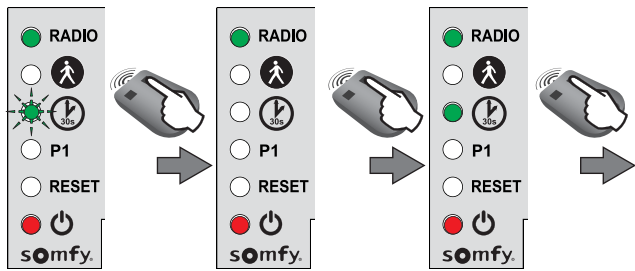

4





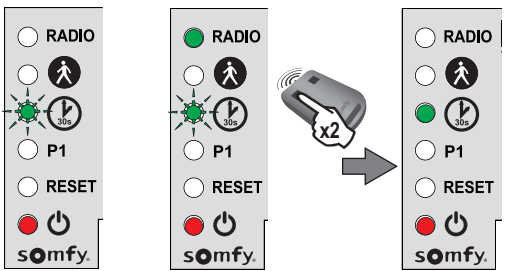





Keep button 2 on the remote control depressed until the  indicator light goes out and is then lit constantly.

5

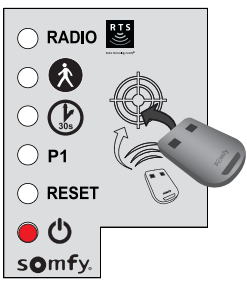
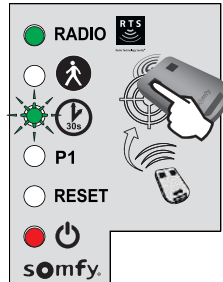

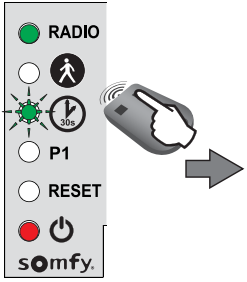
When you release button 2, the  indicator light flashes; press button 1 on the remote control twice. The  indicator light remains lit.
Automatic closing is activated.

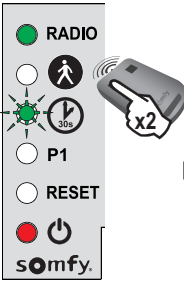
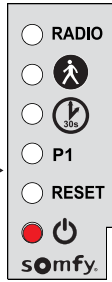
▶ Deactivating automatic closing

<p>1</p>  <p>Press the  button on the control electronics for 2 seconds. The indicator light  comes on.</p>	<p>2</p>  <p>Position the remote control on the control electronics target.</p>	<p>3</p>  <p>Keep button 1 of the remote control depressed until the  indicator light flashes.</p>
<p>4</p>  <p>Press button 2 on the remote control. The  indicator light flashes.</p>	<p>5</p>  <p>Press button 1 on the remote control twice.</p>	<p>6</p>  <p>The indicator light  is off. Automatic closing is deactivated.</p>

5.1 Description of the remote controls

Depending on the choice of parameter settings, Somfy RTS remote controls can control:

- complete opening of the gate
- pedestrian opening of the gate
- another Somfy RTS device (example: garage door motor, roller shutter, etc.)

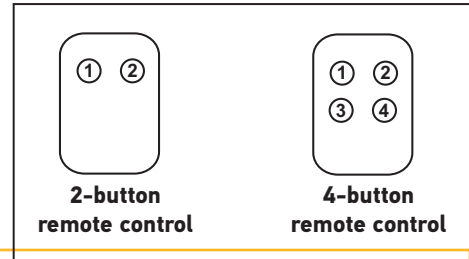

The remote controls supplied with the kit are already memorised and programmed so that button 1 on the remote controls activates complete opening of the gate.



You can memorise up to 16 control points (remote control, other radio control point). If you memorise a 17th control point, the first point memorised will automatically be deleted.



If you wish to program pedestrian opening, it must be programmed on the button following programming of the complete opening (e.g. complete opening controlled by button 2, pedestrian opening controlled by button 3). It is not possible to programme pedestrian opening on button 1 of the remote controls.

► Possibilities for programming the 2-button remote control

	Button 1	Button 2
Possibility 1	Complete opening	Pedestrian opening or other Somfy RTS automatism
Possibility 2	Another Somfy RTS device	Complete opening

► Possibilities for programming the 4-button remote control

	Button 1	Button 2	Button 3	Button 4
Possibility 1	Complete opening	Pedestrian opening or other Somfy RTS automatism	Another Somfy RTS automatism	Another Somfy RTS automatism
Possibility 2	Another Somfy RTS automatism	Complete opening	Pedestrian opening or other Somfy RTS automatism	Another Somfy RTS automatism
Possibility 3	Another Somfy RTS automatism	Another Somfy RTS automatism	Complete opening	Pedestrian opening or other Somfy RTS automatism
Possibility 4	Another Somfy RTS automatism	Another Somfy RTS automatism	Another Somfy RTS automatism	Complete opening

► Using a 3-button remote control

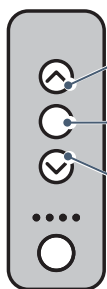

Opening

To open the gate completely, press the “Up” button on the remote control.

Stop

To stop the gate while it is moving, press the central button on the remote control.

Closing





To close the gate, press the “Down” button on the remote control.





The 3-button remote control cannot be used to change the motor settings.

5.2 Adding a remote control

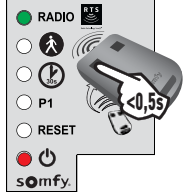
▶ 2- or 4-button remote control

<p>1</p>  <p>Press the  button on the control electronics for 2 seconds. The indicator light  comes on.</p>	<p>2</p>  <p>Position the new remote control to be programmed on the control electronics target.</p>	<p>3</p>  <p>Briefly press the button on the remote control to be programmed. The RADIO indicator light will come on then go out when you release the button on the remote control. Complete opening is programmed on this button.</p>
---	--	---

▶ 3-button remote control

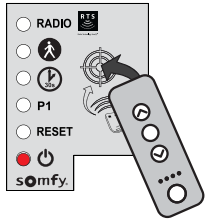
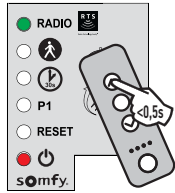
<p>1</p>  <p>Press the  button on the control electronics for 2 seconds. The indicator light  comes on.</p>	<p>2</p>  <p>Position the new remote control to be programmed on the control electronics target.</p>	<p>3</p>  <p>Briefly press a button on the remote control to be programmed. The RADIO indicator light will come on then go out when you release the button on the remote control. The remote control has been memorised.</p>
--	---	--

5.3 Deleting a remote control

see "Clearing the settings" page 30.





The motorisation must be disconnected from any power supply during cleaning and maintenance and when parts are replaced.

6.1 Assistance

If the fault remains or for any other problem or enquiry relating to your motorisation, visit www.somfy.com

6.2 Replacing the remote control battery

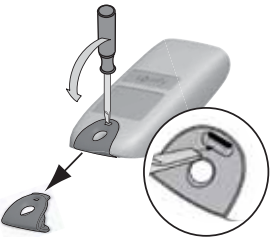

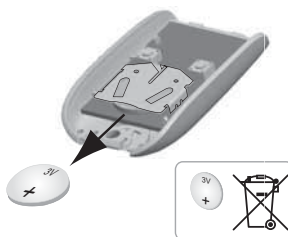
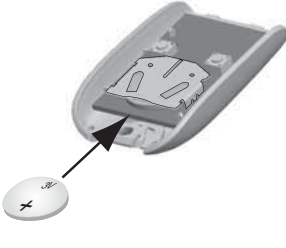



The service life of the battery is generally 2 years.

<p>1</p>  <p>Remove the clip from the remote control.</p>	<p>2</p>  <p>Insert the screwdriver in the slot and lift the cover.</p>	<p>3</p>  <p>Remove the battery using a screwdriver.</p>	<p>4</p>  <p>Replace the battery (3 V CR 2430 or CR 2032).</p>
---	---	---	--

6.3 Clearing the settings

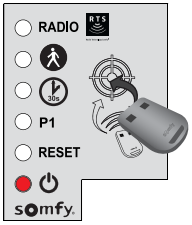
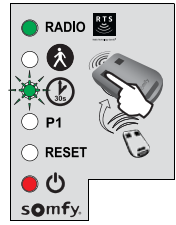
When should I clear the settings?

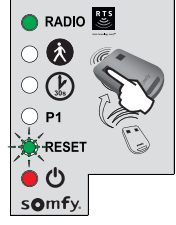
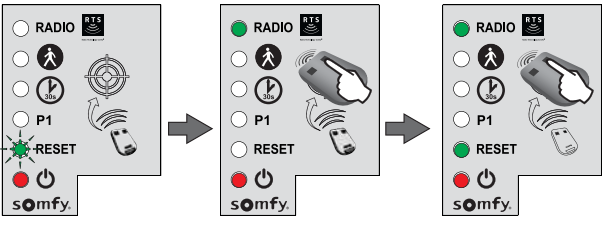
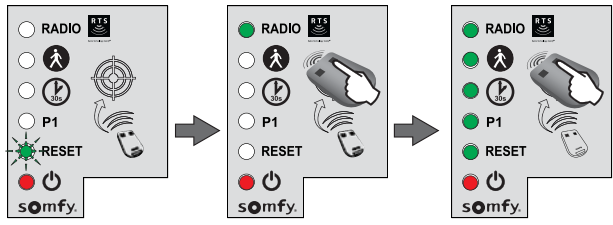
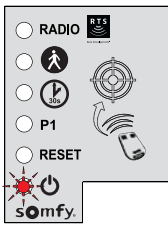
- After programming the gate leaf travel, if you change the opening position stop or if you modify the motor wiring.
- If the gate opens at random due to normal wear of the gate.

<p>1</p>  <p>Press the  button on the control electronics for 2 seconds. The indicator light  comes on.</p>	<p>2</p>  <p>Place the memorised remote control on the target.</p>	<p>3</p>  <p>Keep button 1 of the remote control depressed until the indicator light  flashes.</p>	<p>4</p>  <p>Press button 1 on the remote control once. The "RESET" indicator light flashes.</p>
<p>5 To clear the settings*</p>  <p>Keep button 2 of the remote control depressed until the "RESET" indicator light comes on.</p>		<p>5 To clear the settings* and the memorised remote controls/control points</p>  <p>Keep button 2 of the remote control depressed until all the indicator lights come on.</p>	
<p>6</p>  <p>The indicator light  flashes twice (see "Gate travel auto-programming" page 20).</p>			

*Gate travel, deactivation of the settings, etc.

6.4 Unlocking/locking the motors

When unlocking the motors, the gate may be manoeuvred manually if there is an electrical fault.

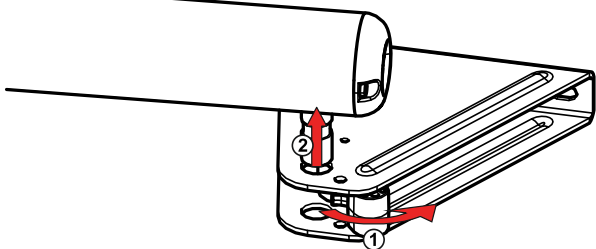
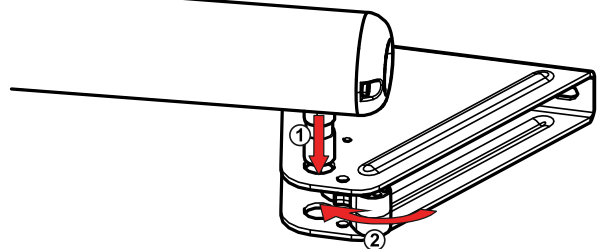
<p>1</p>  <p>Unlocking the motors Unclip the unlocking mechanism, then remove the cylinder from the gate leaf mounting bracket.</p>	<p>2</p>  <p>Locking the motors Fit the cylinder. Clip the unlocking mechanism on the catch to secure it.</p>
--	---

6.5 Diagnostics





DIAGNOSTICS		REPAIRS
The motors are not responding to remote control commands	The remote control range is reduced	<ul style="list-style-type: none"> - Check the remote control battery (see “Replacing the remote control battery”, page 29). - Check the control unit antenna (wiring, position, see page 16). - Check that there are no outside elements that may be interfering with the radio signal (electric pylon, metal reinforced walls, etc.). If this is the case, fit an offset antenna.
	Non-memorised remote control Poorly wired motors	Memorise the remote control (see page 28). Check the motor wiring (see page 18).
The control unit's ⏻ indicator light is off	The electronics unit is on standby	Press button  for 2 seconds to reactivate the electronics.
	No power supply to the control electronics	<ul style="list-style-type: none"> - Check the power supply. - Check the power supply cable.
The control unit's ⏻ indicator light flashes:		
1 flash	Operation using the backup battery	Check the mains power supply.
2 flashes	Motor waiting for auto-programming	Start the gate travel auto-programming procedure (see page 20).
3 flashes	Faulty photoelectric cells	<ul style="list-style-type: none"> - Check that there is nothing obstructing the cells. - Check the cell alignment. - Check the cell wiring (see page 22). - If the cells are deliberately disconnected, perform the “Deactivating automatic closing” procedure, page 26.
4 flashes	Permanent control on “START” of the electronic unit (terminals 5-6)	Check the accessories connected to the electronic unit's “START” output.
5 flashes	Electronics thermal safety activated	Allow the electronics to cool down until the ⏻ indicator light comes on continuously.
6 flashes	Short circuit of electronics unit's “BUS” output (terminals 3-4)	Check the accessories connected to the electronic unit's “BUS” output.
	Short circuit of electronics unit's “24 V output” (terminals 7-9)	Check the accessory connected to the electronic unit's “24 V” output.
	Short circuit of the electronics unit's “flashing light” (terminals 8-9)	Check the wiring of the flashing light(see page 22).
	Motor short circuit	Check the motor wiring (see page 18).
7 flashes	Electrical fault	Contact Somfy assistance.
The gate reopens at the end of the closing motion		Unscrew the gate leaf brackets and offset them slightly towards the centre of the gate.

Power supply	230 V-50Hz/24 V (with solar power)
Motor type	24 V
Motor output	120 W
Max. power consumed (with area lighting)	600 W
Standby consumption	3 W (without accessories)
Maximum frequency of movements per day	20 cycles per day 10 cycles per day using solar power
Opening time	20 s minimum to 90°
Automatic obstacle detection	Compliant with standard EN 12 453
Operating temperature	-20°C to +60°C
Thermal protection	Yes
Index protection rating	IP 44
Integrated radio receiver	Yes
Remote controls: - Radio frequency - Range in field of use - Storage quantity	433.42 MHz, < 10mW ~ 30 m 16
Possible connections: - Flashing light output - Lighting output - Accessories power supply output - Backup battery input - Photoelectric cells input - Dry contact type control input	Flashing, 24 V, 10 W maximum 500 W max. for 230 V (halogen or incandescent lights only) 24 Vdc / 15 W max Yes Yes Yes (does not operate in the event of battery or solar power supply)

Inhaltsverzeichnis

Sicherheitshinweise	2	3 Verkabelung des Zubehörs	22
- Wichtige Informationen	2	3.1 Fotozellen	22
- Zustand des mit dem Antrieb zu bewegenden Tors	2	3.2 Signalleuchte	22
- Elektrische Installation	2	3.3 Batterie (Option)	22
- Kabelführung	3	3.4 Externe Zusatzantenne (Option)	23
- Sicherheitshinweise bei der Installation des Antriebs	3	3.5 Video-Türsprechanlage (Option)	23
- Sicherheitshinweise bei der Benutzung	3	3.6 Schlüsselschalter (Option)	23
- Sicherheitshinweise bei der Wartung	4	3.7 Umfeldbeleuchtung (Option)	23
- Sicherheitshinweise zu Batterien	4	3.8 Solarstromversorgung (Option)	23
- Recycling und Entsorgung	4	4 Erweiterte Einstellungen	24
- Normen	4	4.1 Fußgängeröffnung	24
- Gefahrenvermeidung	4	- Funktion der Fußgängeröffnung	24
Produktvorstellung	6	- Aktivierung der Fußgängeröffnung	24
- Inhalt des Pakets	6	- Deaktivierung der Fußgängeröffnung	24
- Produktbeschreibung	7	4.2 Automatischer Zulauf	25
- Abmessungen	7	- Funktion des automatischen Zulaufs	25
- Bestimmungsgemäße Verwendung	7	- Aktivierung des automatischen Zulaufs	25
- Übersicht über die Anlage	8	- Deaktivierung des automatischen Zulaufs	26
- Erläuterung der Steuerelektronik	9	5 Einlernen von Funksendern	27
Voraussetzungen für die Installation	9	5.1 Beschreibung der Funksender	27
- Vor der Montage zu prüfende Punkte	9	- Programmiermöglichkeiten der Funksender mit 2 Tasten	27
- Elektrische Vorbereitung	10	- Programmiermöglichkeiten der Funksender mit 4 Tasten	27
- Bereitzustellende Kabel	10	- Verwendung eines Funksenders mit 3 Tasten	27
- Für die Installation benötigtes Werkzeug (nicht im Lieferumfang)	11	5.2 Einlernen eines Funksenders	28
- Für die Installation benötigte Eisenwaren (nicht im Lieferumfang)	11	- Funksender mit 2 und 4 Tasten	28
1 Installation	12	- Funksender mit 3 Tasten	28
1.1 Ermittlung der Maße	12	5.3 Löschen der Funksender	28
1.2 Befestigung der Winkel an den Pfeilern	13	6 Störungsbeseitigung	29
- Anzeichnen der Achsen AM und AH	13	6.1 Support	29
- Herstellen der Bohrungen an den Pfeilern	13	6.2 Austausch der Batterie des Funksenders	29
- Anbringung des Befestigungswinkels am Pfeiler	14	6.3 Einstellungen löschen	30
- Anbringung der Spindel am Befestigungswinkel	14	6.4 Entriegeln/Verriegeln der Antriebe	30
1.3 Befestigung der Antriebe an den Torflügeln	14	6.5 Diagnose	31
1.4 Installation des Steuerkastens	16	7 Technische Daten	32
- Position des Steuerkastens	16		
- Einlegen der Dichtungsschnur	16		
- Überprüfung der Position der Antenne	16		
- Befestigung des Steuerkastens	16		
1.5 Anschluss der Antriebe	18		
1.6 Anschluss an die Netzstromversorgung	18		
2 Inbetriebnahme und übliche Verwendung	19		
2.1 Einschalten der Anlage	19		
2.2 Einstellung des Öffnungsanschlags	19		
2.3 Selbsteinlernfunktion für den Torweg	20		
2.4 Schließen des Steuerkastens	21		
2.5 Wechsel der Steuerelektronik in den Standby-/Betriebsmodus	21		
2.6 Vollöffnung und Schließung des Tors	21		
2.7 Hinderniserkennung	21		
2.8 Schulung der Benutzer	21		

› Sicherheitshinweise

 Dieses Symbol weist auf eine Gefahr hin, deren verschiedene Gefährdungsgrade nachstehend beschrieben sind.
 GEFAHR
Weist auf eine Gefahr hin, die sofort zu schweren bis tödlichen Verletzungen führt.
 WARNUNG
Weist auf eine Gefahr hin, die zu schweren bis tödlichen Verletzungen führen kann.
 VORSICHT
Weist auf eine Gefahr hin, die zu leichten bis mittelschweren Verletzungen führen kann.
ACHTUNG
Weist auf eine Gefahr hin, die das Produkt beschädigen oder zerstören kann.

 WARNUNG
WARNHINWEIS - Wichtige Sicherheitshinweise Für die Gewährleistung der Sicherheit von Personen ist es wichtig, dass diese Hinweise befolgt werden, da es bei unsachgemäßer Installation zu schweren Verletzungen kommen kann. Bewahren Sie diese Sicherheitshinweise gut auf. Der Monteur muss unbedingt alle Benutzer unterweisen, um eine sichere Verwendung des Antriebs gemäß den Anweisungen der Bedienungsanleitung zu gewährleisten. Die Anleitungen müssen dem Endbenutzer übergeben werden.

› Wichtige Informationen

Dieses Produkt ist ein Antrieb für ein Torflügelator im Wohnbereich gemäß Norm EN 60335-2-103, mit der es konform ist. Zweck dieser Anleitung ist es, die Anforderungen der genannten Normen zu erfüllen und somit die Sicherheit von Sachen und Personen zu gewährleisten.

 WARNUNG
Jede Verwendung des Produkts für Anwendungen, die nicht in dieser Anleitung beschrieben sind, ist untersagt (siehe Abschnitt „Bestimmungsgemäße Verwendung“ der Anleitung). Die Verwendung von Zubehör oder Komponenten, die nicht von Somfy genehmigt sind, ist untersagt, da in einem solchen Fall nicht für die Sicherheit der Personen garantiert werden kann. Somfy kann nicht für Schäden haftbar gemacht werden, die auf die Nichtbefolgung der Hinweise in dieser Anleitung zurückzuführen sind.

Wenn bei der Installation des Antriebs Fragen auftauchen und für alle weiterführenden Informationen steht die Internetseite www.somfy.com zur Verfügung. Diese Anleitung kann im Falle von Änderungen der Normen oder des Antriebs jederzeit geändert werden.

› Zustand des mit dem Antrieb zu bewegenden Tors

Stellen Sie vor der Montage des Antriebs sicher, dass:

- das Tor in gutem mechanischem Zustand ist.
- das Tor unabhängig von seiner Position stabil ist.
- das Tragwerk zur Aufnahme des Tors eine stabile Befestigung des Antriebs zulässt. Bei Bedarf entsprechend verstärken.
- das Tor sich von Hand mit einer Kraft von weniger als 150 N problemlos öffnen und schließen lässt.
- der auf dem Antrieb angegebene Temperaturbereich am Installationsort eingehalten wird.

ACHTUNG
Vermeiden Sie Wasserspritzer auf den Antrieb. Der Antrieb darf nicht in einer explosionsgefährdeten Umgebung installiert werden.

 WARNUNG
Stellen Sie sicher, dass durch die Bewegung des angetriebenen Segments zwischen diesem und angrenzenden feststehenden Teilen aufgrund der Öffnung des angetriebenen Segments keine Gefahrenzonen entstehen können (Verletzungen durch Quetschen, Scheren oder Klemmen) oder an der Anlage entsprechend darauf aufmerksam gemacht wird (siehe „Gefahrenvermeidung“).

Befestigen Sie Schilder, die vor der Quetschgefahr warnen, dauerhaft an einem gut sichtbaren Ort oder in der Nähe eventueller fest installierter Bedieneinrichtungen.

› Elektrische Installation

 GEFAHR
Der elektrische Anschluss muss die Normen des Landes erfüllen, in dem der Antrieb installiert wird, und muss von einem Fachmann durchgeführt werden.

 GEFAHR
Die Anschlussleitung darf nur den Antrieb versorgen und muss wie folgt abgesichert sein: <ul style="list-style-type: none"> • durch eine Sicherung oder einen Leistungsselbstschalter mit 10 A • durch einen Fehlerstrom-Schutzschalter (30 mA) Die Trennung vom Stromnetz muss alle Pole erfassen. Die Trennschalter, die die Trennung aller Pole der Spannungsversorgung der fest installierten Geräte bewirken sollen, müssen unmittelbar an die Klemmen der Spannungsversorgung angeschlossen werden. Dabei muss eine Trenndistanz der Kontakte an allen Polen vorliegen, um die vollständige Trennung unter den Überspannungsbedingungen der Kategorie III zu gewährleisten. Die Niederspannungsleitungen, die der Witterung ausgesetzt sind, müssen mindestens dem Typ H07RN-F entsprechen. Die Installation eines Blitzschutzes wird empfohlen (max. 2 kV Restspannung).

► Kabelführung

GEFAHR

In der Erde verlegte Kabel müssen in einem Schutzrohr verlegt werden, dessen Durchmesser groß genug ist, um die Kabel des Antriebs und der Zubehörteile aufnehmen zu können.

Kabel, die nicht in der Erde verlegt werden, müssen in einem Kabelkanal geführt werden, der für das Überfahren mit Fahrzeugen ausgelegt ist (Teile-Nr. 2400484).

► Sicherheitshinweise bei der Installation des Antriebs

WARNUNG

Legen Sie vor der Montage alle Schmuckstücke ab (Armband, Kette und andere).

Tragen Sie beim Bewegen der Teile, bei Bohr- und Schweißarbeiten eine geeignete Sicherheitsausrüstung (Schutzbrille, Handschuhe, Gehörschutz etc.).

GEFAHR

Stellen Sie den Stromanschluss (Netz, Batterie oder Solar) erst nach Abschluss der Montage her.

WARNUNG

Die in diesem Kit gelieferten Bauteile dürfen auf keinen Fall verändert oder zusätzliche Komponenten verwendet werden, die nicht in dieser Anleitung vorgesehen sind.

Behalten Sie das Tor im Auge, während es sich bewegt, und halten Sie alle Personen bis zum Abschluss der Installation fern.

Der Antrieb darf nicht mit Klebstoffen befestigt werden.

WARNUNG

Die manuelle Entriegelung kann eine unkontrollierte Bewegung des Tors zur Folge haben.

Befestigen Sie das Schild mit Hinweisen zur manuellen Entriegelung dauerhaft in der Nähe des entsprechenden Betätigungsorgans.

WARNUNG

Alle fest installierten Betätigungsverfahren müssen in einer Höhe von mindestens 1,5 m und im Sichtbereich des Tors, jedoch fern von beweglichen Teilen montiert werden.

Vergewissern Sie sich nach der Montage, dass:

- der Mechanismus richtig eingestellt ist.
- die Vorrichtung zur manuellen Entriegelung ordnungsgemäß funktioniert.
- der Antrieb die Richtung wechselt, wenn das Tor auf einen 50 mm großen Gegenstand auf halber Höhe des Tors stößt.

WARNUNG

Bei Automatikbetrieb oder bei einer Betätigung ohne Sichtkontakt muss eine Lichtschranke installiert werden.

Der Antrieb im Automatikbetrieb funktioniert mindestens in einer Richtung ohne absichtliche Betätigung seitens des Benutzers.

Wenn das Tor automatisch betrieben werden soll oder sich in einen öffentlichen Bereich öffnet, ist in einigen Ländern die Installation einer Signalleuchte gesetzlich vorgeschrieben.

► Sicherheitshinweise bei der Benutzung

WARNUNG

Dieser Antrieb ist zur Verwendung durch Kinder ab dem Alter von 8 Jahren und durch Personen mit eingeschränkten körperlichen, sensorischen und geistigen Fähigkeiten sowie durch Personen ohne Erfahrung oder Kenntnisse geeignet, wenn diese entsprechend beaufsichtigt oder in die sichere Anwendung des Antriebs eingewiesen werden und wenn alle etwaigen Gefahren berücksichtigt worden sind. Lassen Sie Kinder nie mit den Bedieneinrichtungen des Tors spielen. Halten Sie Funksender außer der Reichweite von Kindern. Die Reinigung und Wartung durch den Benutzer darf nicht von Kindern durchgeführt werden.

Der Schalldruckpegel des Antriebs beträgt maximal 70 dB(A). Hierbei sind Geräusche nicht berücksichtigt, die von der Struktur ausgehen, an der der Antrieb angebracht ist.

WARNUNG

Alle Benutzer müssen vom Installateur über die Verwendung des Antriebs gemäß den Vorgaben in dieser Anleitung informiert werden. Es ist unbedingt sicherzustellen, dass nicht unterwiesene Personen das Tor nicht in Bewegung setzen können.

Der Benutzer muss das Tor bei der Ausführung aller Bewegungen beobachten und Personen fernhalten, bis das Tor vollständig geöffnet oder geschlossen ist. Behindern Sie die Torbewegungen nicht absichtlich.

WARNUNG

Bei Störungen ist die Stromversorgung zu trennen. Entriegeln Sie dann umgehend den Antrieb, um Zugriff auf diesen nehmen zu können und wenden Sie sich an den Support von Somfy.

Versuchen Sie nicht, das Tor von Hand zu öffnen, wenn der Antrieb nicht entkoppelt ist. Achten Sie darauf, dass keine natürlichen Hindernisse (Äste, Steine, hohes Gras etc.) die Bewegung des Tors behindern können.

► Sicherheitshinweise bei der Wartung

! GEFAHR

Der Antrieb muss während der Reinigung, Wartung und beim Austausch von Bauteilen von der Stromversorgung getrennt sein.

! WARNUNG

Prüfen Sie einmal pro Monat:

- die Anlage, um eventuelle Spuren von Verschleiß oder eine Beschädigung der Kabel und der Montage zu erkennen.
- ob der Antrieb die Richtung wechselt, wenn das Tor auf einen 50 mm großen Gegenstand auf halber Höhe des Tors stößt.

Verwenden Sie den Antrieb nicht, wenn eine Reparatur oder Einstellung erforderlich ist. Tore in schlechtem Zustand sind instand zu setzen, zu verstärken oder ggf. umzubauen.

Verwenden Sie bei Wartungs- und Reparaturarbeiten ausschließlich Originalersatzteile.

Alle technischen, elektronischen oder mechanischen Änderungen am Antrieb müssen gemäß Anweisungen des Supports von Somfy erfolgen.

Wenn die Anlage mit einer Lichtschranke und/oder einer Signalleuchte ausgestattet ist, reinigen Sie die Lichtschranke und die Signalleuchte regelmäßig.

► Sicherheitshinweise zu Batterien

! GEFAHR

Halten Sie Batterien/Knopfbatterien/Akkus außerhalb der Reichweite von Kindern. Bewahren Sie diese an einem Ort außerhalb der Reichweite von Kindern auf. Sie können sonst von Kindern oder Haustieren verschluckt werden. Lebensgefahr! Sollte es dennoch zu einem Verschlucken kommen, wenden Sie sich unverzüglich an einen Arzt oder gehen Sie in die Notaufnahme des Krankenhauses.

Achten Sie darauf, Batterien nicht kurzzuschließen, in ein Feuer zu werfen oder neu aufzuladen. Hierbei besteht Explosionsgefahr.

► Recycling und Entsorgung

Wenn eine Batterie installiert ist, muss diese vor Entsorgung des Antriebs ausgebaut werden.

-  Gebrauchte Batterien der Funksender oder eventuell im Antrieb installierte Batterien dürfen nicht mit dem Hausmüll entsorgt werden. Geben Sie diese bei einer Recycling-Sammelstelle ab.
-  Entsorgen Sie Ihren nicht mehr verwendeten Antrieb nicht mit dem Hausmüll. Lassen Sie den Antrieb vom Lieferanten zurücknehmen oder nutzen Sie die von der Kommune bereitgestellten Möglichkeiten der getrennten Müllsammlung.

► Normen

CE Somfy SAS erklärt, dass das in diesen Anleitungen beschriebene Produkt bei Anwendung gemäß diesen Anweisungen mit den wesentlichen Anforderungen der anwendbaren Europäischen Richtlinien konform ist, insbesondere mit der Maschinenrichtlinie 2006/42/EG sowie der Richtlinie 2014/53/EU über Funkanlagen.

Der vollständige Text der EG-Konformitätserklärung ist unter der Internet-Adresse www.somfy.com/ce verfügbar. Antoine CREZE, Leiter Regulierung, Cluses

► Gefahrenvermeidung

Gefahrenbereiche (Zonen)

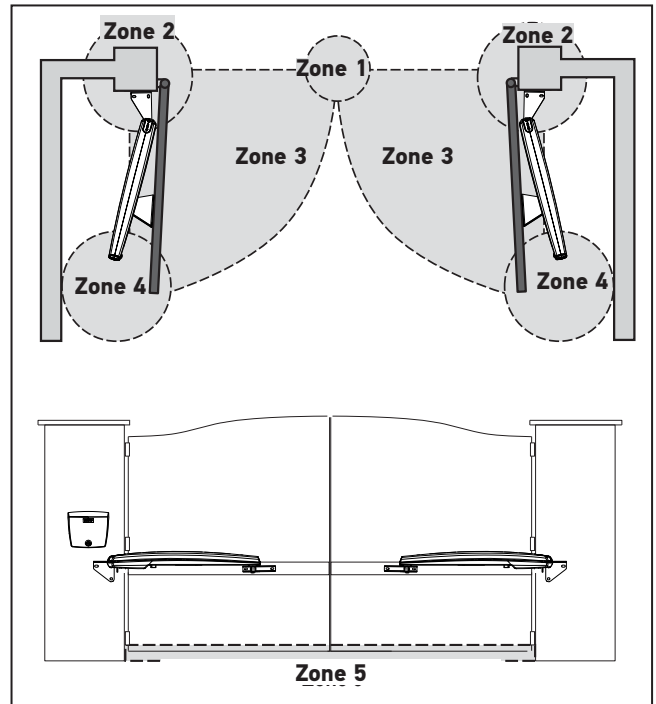

Maßnahmen zur Eliminierung von Gefahren

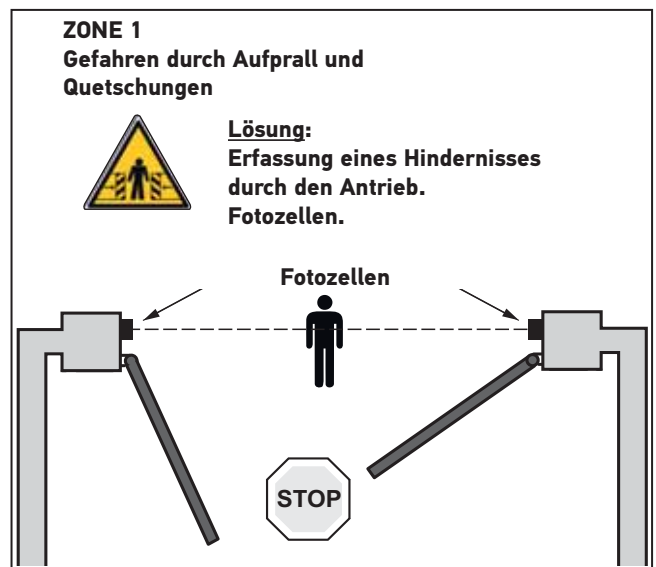

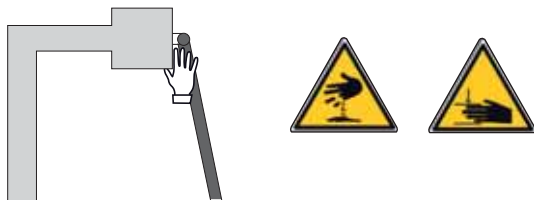
ZONE 2**Gefahren der Verletzung der Hände durch Quetschungen**

und Scherbewegungen

Lösung:

Wenn an der Installation die Gefahr einer Verletzung der Hände durch Scherbewegungen besteht, müssen Sie entweder:

- einen Abstand von mindestens 10 cm zwischen Torflügel und Pfeiler/Mauer vorsehen.
- oder die Ecke des Pfeilers abschrägen, ohne jedoch dessen Stabilität zu gefährden.

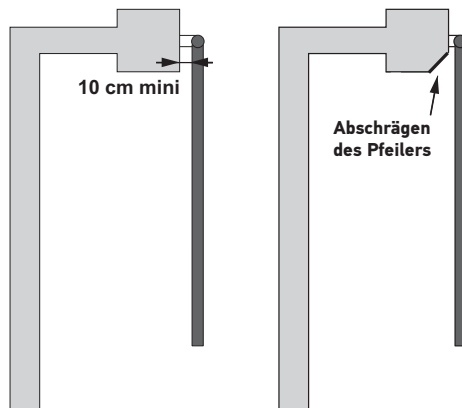
**ZONE 3****Gefahr durch Aufprall****Lösung:**

Erfassung eines Hindernisses durch den Antrieb.

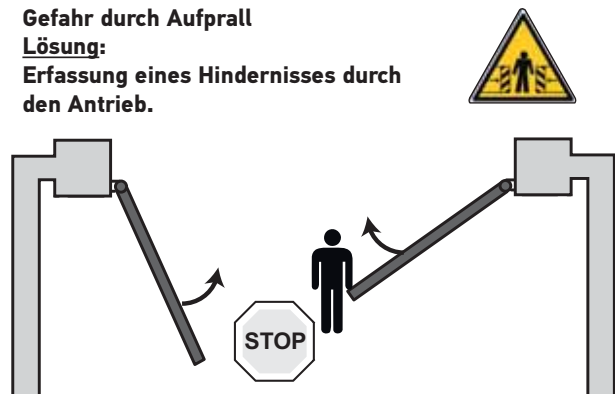
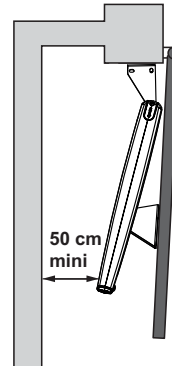
**ZONE 4****Gefahr des Steckenbleibens und von Quetschungen****Lösung:**

Erfassung eines Hindernisses durch den Antrieb.

Wenn die Gefahr besteht, zwischen Torflügeln und den entsprechenden feststehenden Teilen der Anlage stecken zu bleiben, muss ein Mindestabstand von 50 cm zwischen den Torflügeln und den feststehenden Teilen bleiben.

ZONE 5**Gefahr des Mitschleifens der Füße****Lösung:**

Damit zwischen Torflügel und Boden keine Gefahr für die Füße besteht, muss der Abstand zwischen der Unterkante der Torflügel und dem Boden mindestens 12 cm oder höchstens 5 mm betragen.

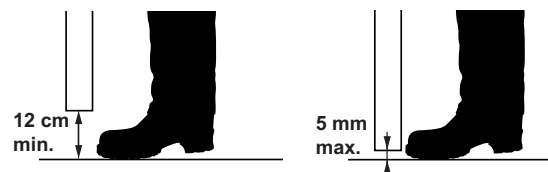

> Produktvorstellung

► Inhalt der Verpackung

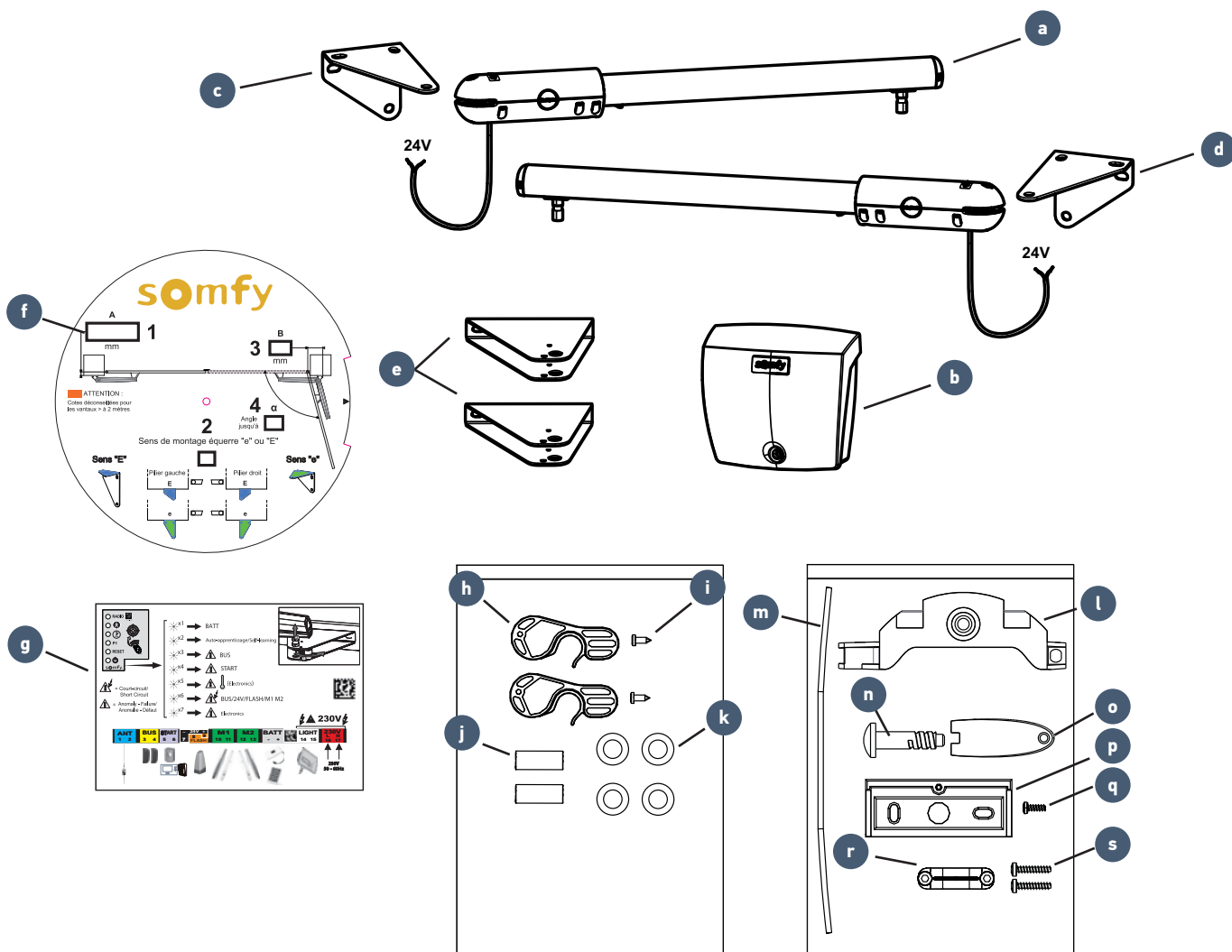

Pos.	Bezeichnung	Menge
a	Spindel 24 V	x2
b	Steuerkasten	x1
c	Befestigungswinkel Pfeiler/Mauer, links	x1
d	Befestigungswinkel Pfeiler/Mauer, rechts	x1
e	Befestigungswinkel Torflügel	x2
f	Scheibe zum Ermitteln der Maße	x1
g	Erinnerungsschild	x1
Beutel mit Zubehör für die Spindel		
h	Verriegelungsteil	x2
i	Schraube Verriegelungsteil	x2
j	Achse zur Befestigung der Spindel am Winkel für Pfeiler/Mauer	x2
k	Unterlegscheibe M8x22	x4

Pos.	Bezeichnung	Menge
Beutel mit Zubehör für den Steuerkasten		
l	Batteriehalterung	x1
m	Dichtungsband	x1
n	Schraube für Steuerkastenabdeckung	x1
o	Schlüssel zum Öffnen der Steuerkastenabdeckung	x1
p	Befestigungswinkel zur Wandbefestigung	x1
q	Schraube zur Befestigung des Steuerkastens am Befestigungswinkel	x1
r	Kabelzugentlastungsklemme	x1
s	Kabelklemmschrauben	x2

► Produktbeschreibung

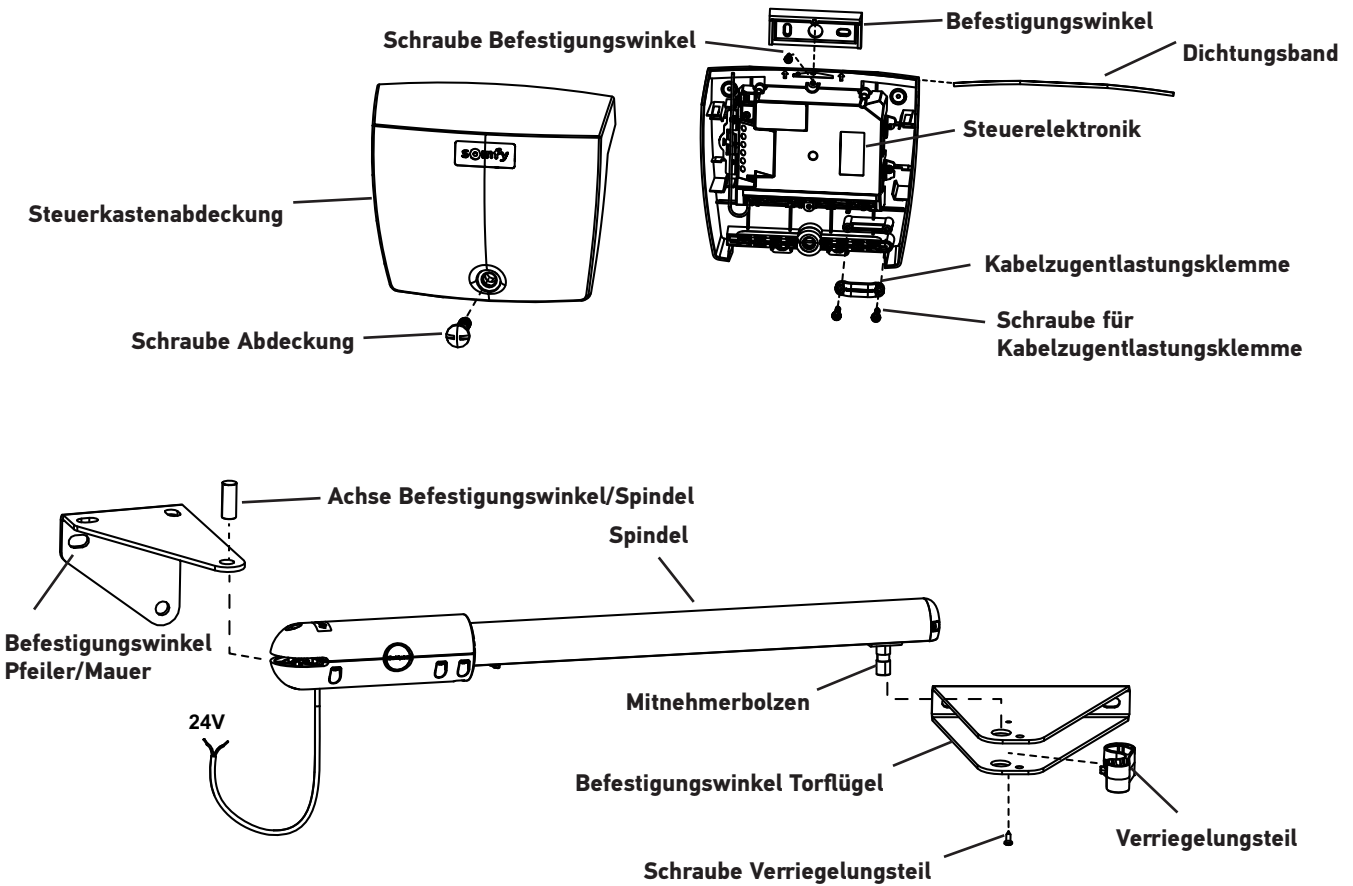

► Abmessungen

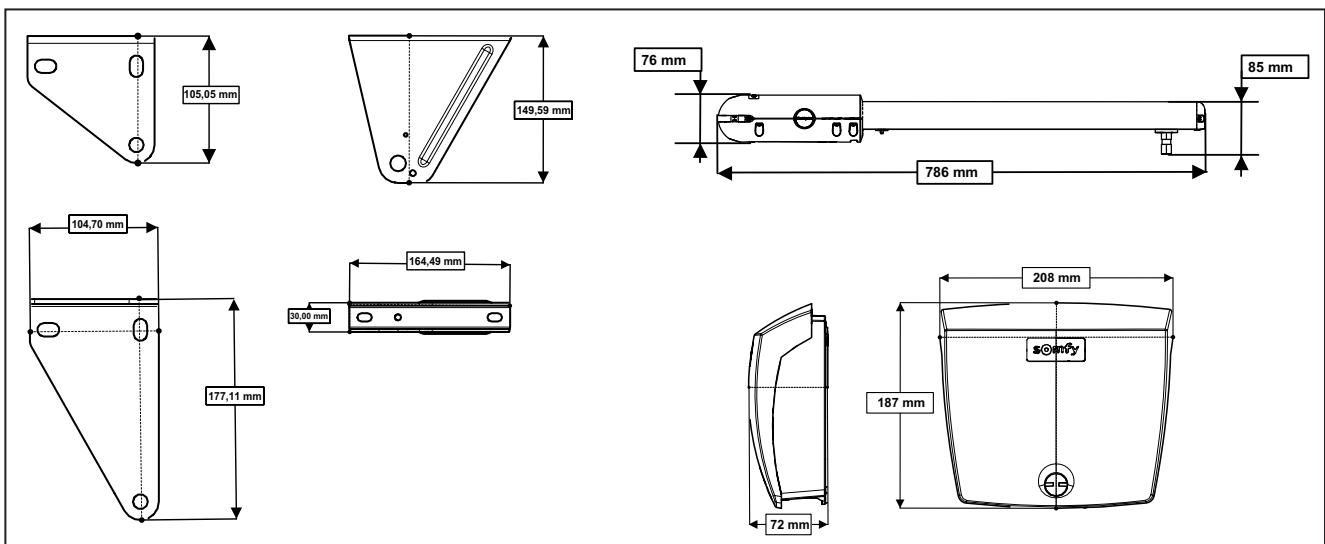

► Bestimmungsgemäße Verwendung

Diese Automatikvorrichtung wurde zum Antrieb von zweiflügeligen Toren für Privatgrundstücke entwickelt.

Maße und Gewicht der Torflügel

Max. Gewicht/Flügel (P)	200 kg
Max. Höhe/Flügel (H)	2 m
Min./max. Breite/Flügel (L)	1,25 / 2 m

In Abhängigkeit vom Typ des Tors (mit oder ohne Durchbrüche) und den Witterungsbedingungen (starker Wind) müssen diese Höchstwerte möglicherweise nach unten korrigiert werden (siehe nachstehende Tabelle).

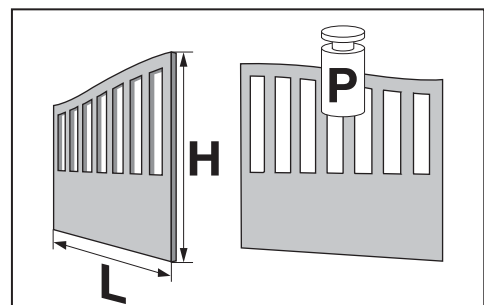

Maße und Gewicht der mit dem Antrieb zu bewegenden Torflügel in Abhängigkeit von der Windstärke

Windstärke	Wirkung	Produkt	SGS LINE
≥ 80 km/h	Gehen gegen den Wind ist unmöglich.		Min./max. Breite Max. Gewicht 1,25 / 1,5 m 200 kg
< 80 km/h > 40 km/h	Äste der Bäume werden bewegt.		Min./max. Breite Max. Gewicht 1,25 / 2 m 200 kg
			Min./max. Breite Max. Gewicht 1,25 / 1,5 m 200 kg
≤ 40 km/h	Sand wird aufgewirbelt.		Min./max. Breite Max. Gewicht 1,25 / 2 m 200 kg
			
			

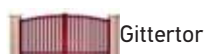

Gittertor



Teilweise vergittertes Tor



Geschlossenes Tor

► Übersicht über die Anlage

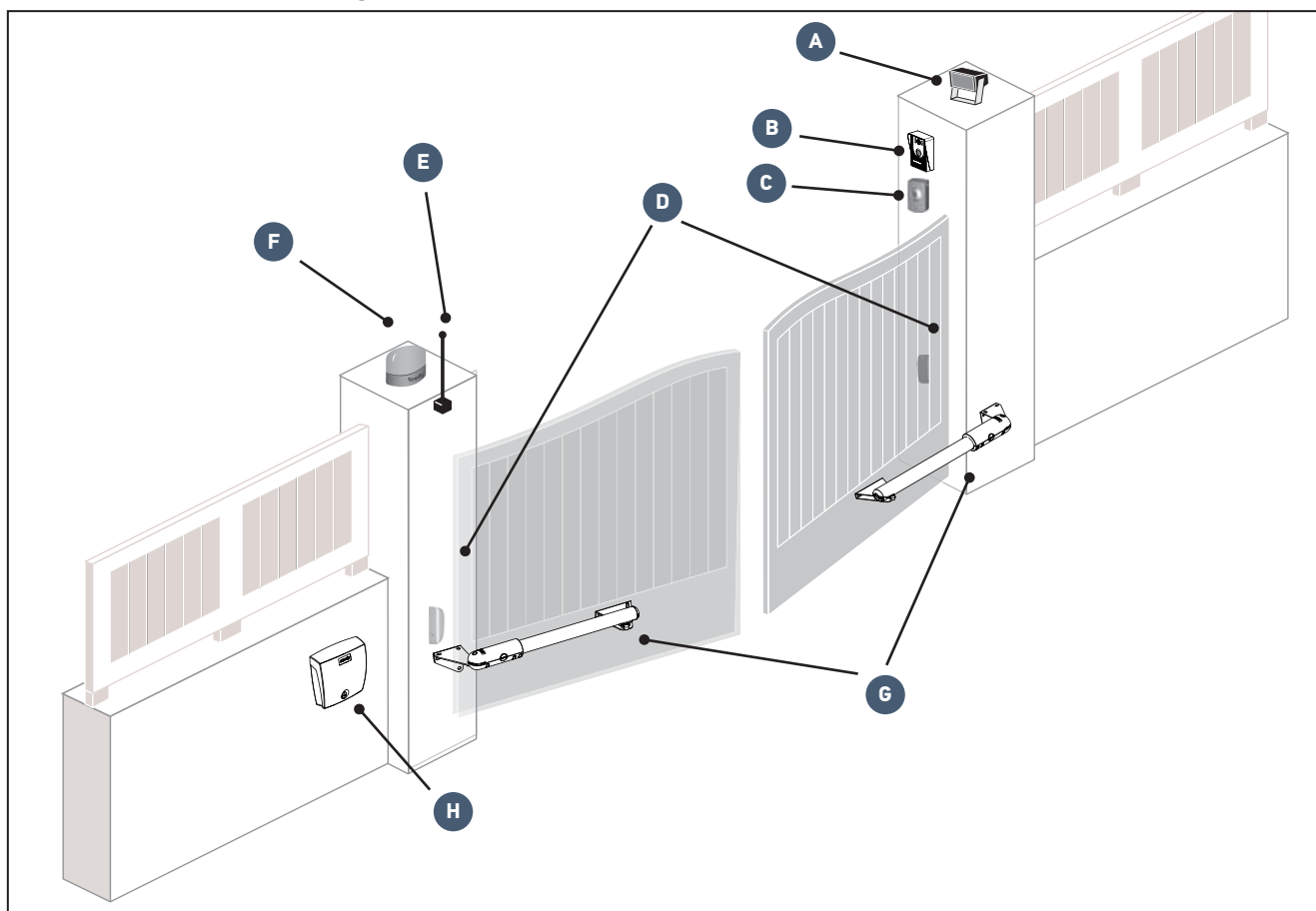

Position	Bezeichnung
A	Umfeldbeleuchtung*
B	Video-Türsprechanlage*
C	Schlüsselschalter*
D	Fotozellen

Position	Bezeichnung
E	Externe Zusatzantenne*
F	Signalleuchte
G	Antriebe
H	Steuerkasten

*Optionales Zubehör

► Übersicht über die Steuerelektronik

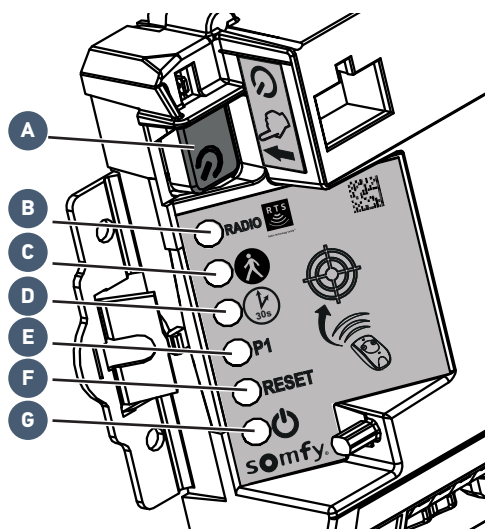

Pos.	Bezeichnung	Funktion	
A	Taste	Wechsel der Steuerelektronik in den Betriebsmodus	
B	LED FUNK	Leuchtet auf, wenn die Steuerelektronik einen Funkbefehl erhält	
C	LED	Leuchtet bei Aktivierung/Deaktivierung der Fußgängeröffnung auf	
D	LED	Ein	Der automatische Zulauf des Tors ist aktiviert.
		Aus	Der automatische Zulauf des Tors ist nicht aktiviert.
		Blinkt	Der Parameter „Automatischer Zulauf“ ist ausgewählt.
E	LED P1	Nicht belegt	
F	LED RESET	Ein	Es werden entweder nur die Einstellungen oder die Einstellungen und die Funksender gelöscht.
		Blinkt	Die Funktion zum Löschen der Einstellungen und der Funksender ist ausgewählt.
G	LED	Ein	Der Antrieb funktioniert ordnungsgemäß – die Steuerelektronik ist im Betriebsmodus.
		Aus	Der Antrieb funktioniert ordnungsgemäß – die Steuerelektronik ist im Standbymodus.
		Blinkt	siehe „Diagnose“, Seite 31

► Voraussetzungen für die Installation

► Vor der Montage zu prüfende Punkte

Tor

Das Tor ist in gutem Zustand: Es lässt sich ohne übermäßigen Kraftaufwand öffnen und schließen. Es bleibt auf seinem gesamten Weg horizontal. Es öffnet auf das Grundstück.

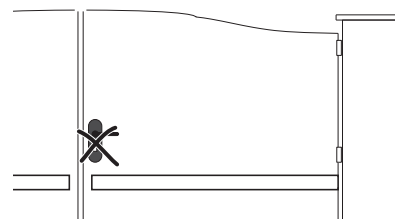
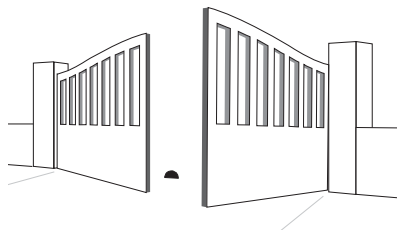
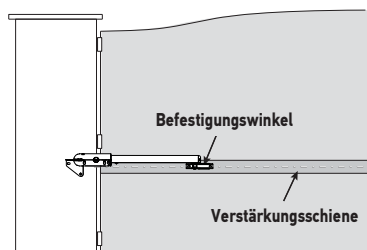

Verstärkungsschienen

Diese Antriebe müssen an den horizontalen Verstärkungen der Torflügel befestigt werden, die sich im Idealfall auf einem Drittel der Höhe des Tors befinden. Wenn keine Verstärkungen vorhanden sind, müssen Montageplatten aus Metall mit einer Stärke von ca. 4 mm angebracht werden.

Schließanschläge am Boden

Der Schließweg des Tors muss von Anschlägen begrenzt werden, die fest am Boden verankert sind. Die Öffnungsanschläge sind im Antrieb integriert (siehe „Einstellung des Öffnungsanschlags“, Seite 19).

Mechanisches Schloss

Wenn das Tor mit einem mechanischen Schloss ausgerüstet ist, muss dieses entfernt werden.

Pfeiler

Die Pfeiler müssen standfest und mindestens 21 cm breit sein. Ist dies nicht der Fall, sind für eine ordnungsgemäße Montage und einen guten Halt des Befestigungswinkels unter Umständen besondere Maßnahmen erforderlich. Es wird davon abgeraten, den Winkel bündig mit der Pfeilerkante zu montieren: Die Kante könnte abplatzen.

► Elektrische Vorbereitung

Bereitzustellende Kabel

- Netzstromversorgung: Kabel $3 \times 1,5 \text{ mm}^2$ oder $3 \times 2,5 \text{ mm}^2$ zur Installation im Außenbereich (min. Typ H07RN-F).
- Verbindung zwischen den beiden Motoren: Kabel $2 \times 1 \text{ mm}^2$; einen IP55-Schaltkasten zum Schutz der Verbindung zwischen dem Kabelausgang am Antrieb und der Verlängerung vorsehen, die zum Steuerkasten verläuft.
- Anschluss der Fotozellen: Kabel $2 \times 0,75 \text{ mm}^2$.



Sehen Sie einen Kabelkanal für das Netzstromkabel vor. Beachten Sie dabei die in Ihrem Land geltenden elektrischen Normen.

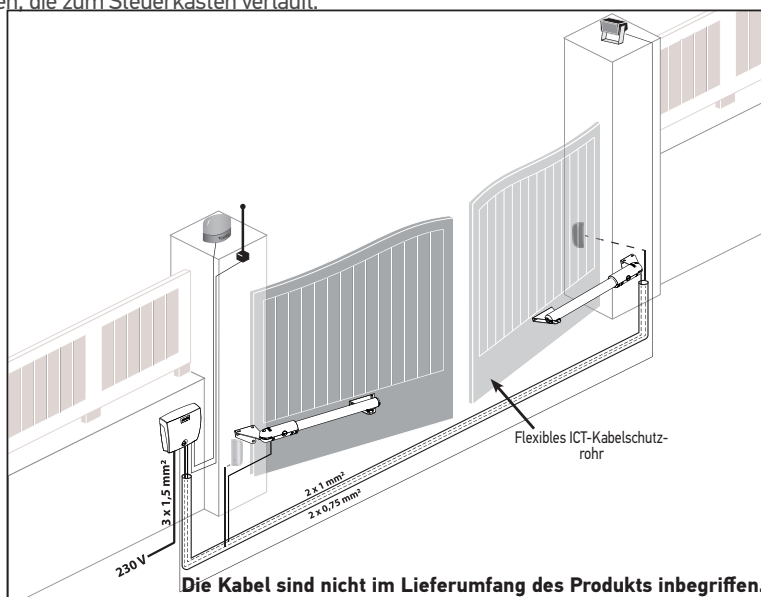
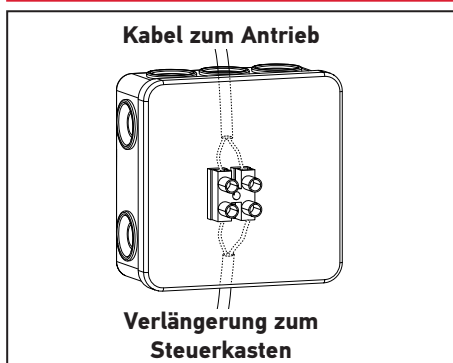

Kabelführung

- In der Erde verlegte Kabel müssen in einem Schutzrohr verlegt werden, dessen Durchmesser groß genug ist, um alle Kabel aufnehmen zu können.
- Eine 230-V-Leitung so nahe wie möglich zum Montageort des Steuerkastens verlegen.

► Bereitzustellende Kabel



Näheres zur Verkabelung siehe „Verkabelung des Zubehörs“, Seite 22.



Wenn die Verlegung im Erdreich nicht möglich ist, sollten Sie einen Kabelkanal verwenden, der für das Überfahren mit Fahrzeugen geeignet ist (Teile-Nr. 2400484).

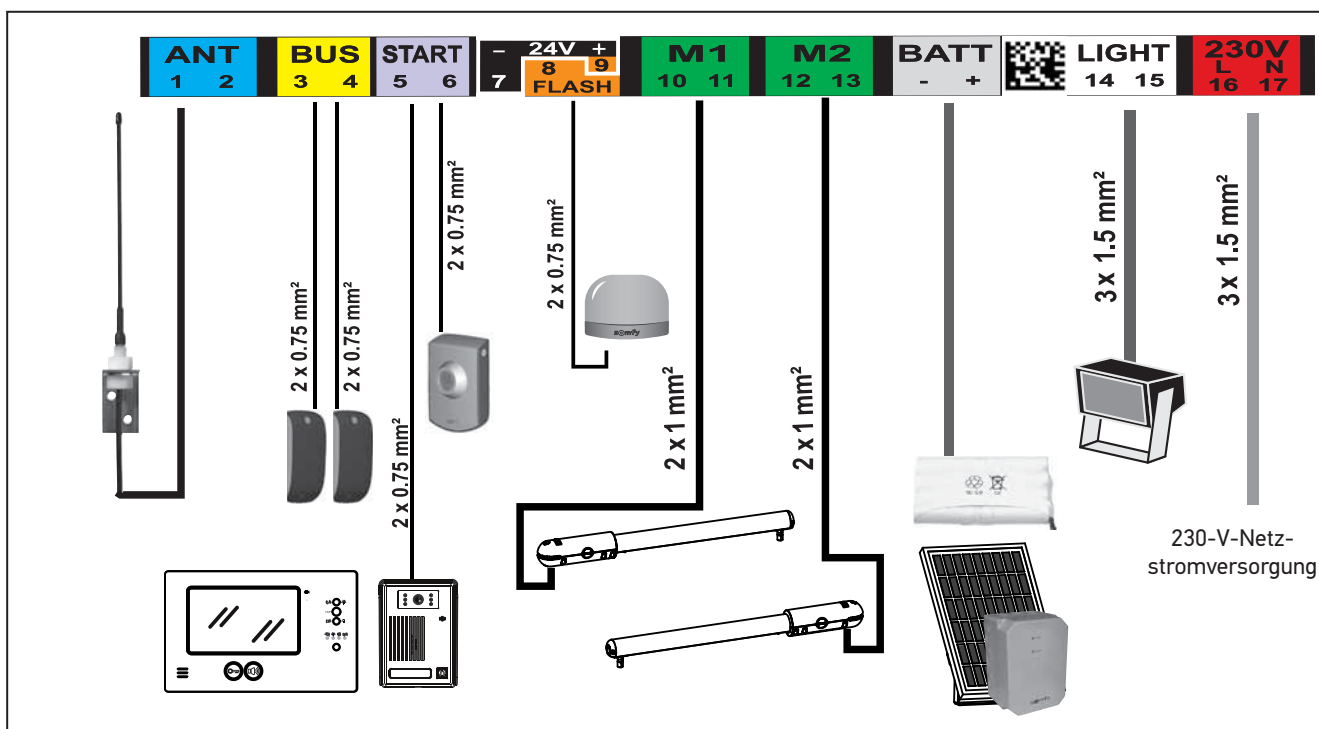

► Für die Installation benötigtes Werkzeug (nicht im Lieferumfang)

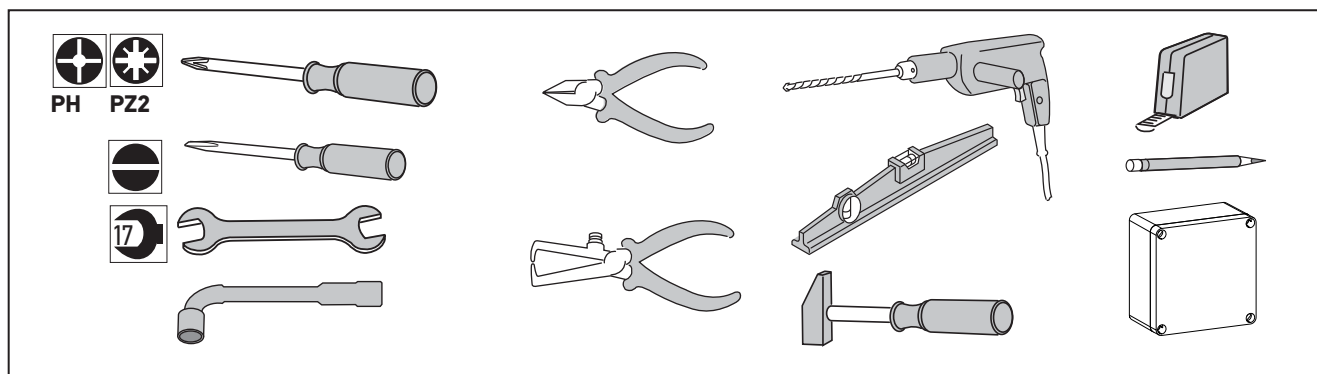

► Für die Installation benötigte Verbindungsmittel (nicht im Lieferumfang)

Diese Angaben sind unverbindlich.

Zur Befestigung von...	Menge	
BEFESTIGUNGSWINKELN AN DEN PFEILERN/MAUERN		
	Schrauben , die für das Material von Pfeiler/Mauer geeignet sind (Schrauben, Stifte, Zement...): - Durchmesser: 8 bis 10 mm - Sechskantkopf	6
	Unterlegscheiben: - Innendurchmesser: 8 bis 10 mm - Außendurchmesser: 16 bis 20 mm	6
	Muttern: - Durchmesser: 17 mm	
BEFESTIGUNGSWINKELN AN DEN TORFLÜGELN		
	Schrauben , die für das Material der Verstärkungsschienen der Torflügel geeignet sind: - Durchmesser: 8 mm - für die Dicke der Verstärkungsschienen der Torflügel geeignete Länge	6
	Mitgelieferte Unterlegscheiben - Innendurchmesser: 8 mm - Außendurchmesser: 22 mm	6
STEUERKASTEN		
	Schrauben , die für das Material von Pfeiler/Mauer geeignet sind - Schraubendurchmesser: 3,5 bis 4,5 mm - Senk- oder Flachrundschrauben - Dübel Typ „S“ für Beton: S5, S6 oder S8	4

1.1 Ermittlung der Maße

Mit der Scheibe (f) die Maße für die Position der Antriebe an den Pfeilern feststellen.

Hinweis: Bei den Maßen wird davon ausgegangen, dass Flügel und Angeln in einer Ebene liegen.

Erinnerung: Zwischen den Torflügeln und den feststehenden Bestandteilen der Toranlage mindestens 50 cm Abstand halten (siehe „Gefahrenvermeidung“, Seite 4).

1 Maß A abmessen.

Das gemessene Maß A auf die Scheibe übertragen.

ACHTUNG
Maße > 2 Meter für Torflügel nicht empfohlen

3 Maß B ermitteln.

2 Die Montagerichtung (e oder E) der Befestigungswinkel für die Spindeln am Pfeiler wird angegeben.

Montagerichtung Befestigungswinkel „e“ oder „E“

Richtung „E“ Linker Pfeiler Rechter Pfeiler Richtung „e“

Sens „E“ Sens „e“

Pilier gauche Pilier droit

ATTENTION :
Cotes déconseillées pour les vantaux > à 2 mètres

Angle jusqu'à

4 Der maximale Öffnungswinkel α ist angegeben.

Winkel bis

! Die über die Scheibe gewonnenen Vorgaben bzgl. des maximalen Öffnungswinkels unbedingt einhalten.

i **Empfehlung: Maß A ist negativ.**

Wenn das Maß A negativ ist, befindet sich das Torscharnier vor dem Pfeiler. Wir empfehlen die Nutzung eines Einsatzes, der dafür sorgt, dass der Befestigungswinkel der Spindel sich auf der Achse des Torscharniers befindet und Maß A gleich 0 cm ist.

1.2 Befestigung der Pfeilerbefestigungswinkel

► Anzeichnen der Achsen AM und AH

1. Das Maß B auf dem Pfeiler ab der Scharnierachse markieren und eine vertikale Achse AM auf dem Pfeiler anzeichnen.
2. In Höhe der Mitte der Verstärkungsschiene die horizontale Achse AH am Pfeiler anzeichnen.



Nachkontrolle vor dem nächsten Schritt
Haben Sie die Achsen AM und AH korrekt angezeichnet?

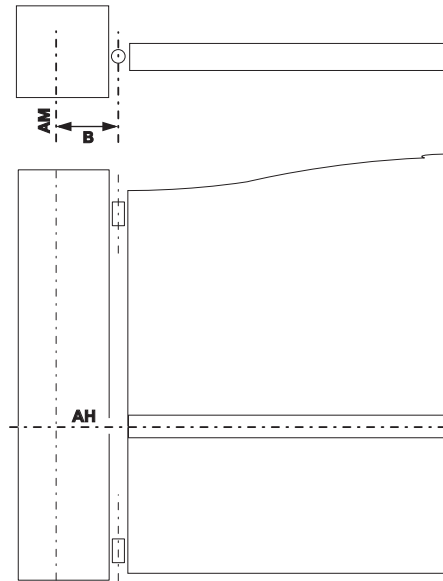

► Herstellen der Bohrungen an den Pfeilern

1

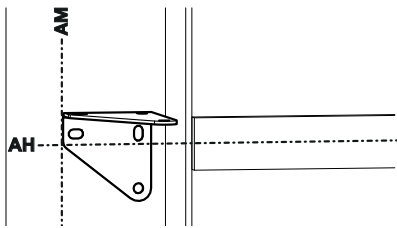

Die Markierungen auf dem Winkel mit der Achse AH in eine Flucht bringen und den Rand des Winkels an der Achse AM ausrichten.

Hinweis: Die am Winkel angezeichneten Markierungen müssen durch die Langlöcher sichtbar sein.



Den Winkel in der Montagerichtung e bzw. E positionieren, wie in Schritt 2 der Ermittlung der Maße ermittelt (siehe Seite

Linker Pfeiler

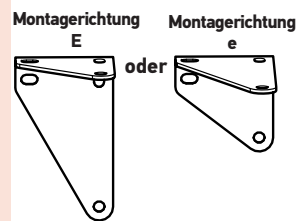

Rechter Pfeiler

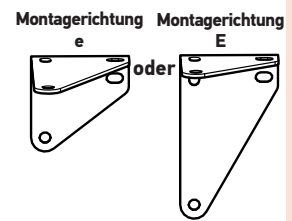

Oben und unten am Befestigungswinkel auf die Montagerichtung achten.

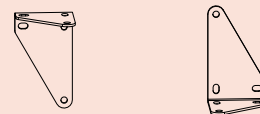

Korrekte Richtung Falsche Richtung

2

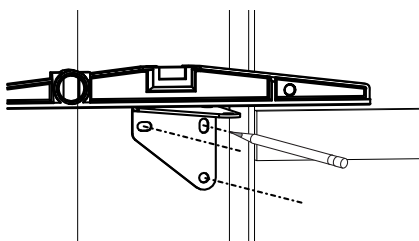

Darauf achten, dass der Winkel horizontal ist, und dann die Befestigungslöcher des Winkels markieren.

3

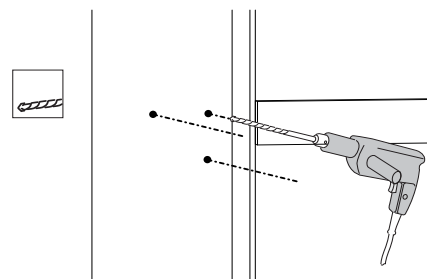

An den markierten Stellen 3 Löcher in jeden Pfeiler bohren (siehe Seite 11 für Informationen zum Bohrdurchmesser für die entsprechenden Schrauben).

► Anbringung des Befestigungswinkels am Pfeiler

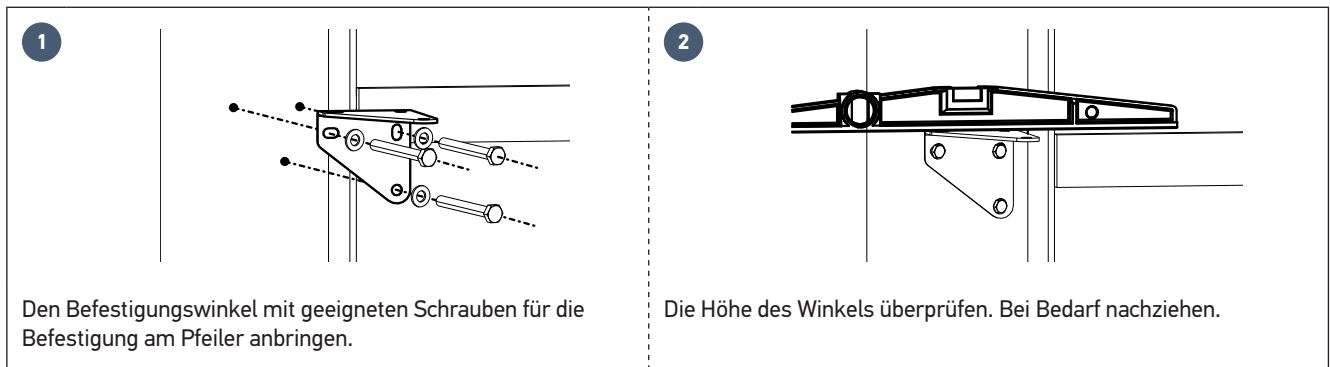

Nachkontrolle vor dem nächsten Schritt
Haben Sie geprüft, ob die Winkel genau horizontal sitzen?

► Anbringen der Spindel am Befestigungswinkel

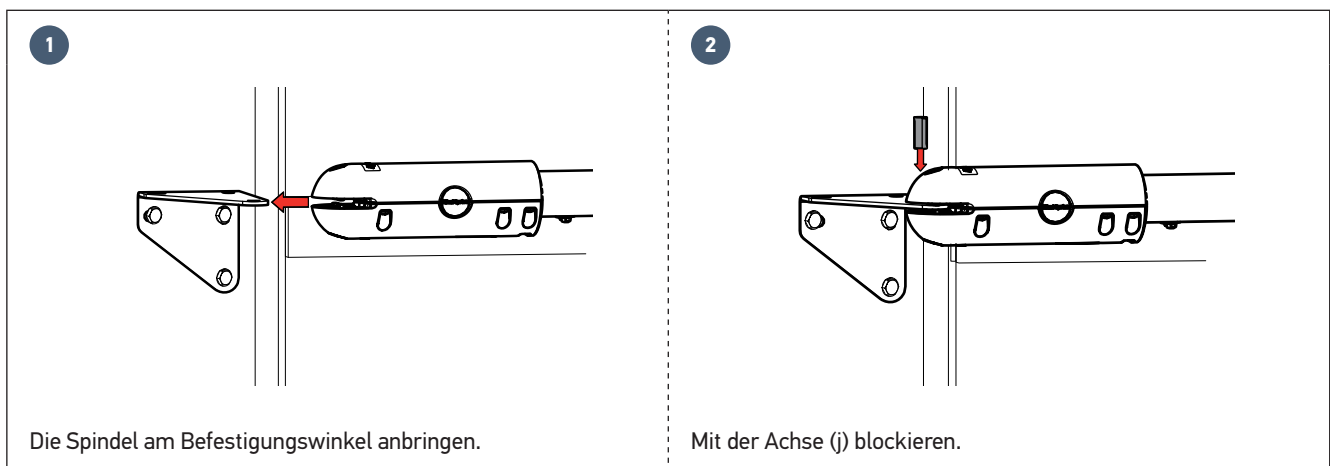

1.3 Befestigung der Antriebe an den Torflügeln



Die Spindel nie in Betrieb nehmen, bevor die Befestigung am Flügel ganz abgeschlossen ist. Andernfalls wird die Einstellung der inneren Anschläge verstellt und Fehlfunktionen können die Folge sein.

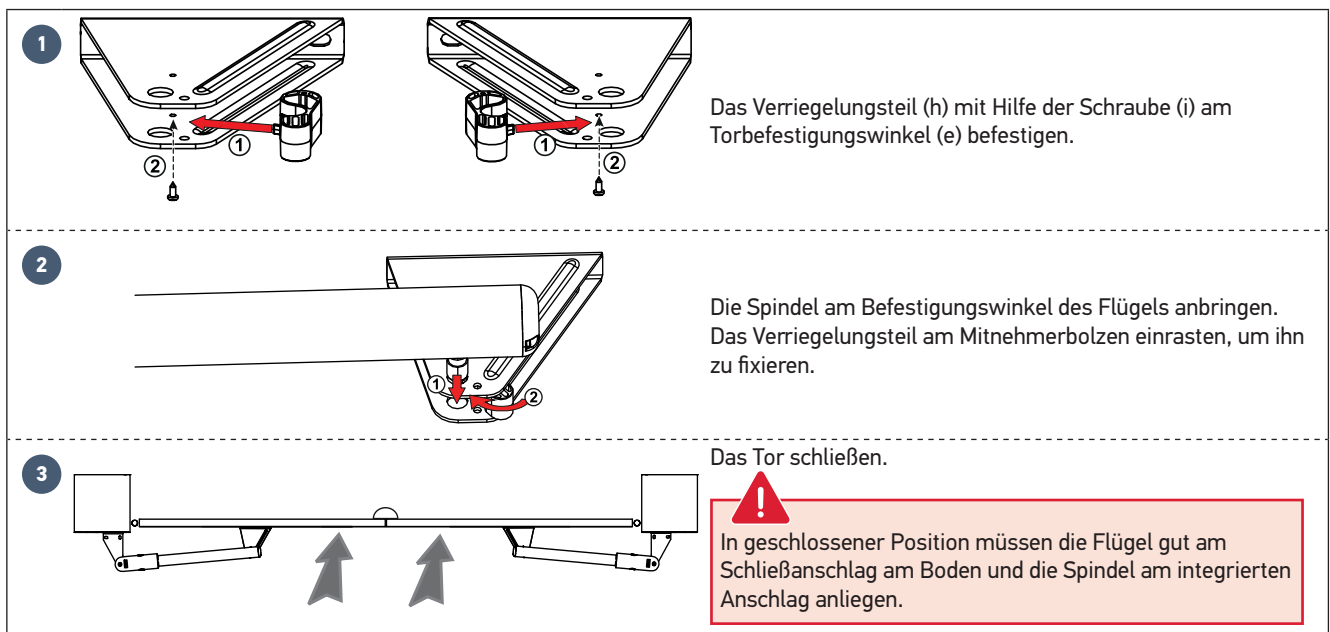

4

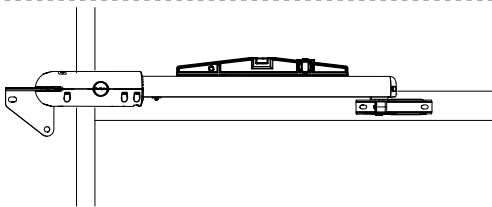

Den Befestigungswinkel für den Flügel an der Verstärkungsschiene der Flügel positionieren. Prüfen, ob die Spindel genau horizontal sitzt.

5

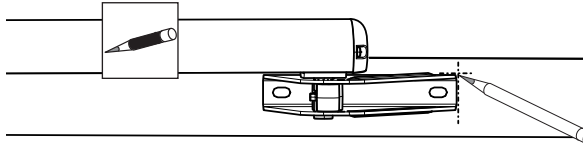

Die Seiten des Befestigungswinkels für die Flügel entsprechend markieren.

6

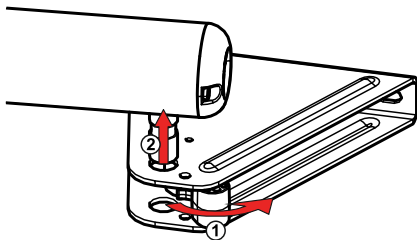

Das Verriegelungsteil ausrasten und die Spindel vom Spindelbefestigungswinkel abnehmen.

7

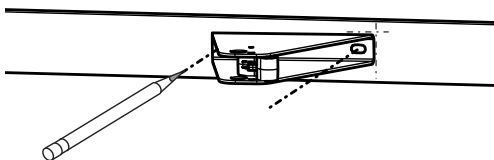

Den Befestigungswinkel des Flügels erneut in Position bringen und dann die Befestigungslöcher in der Mitte der Langlöcher markieren.

8

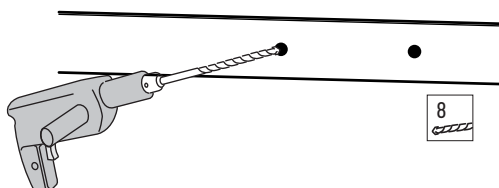

An beiden Flügeln Bohrungen mit Durchmesser 8 herstellen.

9

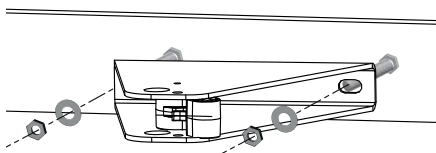

Den Torflügelbefestigungswinkel an den beiden Punkten an den Torflügeln befestigen. Hierfür Schrauben verwenden, die für das Material der Verstärkungsschienen geeignet sind, und die mitgelieferten Unterlegscheiben (k).



Die mitgelieferten Unterlegscheiben (k) sind auf jeden Fall zu montieren.

10

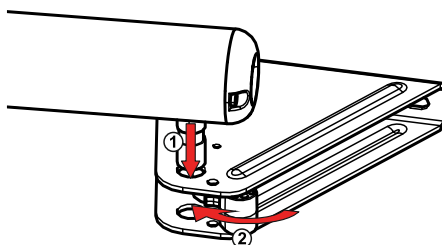

Die Spindel anbringen. Das Verriegelungsteil am Mitnehmerdorn einrasten, um ihn zu fixieren.



Nachkontrolle vor dem nächsten Schritt
Haben Sie überprüft, ob die Spindel ganz horizontal sitzt?

1.4 Installation des Steuerkastens

► Position des Steuerkastens

Das Gehäuse muss auf der Seite an der Wand oder einem Pfeiler angebracht werden, an der die Spannungsversorgung ankommt.

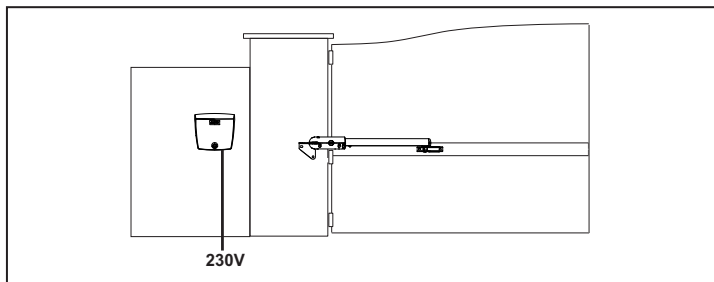

► Einlegen des Dichtungsbandes

Das Dichtungsband(m) oben in den Steuerkasten einlegen.

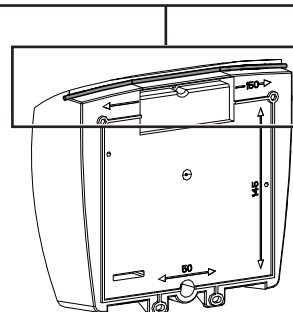
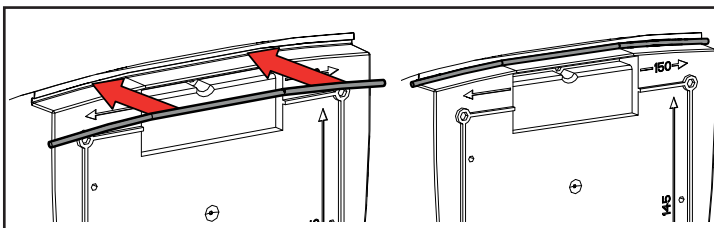

► Überprüfung der Position der Antenne

Damit die Antenne optimal funktioniert, muss sie korrekt ausgerichtet sein.



Den Antennendraht keinesfalls abschneiden.

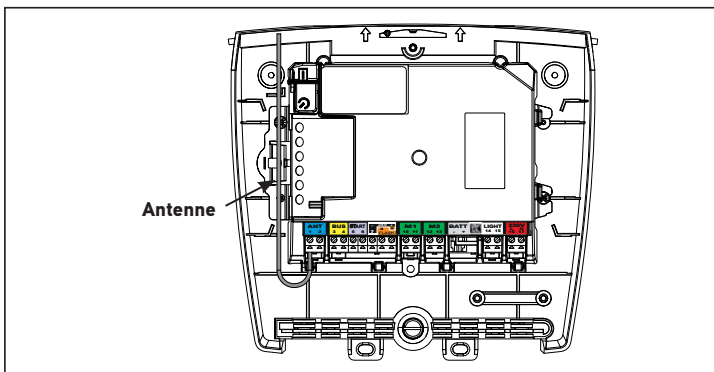

► Befestigung des Steuerkastens

<p>1</p>	<ul style="list-style-type: none"> • Den Befestigungswinkel des Steuerkastens (p) am Pfeiler/ an der Mauer positionieren. • Die horizontale Position überprüfen, indem Sie an der vorgesehenen Position mit der Wasserwaage nachmessen. • Die Befestigungspunkte des Befestigungswinkels markieren.
<p>2</p>	<p>Den Befestigungswinkel entfernen und die Löcher in Pfeiler/ Mauer bohren. Der Bohrdurchmesser ist von dem für die Befestigung verwendeten Schraubentyp abhängig (siehe Seite 11).</p>

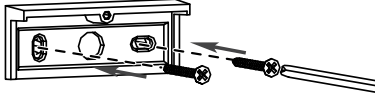
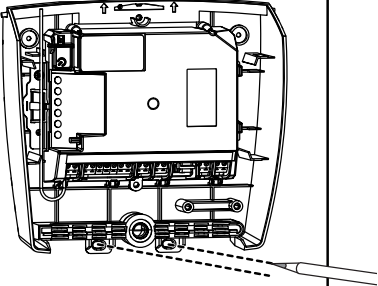
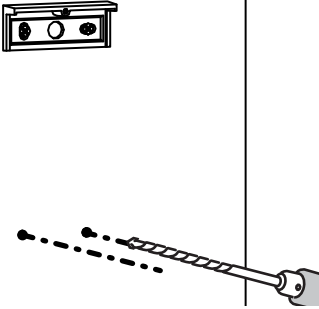
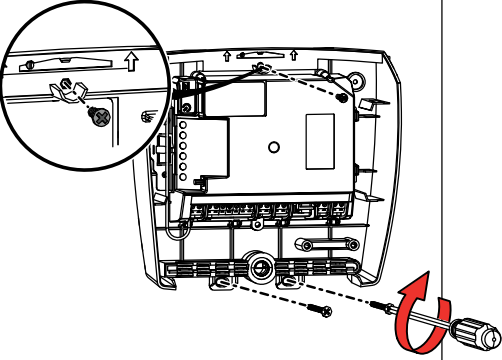
<p>3</p>		<p>Den Befestigungswinkel an Pfeiler/Mauer anbringen.</p>
<p>4</p>		<p>Das Unterteil des Steuerkastens anbringen, um die 2 Befestigungspunkte unten am Steuerkasten zu markieren.</p>
<p>5</p>		<p>Das Unterteil des Steuerkastens entfernen und dann die Löcher in Pfeiler/Mauer bohren. Der Bohrdurchmesser ist von dem für die Befestigung verwendeten Schraubentyp abhängig (siehe Seite 11).</p>
<p>6</p>		<p>Das Unterteil des Steuerkastens an Pfeiler/Mauer anbringen: 1 Schraube (q) zur Befestigung des Kastens am Winkel und + 2 Schrauben zur Befestigung des Kastens an Pfeiler/Mauer.</p>

1.5 Anschluss der Antriebe



Der Antrieb M1 bewegt den Torflügel, der:

- sich zuerst öffnet und als letzter schließt,
- als Fußgängeröffnung dient.

1

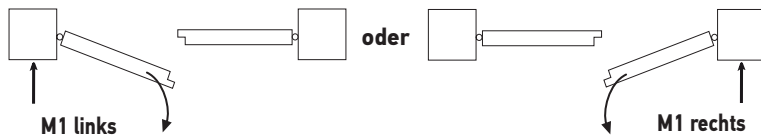

Bei geschlossenem Tor festlegen, welcher Torflügel sich zuerst öffnen soll. Dieser Torflügel wird von Antrieb M1 bewegt.

2

Die Antriebe entsprechend den Angaben in untenstehender Tabelle anschließen.

Das Kabel des Antriebs anschließen ...		an Klemme ...
M1	Blau	10
	Braun	11
M2	Blau	12
	Braun	13

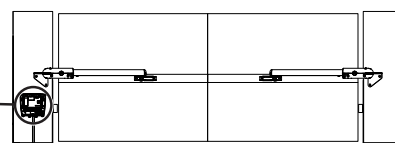
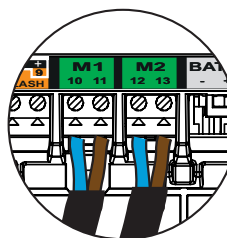

1.6 Anschluss an die Netzstromversorgung



Führen Sie die folgenden Arbeiten zu Ihrer eigenen Sicherheit nur bei nicht angeschlossener Stromversorgung aus. Verwenden Sie ein Kabel 3 x 1,5 mm² zur Installation im Außenbereich (min. Typ H07RN-F). Verwenden Sie unbedingt die mitgelieferte Kabelzugentlastungsklemme. Für alle Niederspannungskabel sicherstellen, dass sie einer Zugbelastung von 100 N standhalten. Sicherstellen, dass die Leiter bei Anwendung dieser Zugbelastung nicht bewegt werden.

1

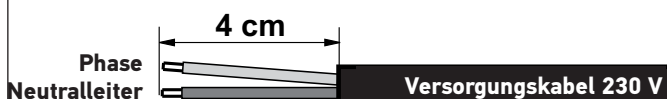

An einem 3 x 1,5 mm²-Kabel, 2 Drähte von 4 cm vorbereiten (Phase und Neutralleiter).

2

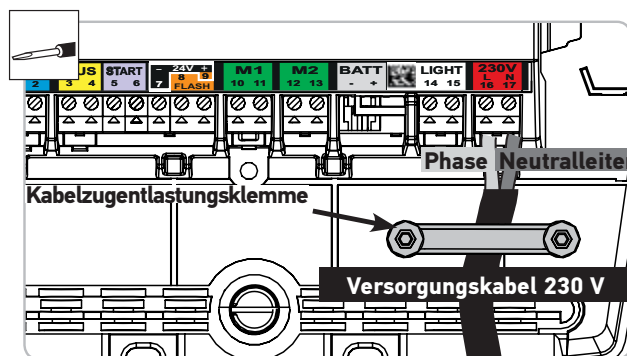

- Phase und Neutralleiter an den Klemmen 16 und 17 anschließen (rotes Schild „230 V“).
- Das Versorgungskabel 230 V mit der mitgelieferten Kabelzugentlastungsklemme (r) fixieren.
- Eine Lüsterklemme am Erdungskabel (grün/gelb) befestigen und diese im Steuerkasten unterbringen.

2.1 Einschalten der Anlage

Die LED  blinkt (2 Mal).

Der Antrieb ist an die Spannungsversorgung angeschlossen und auf das automatische Einlernen vorbereitet.

Leuchtet die LED  nicht auf oder blinkt sie nicht so häufig, wie erwartet: siehe „Diagnose“, Seite 31.

2.2 Einstellung des Öffnungsanschlags



Öffnungsanschläge

Die Öffnungsanschläge sind in die Spindel integriert. Sie begrenzen den Weg des Tors beim Öffnen.

Erinnerung: Die Anlage muss am Boden befestigte Schließanschläge besitzen, um den Weg des Tors beim Schließen zu begrenzen.

Während dieser Phase führt die Betätigung der Taste 1 auf dem programmierten Funksender nur zum Öffnen und Anhalten des Tores (1. Betätigung = Öffnen, 2. Betätigung = Stopp, 3. Betätigung = Öffnen, 4. Betätigung = Stopp etc.): So lässt sich in mehreren Schritten die gewünschte Öffnungsposition regeln. Das Tor kann geschlossen werden, sobald die Öffnungsanschläge installiert sind.

1

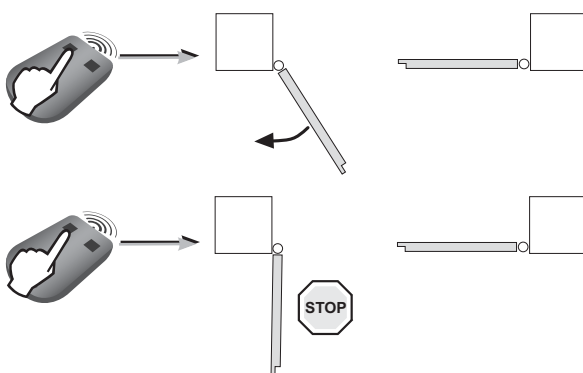

- Taste 1 des Funksenders drücken.
Nach einigen Sekunden öffnet sich der erste Torflügel langsam.
Wenn sich der Torflügel nicht öffnet, überprüfen, ob die Antriebe wie auf Seite 18 angegeben verkabelt sind.
- Erneut die Taste 1 des Funksenders betätigen, um den Torflügel in der gewünschten Öffnungsposition anzuhalten.

2

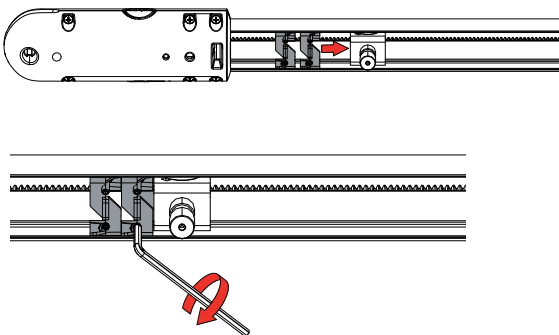

Die Öffnungsanschläge in Kontakt mit der Spindelkettennuss positionieren und dann die Anschläge mit einem Innensechskantschlüssel mit 3 mm Durchmesser festziehen (2 Schrauben pro Anschlag).



Nach dem Kontakt 2 Umdrehungen mit dem Schlüssel ausführen.

3

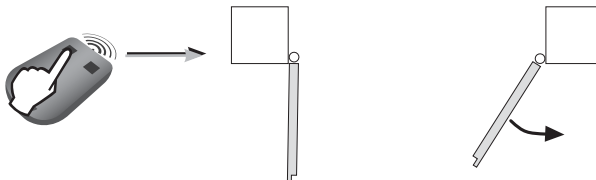

Taste 1 des Funksenders drücken.
Der zweite Torflügel öffnet sich.

4

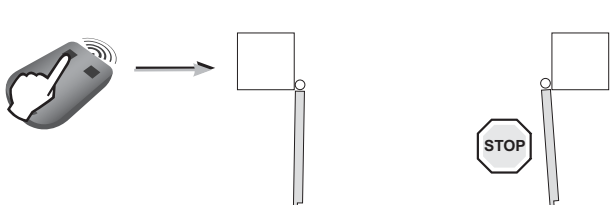

Erneut die Taste 1 des Funksenders betätigen, um den Torflügel in der gewünschten Öffnungsposition anzuhalten.

5

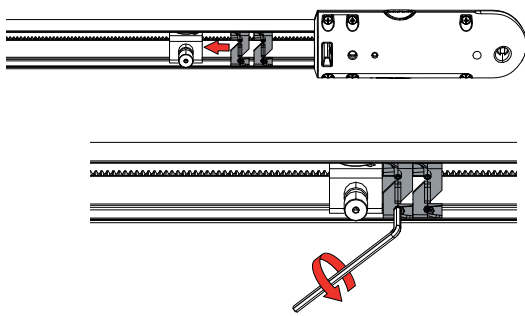

Die Öffnungsanschlüge in Kontakt mit der Spindelkettennuss positionieren und dann die Anschläge mit einem Innensechskantschlüssel mit 3 mm Durchmesser festziehen (2 Schrauben pro Anschlag).

! Nach dem Kontakt 2 Umdrehungen mit dem Schlüssel ausführen.

6

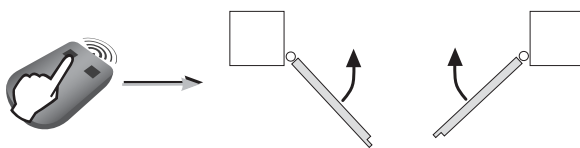

Taste 1 des Funksenders drücken, um das Tor vollständig zu schließen. Die Flügel schließen sich nacheinander.

Nachkontrolle vor dem nächsten Schritt
Haben Sie die Position des Öffnungsanschlags für beide Antriebe eingestellt?

2.3 Selbsteinlernfunktion für den Torweg

Überprüfen, ob die Anlage an die Spannungsversorgung angeschlossen ist: Die LED blinkt (2 Mal).

Fall 1: Erstinbetriebnahme des Antriebs

Taste 1 des Funksenders drücken, um einen VOLLSTÄNDIGEN Öffnungsvorgang auszulösen.

Wenn das Tor vollständig geöffnet ist, erneut Taste 1 des Funksenders drücken, um einen VOLLSTÄNDIGEN Schließvorgang auszulösen.

Wenn das Tor vollständig geschlossen ist, muss die LED des Steuerkastens DURCHGEHEND LEUCHTEN.

Fall 2: Nach dem Löschen von Einstellungen

4 Vollöffnungen und Schließungen des Tors durchführen.

Bei Ende der 4 Bewegungen muss die LED des Steuerkastens DURCHGEHEND LEUCHTEN.

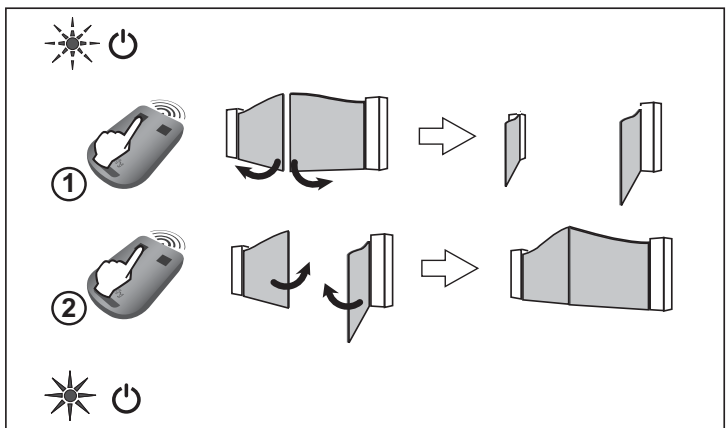

! Die Bewegungen des Tors dürfen nicht unterbrochen werden (vollständiges Öffnen/Schließen). Sollten sie unterbrochen werden, beginnt das Einlernen automatisch beim nächsten Öffnungsbefehl.

Wenn die LED blinkt, das automatische Einlernen der Torflügelwege erneut durchführen (4 vollständige Öffnungs-/Schließbewegungen). Falls die LED weiter blinkt, finden Sie Hilfe im Abschnitt „Diagnose“, Seite 31.

Wenn sich das Tor nach Abschluss des Schließvorgangs wieder öffnet, die Befestigungswinkel der Torflügel lösen und etwas zur Mitte des Tores verschieben.

!
WARNUNG
 Nach Abschluss der Montage muss unbedingt überprüft werden, ob die Hinderniserkennung die Anforderungen des Anhangs A der Norm EN 12 453 erfüllt.

2.4 Schließen des Steuerkastens

1

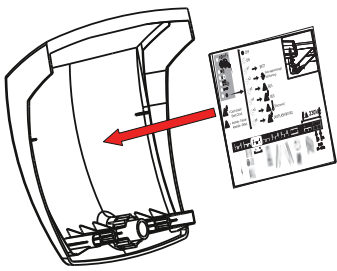

Das Erinnerungsschild (g) unten am Steuerkasten anbringen.

2

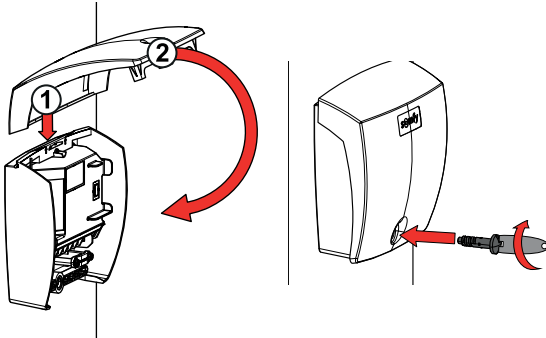

Den Steuerkasten schließen und die Abdeckung verschrauben.

2.5 Wechsel der Steuerelektronik in den Standby-/Betriebsmodus



Wenn das automatische Einlernen durchgeführt wurde, schaltet die Steuerelektronik automatisch nach 5 Minuten Inaktivität in den Standbymodus, um Energie zu sparen. Im Standbymodus sind alle LEDs ausgeschaltet.

Um festzustellen, ob der Antrieb unter Spannung ist, oder um die Einstellungen zu überprüfen/ändern, 2 Sekunden lang die Taste  betätigen, um die Steuerelektronik in den Betriebsmodus zu versetzen. Die Steuerelektronik schaltet nach 5 Minuten Inaktivität automatisch in den Standbymodus.

2.6 Vollöffnung und Schließung des Tors



Die mit dem Kit gelieferten Funksender sind bereits eingelernt und so programmiert, dass die Taste 1 der Funksender die Vollöffnung des Tors bewirkt.



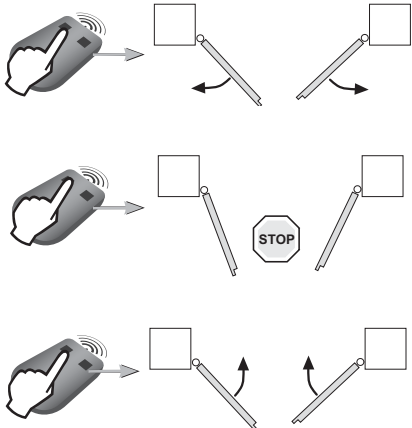

- Bei geschlossenem Tor: Drücken Sie die Taste 1 des Funksenders, um das Tor ganz zu öffnen.
- Während sich das Tor bewegt: Drücken Sie die Taste 1 des Funksenders, um das Tor anzuhalten.
- Bei offenem Tor: Drücken Sie die Taste 1 des Funksenders, um das Tor zu schließen.

2.7 Hinderniserkennung

Wenn ein Hindernis erkannt wird (ungewöhnlicher Kraftaufwand am Antrieb) :

- **Beim Öffnen des Tors:** hält das Tor an.
- **Beim Schließen des Tors:** hält das Tor an und öffnet dann erneut.

2.8 Schulung der Benutzer

Alle Benutzer müssen in die sichere Verwendung dieses elektrisch angetriebenen Tores eingewiesen werden (Standardbenutzung und Entriegelungsprozeduren). Zudem müssen sie über die regelmäßigen Pflichtprüfungen informiert werden.



Führen Sie die folgenden Arbeiten zu Ihrer eigenen Sicherheit nur bei nicht angeschlossener Stromversorgung aus.



Es wird empfohlen, den Torweg automatisch einzulernen, bevor das Zubehör angeschlossen wird (Lichtschanke, Signalleuchte etc.).

3.1 Fotozellen



Die Verkabelung eines zweiten Fotozellensatzes ist bei diesem Antrieb nicht möglich.

► Installation

Nach Verkabelung der Lichtschanke:

- Schalten Sie die Stromversorgung des Antriebs erneut ein.
- Führen Sie eine Öffnungs- und Schließbewegung des Tors aus.

Die Fotozellen werden von der Steuerelektronik beim Ende der Bewegung erkannt.

► Funktion der Fotozellen

Wenn die Fotozellen beim Schließen des Tors verdeckt werden, bleibt das Tor stehen und öffnet erneut.

► Wenn Fotozellen entfernt werden

Nach Entfernung der Lichtschanke die Stromversorgung zum Antrieb wiederherstellen und dann das Verfahren „Deaktivierung des automatischen Zulaufs“, Seite 26, durchführen.

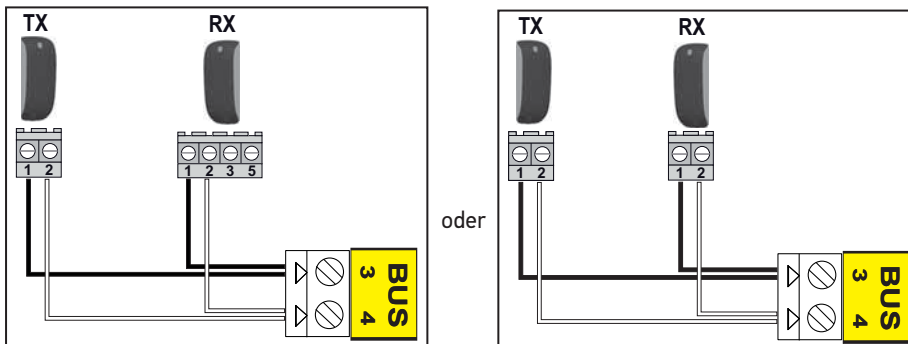

3.2 Signalleuchte



Leuchtmittel 10 W - 24 V MAX. – Die Verwendung eines Leuchtmittels mit mehr als 10 W - 24 V Leistung kann zu Funktionsstörungen Ihres Antriebs führen.

► Funktion der Signalleuchte

Die Signalleuchte blinkt, während das Tor sich bewegt.

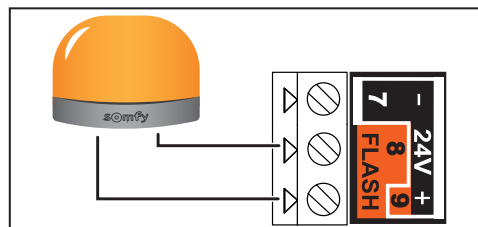

3.3 Batterie (Option)



Dieses Zubehör ist mit einer Solarstromversorgung nicht kompatibel.



Um die Nutzungsdauer der Batterie zu verlängern, werden alle per Kabel angeschlossenen Zubehörteile deaktiviert; das Tor kann nur mit den Funksendern oder Funktastaturen betätigt werden.

Die Notstrombatterie ermöglicht einen Weiterbetrieb des Tors, wenn der Strom ausfällt.

Die LED blinkt (1 Impuls), wenn der Antrieb mit Batteriestrom arbeitet.

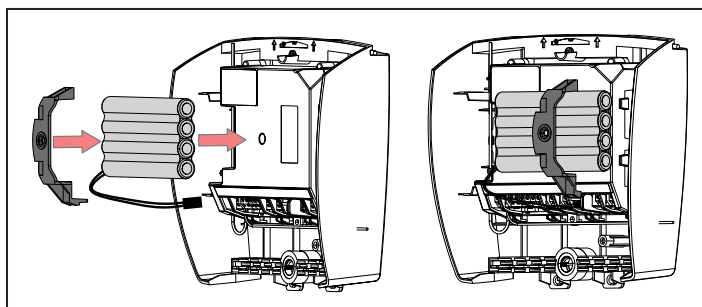

► Technische Daten der Batterie

- Autonomie: 10 Zyklen nacheinander oder 24 Stunden bei einem Tor in einwandfreiem Zustand.
- Optimale Ladezeit vor Einsatz der Batterie: 48 Stunden.
- Lebensdauer: 3 Jahre.

Sie können die Lebensdauer Ihrer Batterie verlängern, indem Sie Ihr Tor 3 Mal pro Jahr vom Strom trennen und es mit Hilfe der Batterie einige Male öffnen und schließen.

3.4 Externe Zusatzantenne (Option)



Eine externe Zusatzantenne mit größerer Reichweite kann die Drahtantenne ersetzen.

Sie wird oben auf dem Pfeiler angebracht und muss allseitig frei stehen.

Sie wird an die Klemmen 1 und 2 (blaues Schild „ANT“) des Schaltkastens angeschlossen:

- Die Seele des Kabels an Klemme 1,
- die geflochtene Hülle (Masse) an Klemme 2.

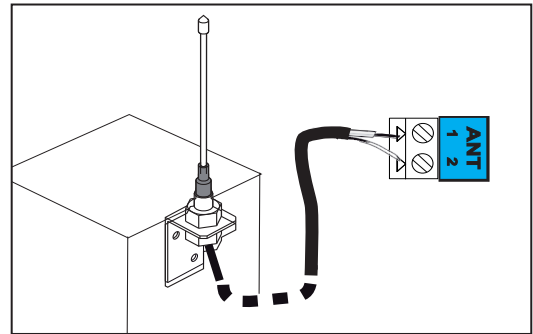

3.5 Video-Türsprechanlage (Option)



Dieses Zubehör ist mit einer Solarstromversorgung nicht kompatibel. Nur spannungslose, potenzialfreie Kontakte anschließen.

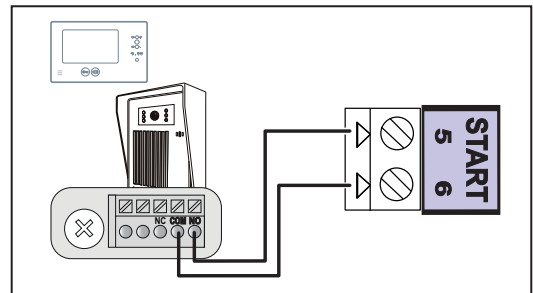

3.6 Schlüsselschalter (Option)



Dieses Zubehör ist mit einer Solarstromversorgung nicht kompatibel.

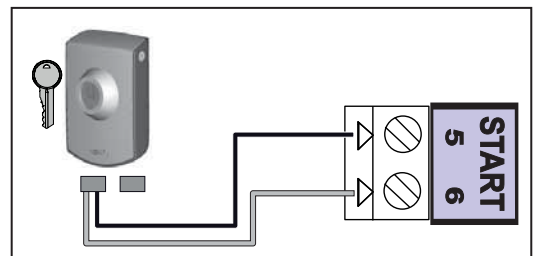

3.7 Umfeldbeleuchtung (Option)



Dieses Zubehör ist mit einer Solarstromversorgung nicht kompatibel. Verwenden Sie ausschließlich Halogen- oder Leuchtstofflampen mit maximal 500 W für die Umfeldbeleuchtung.

► Funktion der Umfeldbeleuchtung

Die Umfeldbeleuchtung schaltet bei jeder Inbetriebnahme des Antriebs ein. Sie erlischt automatisch 1 Minute und 30 Sekunden nach Ende der Bewegung.

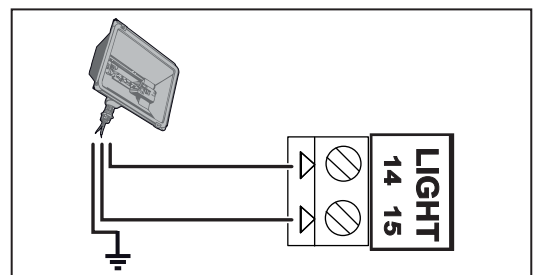

3.8 Solarstromversorgung (Option)



Schließen Sie den Antrieb nie an eine 230 V-Versorgung an, solange er an eine Solarstromversorgung angeschlossen ist. Gefahr der Beschädigung des elektronischen Steuergeräts des Antriebs.

Wenn der Antrieb mit Solarstrom funktioniert:

- das Tor kann nur mit Funksendern und fest Funkbedieneinheiten gesteuert werden (per Kabel angeschlossenen Steuerungen sind deaktiviert),
- Die per Kabel verbundenen Sicherheitseinrichtungen (Lichtschanke, Signalleuchte) bleiben aktiviert.

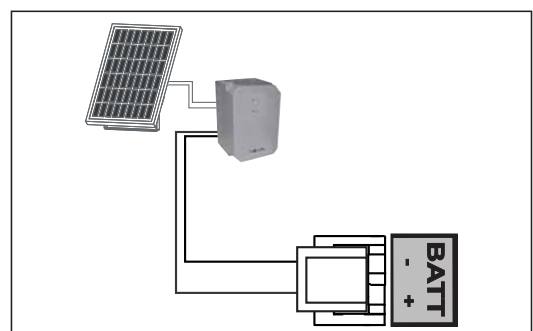

4.1 Fußgängeröffnung

► Funktion der Fußgängeröffnung

<p>Fußgängeröffnung (Antrieb M1) durch Betätigen der aktivierten Taste.</p>	
<p>Anhalten des Tors während des Öffnens durch erneutes Drücken auf die aktivierte Taste.</p>	
<p>Schließen durch erneutes Drücken der aktivierten Taste.</p>	

► Aktivierung der Fußgängeröffnung

i Die Taste 1 der Funksender mit 2 oder 4 Tasten kann nicht auf die Fußgängeröffnung des Tors programmiert werden. Weitere Informationen siehe „Beschreibung der Funksender“, Seite 27.

<p>1</p> <p>Betätigen Sie den Knopf der Steuerelektronik 2 Sekunden lang. Die LED leuchtet auf.</p>	<p>2</p> <p>Legen Sie den Funksender an der Zielmarkierung der Steuerelektronik an.</p>	<p>3</p> <p>Drücken Sie die Taste 2 des Funksenders. Die LEDs „RADIO“ und leuchten auf und verlöschen wieder. Der Personendurchgang ist an dieser Taste aktiviert.</p>
--	--	---

i Entfernen Sie sich von der Steuerelektronik, um die Fußgängeröffnung zu testen.

► Deaktivierung der Fußgängeröffnung

Wiederholen Sie das Verfahren „Aktivierung der Fußgängeröffnung“ mit der Taste, für die die Fußgängeröffnung deaktiviert werden soll. Die LED leuchtet auf und verlöscht wieder. Die Fußgängeröffnung ist an dieser Taste deaktiviert.

4.2 Automatischer Zulauf

► Funktion des automatischen Zulaufs

Drücken Sie die Taste 1 des Funksenders, um das Tor zu öffnen.









Das Tor schließt nach 30 Sekunden erneut bzw. nach 5 Sekunden, wenn die Lichtschranke eine Durchquerung erfasst.

Der automatische Zulauf des Tors kann unterbrochen werden, indem die Taste 1 des Funksenders betätigt wird. Drücken Sie die Taste 1 des Funksenders erneut, um das Tor danach wieder zu schließen.

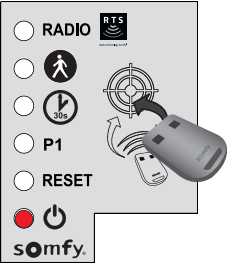
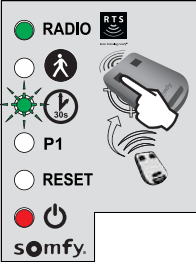

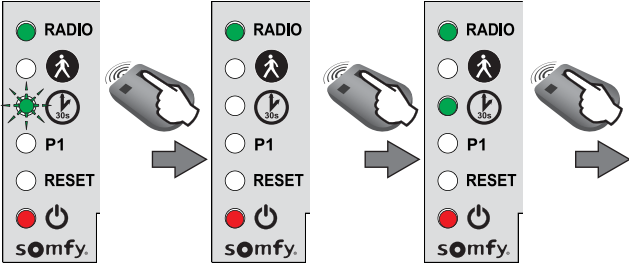

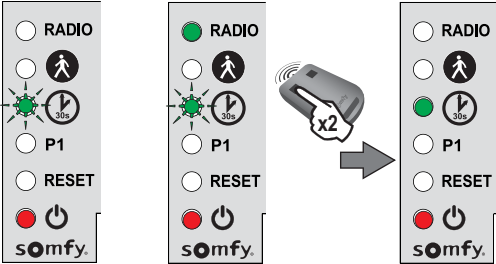



► Aktivierung des automatischen Zulaufs

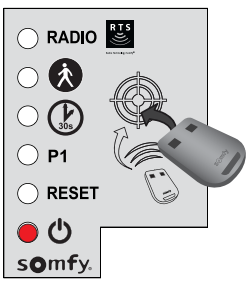
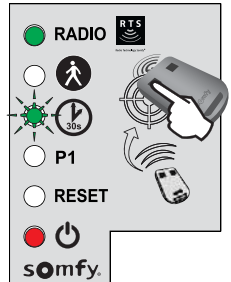

Der automatische Zulauf kann nur dann aktiviert werden, wenn eine Lichtschranke verkabelt und von der Steuerelektronik des Antriebs erfasst ist.

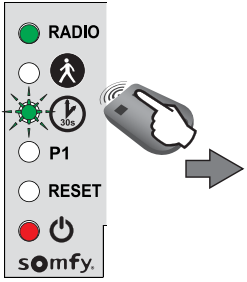
<p>1</p>  <p>Betätigen Sie den Knopf  der Steuerelektronik 2 Sekunden lang. Die LED  leuchtet auf.</p>	<p>2</p>  <p>Legen Sie den Funksender an der Zielmarkierung der Steuerelektronik an.</p>	<p>3</p>  <p>Halten Sie die Taste 1 des Funksenders gedrückt, bis die LED  blinkt.</p> <div style="border: 1px solid orange; padding: 5px; margin-top: 10px;"> <p>i Nachdem Schritt 3 abgeschlossen ist, können Sie die nachfolgenden Schritte aus der Entfernung durchführen (ohne Ablegen des Funksenders auf die Zielmarkierung).</p> </div>
<p>4</p>  <p>Halten Sie die Taste 2 des Funksenders gedrückt, bis die LED  verlöscht und dann dauerhaft aufleuchtet.</p>	<p>5</p>  <p>Wenn die Taste 2 losgelassen wird, blinkt die LED . Drücken Sie 2 Mal auf die Taste 1 des Funksenders. Die LED  leuchtet weiter. Der automatische Zulauf ist aktiviert.</p>	

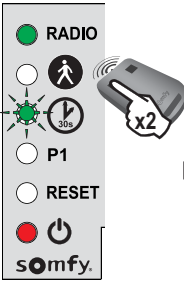
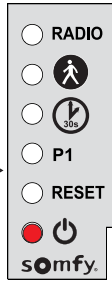
► Deaktivierung des automatischen Zulaufs

<p>1</p>  <p>Betätigen Sie den Knopf  der Steuerelektronik 2 Sekunden lang. Die LED  leuchtet auf.</p>	<p>2</p>  <p>Legen Sie den Funksender an der Zielmarkierung der Steuerelektronik an.</p>	<p>3</p>  <p>Halten Sie die Taste 1 des Funksenders gedrückt, bis die LED  blinkt.</p>
<p>4</p>  <p>Drücken Sie die Taste 2 des Funksenders. Die LED  blinkt.</p>	<p>5</p>  <p>Drücken Sie 2 Mal auf die Taste 1 des Funksenders.</p>	<p>6</p>  <p>Die LED  brennt nicht. Der automatische Zulauf ist deaktiviert.</p>

5.1 Beschreibung der Funksender

Die RTS-Funksender von Somfy können je nach Programmierung folgende Funktionen auslösen:

- Vollöffnung des Tors
- Fußgängeröffnung des Tors
- Ansteuerung anderer RTS-Produkte von Somfy (Beispiele: Antrieb für Garagentor, Rollläden etc.)

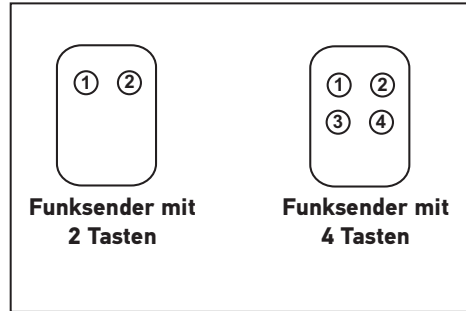

i Die mit dem Kit gelieferten Funksender sind bereits eingelernt und so programmiert, dass die Taste 1 der Funksender die Vollöffnung des Tors bewirkt.

i Sie können bis zu 16 Bedieneinheiten einlernen (Funksender, andere Funkbedieneinheiten). Wenn eine 17. Bedieneinheit eingelernt wird, wird die erste eingelernte Bedieneinheit automatisch gelöscht.

i Wenn die Fußgängeröffnung programmiert werden soll, muss diese unbedingt auf der Taste nach der Vollöffnung eingelernt werden (Beispiel: Vollöffnung (Beispiel: Vollöffnung wird von Taste 2 ausgelöst, Fußgängeröffnung von Taste 3). Die Fußgängeröffnung kann nicht auf der Taste 1 des Funksenders programmiert werden.

► Programmiermöglichkeiten der Funksender mit 2 Tasten

	Taste ①	Taste ②
Möglichkeit 1	Vollöffnung	Fußgängeröffnung oder andere RTS-Automatikvorrichtung von Somfy
Möglichkeit 2	Anderes RTS-Produkt von Somfy	Vollöffnung

► Programmiermöglichkeiten der Funksender mit 4 Tasten

	Taste ①	Taste ②	Taste ③	Taste ④
Möglichkeit 1	Vollöffnung	Fußgängeröffnung oder andere RTS-Automatikvorrichtung von Somfy	Anderer RTS-Automatikvorrichtung von Somfy	Anderer RTS-Automatikvorrichtung von Somfy
Möglichkeit 2	Anderer RTS-Automatikvorrichtung von Somfy	Vollöffnung	Fußgängeröffnung oder andere RTS-Automatikvorrichtung von Somfy	Anderer RTS-Automatikvorrichtung von Somfy
Möglichkeit 3	Anderer RTS-Automatikvorrichtung von Somfy	Anderer RTS-Automatikvorrichtung von Somfy	Vollöffnung	Fußgängeröffnung oder andere RTS-Automatikvorrichtung von Somfy
Möglichkeit 4	Anderer RTS-Automatikvorrichtung von Somfy	Anderer RTS-Automatikvorrichtung von Somfy	Anderer RTS-Automatikvorrichtung von Somfy	Vollöffnung

► Verwendung eines Funksenders mit 3 Tasten

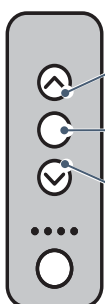

Öffnen

Drücken Sie die Taste „Öffnen“ des Funksenders, um das Tor ganz zu öffnen.

Stopp

Drücken Sie die mittlere Taste des Funksenders, um das Tor in Bewegung zu stoppen.

Schließen

Drücken Sie die Taste „Schließen“ des Funksenders, um das Tor zu schließen.

i Der Funksender mit 3 Tasten kann nicht zu einer Veränderung der Programmierung des Antriebs verwendet werden.

5.2 Einlernen eines Funksenders

► Funksender mit 2 und 4 Tasten

<p>1</p>  <p>Betätigen Sie den Knopf  der Steuerelektronik 2 Sekunden lang. Die LED  leuchtet auf.</p>	<p>2</p>  <p>Legen Sie den neuen, einzulernenden Funksender an der Zielmarkierung der Steuerelektronik an.</p>	<p>3</p>  <p>Drücken Sie kurz die zu programmierende Taste des Funksenders. Die LED „RADIO“ leuchtet auf und verlöscht wieder, sobald die Taste des Funksenders losgelassen wird. Die Vollöffnung ist auf diese Taste programmiert.</p>
--	--	--

► Funksender mit 3 Tasten

<p>1</p>  <p>Betätigen Sie den Knopf  der Steuerelektronik 2 Sekunden lang. Die LED  leuchtet auf.</p>	<p>2</p>  <p>Legen Sie den neuen, einzulernenden Funksender an der Zielmarkierung der Steuerelektronik an.</p>	<p>3</p>  <p>Drücken Sie kurz eine Taste des einzulernenden Funksenders. Die LED „RADIO“ leuchtet auf und verlöscht wieder, sobald die Taste des Funksenders losgelassen wird. Der Funksender ist eingelernt.</p>
---	---	---

5.3 Löschen der Funksender

Siehe „Einstellungen löschen“, Seite 30.







Der Antrieb muss während der Reinigung, Wartung und beim Austausch von Bauteilen von der Stromversorgung getrennt sein.

6.1 Support

Bei Fortbestehen des Defekts, anderen Problemen oder Fragen zu unseren Antrieben steht Ihnen unser Benutzerforum zur Verfügung: www.somfy.com.

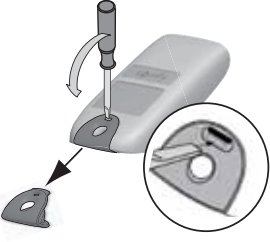
6.2 Austausch der Batterie des Funksenders

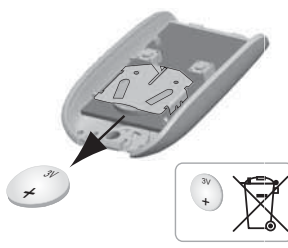





In der Regel halten Batterien 2 Jahre.

<p>1</p>  <p>Entfernen Sie den Clip des Funksenders.</p>	<p>2</p>  <p>Führen Sie den Schraubenzieher in den Schlitz ein und hebeln Sie die Abdeckung ab.</p>	<p>3</p>  <p>Nehmen Sie die Batterie mit Hilfe eines Schraubenziehers heraus.</p>	<p>4</p>  <p>Ersetzen Sie die Batterie (3 V CR 2430 oder CR 2032).</p>
---	--	---	---

6.3 Einstellungen löschen

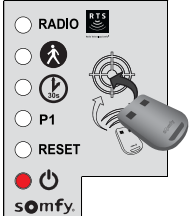
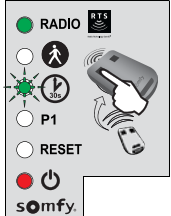
In welchen Fällen müssen die Einstellungen gelöscht werden?

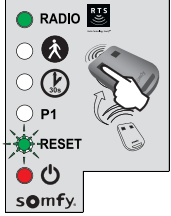
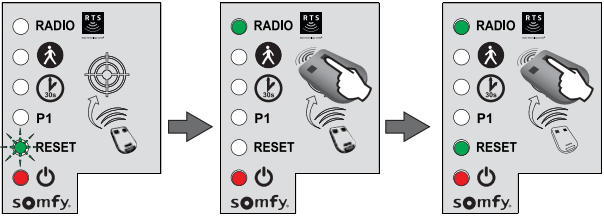
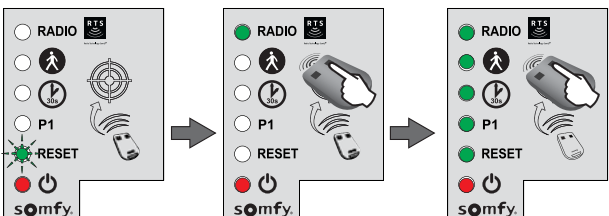
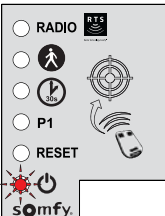
- Wenn Sie nach dem Einlernen der Torwege eine Positionsänderung am Öffnungsanschlag vornehmen oder die Verkabelung an den Antrieben ändern.
- Falls das Tor bei normaler Benutzung gelegentlich wieder von alleine aufläuft.

<p>1</p>  <p>Betätigen Sie den Knopf  der Steuerelektronik 2 Sekunden lang. Die LED  leuchtet auf.</p>	<p>2</p>  <p>Legen Sie den programmierbaren Funksender auf die Zielmarkierung.</p>	<p>3</p>  <p>Halten Sie die Taste 1 des Funksenders gedrückt, bis die LED  blinkt.</p>	<p>4</p>  <p>Drücken Sie 1 Mal auf die Taste 1 des Funksenders. Die LED „RESET“ blinkt.</p>
<p>5 Löschen der Einstellungen*</p>  <p>Halten Sie die Taste 2 des Funksenders gedrückt, bis die LED „RESET“ aufleuchtet.</p>		<p>5 Einstellungen* und die eingelernten Funksender/Bedieneinheiten löschen</p>  <p>Auf Taste 2 des Funksenders drücken, bis alle LEDs aufleuchten.</p>	
<p>6</p> 		<p>Die LED  blinkt zweimal (siehe „Selbsteinlernfunktion für den Torweg“, Seite 20).</p>	



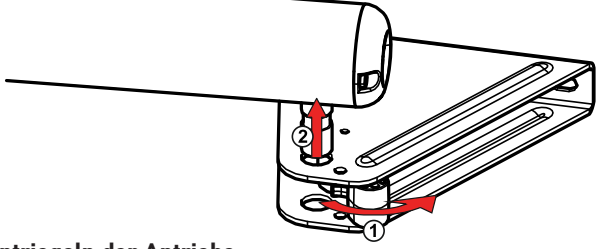
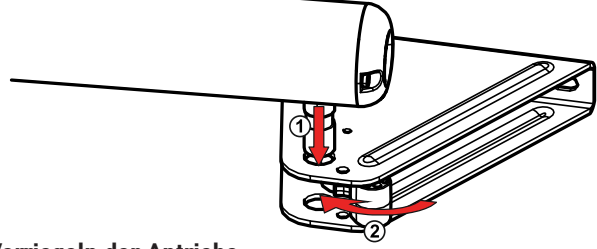

*Torweg, Deaktivierung von Parametern, ...

6.4 Entriegeln/Verriegeln der Antriebe

Wenn die Antriebe entriegelt sind, kann das Tor bei einem Stromausfall manuell bewegt werden.

<p>1</p>  <p>Entriegeln der Antriebe Das Verriegelungsteil ausrasten und die Spindel vom Torflügelbefestigungswinkel abnehmen.</p>	<p>2</p>  <p>Verriegeln der Antriebe Die Spindel anbringen. Das Verriegelungsteil am Mitnehmerdorn einrasten, um ihn zu fixieren.</p>
---	---

6.5 Diagnose

DIAGNOSE		STÖRUNGSBESEITIGUNG
Die Antriebe reagieren nicht auf die Befehle des Funksenders	Die Reichweite des Funksenders ist eingeschränkt.	<ul style="list-style-type: none"> - Die Batterie des Funksenders kontrollieren (siehe „Batteriewechsel am Funksender“, Seite 29). - Die Antenne des Steuerkastens kontrollieren (Verkabelung, Position, siehe Seite 16). - Sicherstellen, dass die Funkwellen nicht durch äußere Einflüsse gestört werden (Strommast, metallbewehrte Mauern usw.). Ist dies der Fall, sollten Sie auch eine externe Antenne anbringen.
	Funksender nicht eingelernt	Den Funksender einlernen (siehe Seite 28).
	Antriebe falsch verkabelt	Die Verkabelung der Antriebe überprüfen (siehe Seite 18).
Die LED  des elektronischen Steuergeräts leuchtet nicht	Antrieb ist im Standbymodus	Den Knopf  der Steuerelektronik 2 Sekunden lang betätigen.
	Stromversorgung zur Steuerelektronik unterbrochen	<ul style="list-style-type: none"> - Prüfen Sie die Stromversorgung. - Prüfen Sie das Stromversorgungskabel.
Die LED  des elektronischen Steuergeräts blinkt:		
1 Blinksignal	Betrieb mit Notstrombatterie	Prüfen Sie die Stromversorgung.
2 Blinksignale	Antrieb wartet auf den automatischen Einlernprozess	Den automatischen Einlernprozess für den Torweg starten (siehe Seite 20).
3 Blinksignale	Lichtschanke funktioniert nicht	<ul style="list-style-type: none"> - Sicherstellen, dass die Lichtschanke nicht durch Hindernisse unterbrochen wird. - Die Ausrichtung der Fozellen prüfen. - Die Verkabelung der Lichtschanke überprüfen (siehe Seite 22). - Wenn die Lichtschanke absichtlich abgeklemmt wird, das Verfahren „Deaktivierung des automatischen Zulaufs“, Seite 26, durchführen.
4 Blinksignale	Dauerbefehl am „START“ des Schaltkastens (Klemmen 5-6)	Die Zubehörteile überprüfen, die am „START“-Ausgang des Steuerkastens angeschlossen sind.
5 Blinksignale	Überhitzungsschutz der Elektronik ausgelöst	Lassen Sie die Elektronik abkühlen, bis die LED  wieder ununterbrochen leuchtet.
6 Blinksignale	Kurzschluss am „BUS“ des Schaltkastens (Klemmen 3-4)	Überprüfen Sie die Zubehörteile, die am „BUS“-Ausgang des Schaltkastens angeschlossen sind.
	Kurzschluss am „24 V“ des Schaltkastens (Klemmen 7-9)	Überprüfen Sie das Zubehör, das am „24 V“-Ausgang des Schaltkastens angeschlossen ist.
	Kurzschluss an der „Signalleuchte“ des Schaltkastens (Klemmen 8-9)	Prüfen Sie die Verdrahtung der Signalleuchte (siehe Seite 22).
	Kurzschluss am Antrieb	Die Verkabelung der Antriebe überprüfen (siehe Seite 18).
7 Blinksignale	Elektronikstörung	Wenden Sie sich an den Somfy-Kundendienst.
Das Tor öffnet sich wieder nach Abschluss des Schließvorgangs		Die Befestigungswinkel der Torflügel lösen und etwas zur Mitte des Tores verschieben.

Spannungsversorgung	230 V-50 Hz / 24 V (Solar)
Antriebsart	24 V
Antriebsleistung	120 W
Maximaler Stromverbrauch (mit Umfeldbeleuchtung)	600 W
Verbrauch im Standby-Betrieb	3 W (ohne Zubehör)
Max. Anzahl der Bewegungen pro Tag	20 Zyklen/Tag 10 Zyklen/Tag (Solar)
Dauer der Öffnung	Min. 20 s bis 90°
Automatische Hinderniserkennung	Entspricht der Norm EN 12 453
Betriebstemperatur	-20 °C bis +60 °C
Überhitzungsschutz	Ja
Schutzart	IP 44
Integrierter Funkempfänger	Ja
Funksender: - Radiofrequenz - Reichweite - Speicherkapazität	433,42 MHz, < 10 mW ~ 30 m 16
Anschlussmöglichkeiten: - Ausgang Signalleuchte - Ausgang für Beleuchtung - Ausgang zur Versorgung sonstiger Zubehöre - Eingang für Notstrombatterie - Eingang für Fotozellen - Potentialfreier Steuereingang	Blinklicht, 24 V, max. 10 W Max. 500 W bei 230 V (nur Halogenlampen oder Leuchtstoffröhren) 24 VDC / max. 15 W Ja Ja Ja (nicht möglich bei Batterie- oder Solarstromversorgung)

Inhoud

Veiligheidsvoorschriften	2	3 Aansluiten van de accessoires	22
- Belangrijke informatie	2	3.1 Foto-elektrische cellen	22
- Staat van het te motoriseren hek	2	3.2 Knipperlicht	22
- Elektrische installatie	2	3.3 Accu (optie)	22
- Ligging van de kabels	3	3.4 Aparte antenne (optie)	23
- Veiligheidsvoorschriften met betrekking tot de installatie van de motorisatie	3	3.5 Videofoon (optie)	23
- Veiligheidsvoorschriften met betrekking tot het gebruik	3	3.6 Contactslot (optie)	23
- Veiligheidsvoorschriften met betrekking tot het onderhoud	4	3.7 Zoneverlichting (optie)	23
- Over de batterijen	4	3.8 Zonne-energievoeding (optie)	23
- Recycling en afvalverwerking	4	4 Geavanceerde instellingen	24
- Reglementering	4	4.1 Voetgangersopening	24
- Risicopreventie	4	- Werking van de voetgangersopening	24
Productbeschrijving	6	- De voetgangersopening activeren	24
- Inhoud van het pakket	6	- De voetgangersopening deactiveren	24
- Beschrijving van het product	7	4.2 Automatische sluiting	25
- Afmeting	7	- Werking van het automatisch sluiten	25
- Toepassingsgebied	7	- Het automatisch sluiten activeren	25
- Algemeen overzicht van de installatie	8	- Het automatisch sluiten de-activeren	26
- Beschrijving van de bedieningselektronica	9	5 Programmeren van de afstandsbedieningen	27
Voorwaarden voor de installatie	9	5.1 Presentatie van de afstandsbedieningen	27
- Voor de installatie te controleren punten	9	- Programmeringsmogelijkheden met de afstandsbediening met 2 toetsen	27
- Benodigde elektrische uitrusting	10	- Programmeringsmogelijkheden met de afstandsbediening met 4 toetsen	27
- Benodigde kabels	10	- Gebruik van een afstandsbediening met 3 toetsen	27
- Benodigd gereedschap voor het installeren (niet meegeleverd)	11	5.2 Een afstandsbediening toevoegen	28
- Benodigd materiaal voor het installeren (niet meegeleverd)	11	- Afstandsbediening met 2 of 4 toetsen	28
1 Installatie	12	- Afstandsbediening met 3 toetsen	28
1.1 De maten opmeten	12	5.3 De afstandsbedieningen wissen	28
1.2 Bevestiging van de beugels van de paal	13	6 Hulp bij storingen	29
- De assen AM en AH aftekenen	13	6.1 Assistentie	29
- In de palen boren	13	6.2 De batterij van de afstandsbediening vervangen	29
- De bevestigingsbeugel aan de paal bevestigen	14	6.3 De instellingen wissen	30
- De werkcilinder op de bevestigingsbeugel monteren	14	6.4 De motoren ontgrendelen/vergrendelen	30
1.3 Bevestiging van de motoren aan de vleugels	14	6.5 Diagnose	31
1.4 Installatie van de bedieningseenheid	16	7 Technische gegevens	32
- Positie van de bedieningseenheid	16		
- De afdichtstrook installeren	16		
- De positie van de antenne controleren	16		
- De bedieningseenheid bevestigen	16		
1.5 Aansluiten van de motoren	18		
1.6 Aansluiten op de netvoeding	18		
2 Ingebruikname en standaard gebruik	19		
2.1 De spanning inschakelen op de installatie	19		
2.2 Instelling van de openingsstopper	19		
2.3 Zelfprogrammering van de slag van het hek	20		
2.4 De bedieningseenheid sluiten	21		
2.5 Stand-by/Wekken van de bedieningselektronica	21		
2.6 Geheel openen en sluiten van het hek	21		
2.7 Detectie van obstakel	21		
2.8 Informatie van de gebruikers	21		

➤ Veiligheidsvoorschriften

 Dit symbool signaleert een gevaar waarvan de ernst hieronder beschreven worden.

GEVAAR

Signaleert een gevaar met de dood of een ernstig letsel tot gevolg.

WAARSCHUWING

Signaleert een gevaar dat de dood of ernstig letsel kan veroorzaken.

VOORZICHTIG

Signaleert een gevaar dat licht of middelmatig letsel kan veroorzaken.

LET OP

Signaleert een gevaar dat het product kan beschadigen of vernietigen.

WAARSCHUWING

WAARSCHUWING - Belangrijke veiligheidsinstructies
Voor de veiligheid van personen is het belangrijk dat alle instructies strikt worden opgevolgd, want een onjuiste installatie kan ernstig letsel veroorzaken. Bewaar deze instructies. De installateur moet alle gebruikers informeren over het veilig en volgens de gebruiksaanwijzing gebruiken van de motorisatie. De gebruiksaanwijzingen moet aan de eindgebruiker overhandigd worden.

➤ Belangrijke informatie

Dit product is een motorisatie voor een klaphek, voor gebruik in de woonomgeving zoals vastgelegd in de norm EN 60335-2-103 en is conform deze norm. Deze instructies zijn geschreven binnen het kader van deze normen en om de veiligheid van personen en goederen te garanderen.

WAARSCHUWING

Ieder gebruik van dit product buiten het toepassingsgebied dat in deze handleiding is beschreven, is verboden (zie paragraaf "Toepassingsgebied" van de handleiding). Het gebruik van een niet door Somfy voorgeschreven accessoire of onderdeel is verboden - de veiligheid van personen is niet langer verzekerd. Somfy is niet aansprakelijk voor schade die het gevolg is van het niet naleven van de aanwijzingen in deze handleiding.

Raadpleeg, bij twijfel tijdens de installatie van de motorisatie of voor aanvullende informatie, de website www.somfy.com. Deze instructies kunnen veranderen naar aanleiding van aanpassingen van de normen of van de motorisatie.

➤ Staat van het te motoriseren hek

Controleer, voor het installeren van de motorisatie, of:

- het hek mechanisch in goede staat verkeert.
- het hek in elke positie stabiel is.
- de motorisatie stevig kan worden bevestigd op de draagconstructie van het hek. Versterk ze indien nodig.
- het hek gaat gemakkelijk dicht en open met de hand met een kracht van minder dan 150 N.
- het temperatuurbereik dat vermeld is op de motor geschikt is voor de plaats waar het systeem geïnstalleerd wordt.

LET OP

Houd de motorisatie droog.
Installeer de motorisatie niet in een explosieve omgeving.

WAARSCHUWING

Controleer of er door de beweging van het aangedreven deel geen gevaarlijke zones (waar lichaamsdelen geplet, afgesneden of bekneld kunnen worden) zijn tussen het aangedreven deel en de vaste omringende delen of dat deze duidelijk zijn aangegeven op de installatie (zie "Risicopreventie").

Bevestig de stickers die waarschuwen tegen beknelling op een duidelijk zichtbare plaats of dichtbij de eventuele vaste bedieningsorganen.

➤ Elektrische installatie

GEVAAR

De installatie van de elektrische voeding moet plaatsvinden in overeenstemming met de geldende normen in het land van installatie van de motorisatie en worden uitgevoerd door een gekwalificeerde technicus.

GEVAAR

De elektrische leiding mag uitsluitend gebruikt worden voor de motorisatie en moet voorzien zijn van een beveiliging door:

- een smeltveiligheid of een automatische zekering van 10 A,
- en door een aardlekschakelaar (30 mA).

Er moet een omnipolaire uitschakeling van de voeding aanwezig zijn. De omnipolaire schakelaars voor het onderbreken van de vaste apparaten moeten rechtstreeks op de voedingsklemmen worden aangesloten en moeten op alle polen een scheidingsafstand tussen de contacten hebben om een complete ont koppeling te garanderen volgens de voorwaarden van overspanningscategorie III. De laagspanningskabels in de open lucht moeten ten minste van het type H07RN-F zijn. De installatie van een overspanningsbeveiliging wordt geadviseerd (verplichte maximum restspanning 2 kV).

► Ligging van de kabels

GEVAAR

De ingegraven kabels moeten in een beschermhuls liggen met voldoende diameter om de kabel van de motor en de kabels van de toebehoren erdoor te leiden.

Gebruik voor niet-ingegraven kabels een kabelgoot die bestand is tegen erover rijdende voertuigen (ref. 2400484).

► Veiligheidsvoorschriften met betrekking tot de installatie van de motorisatie

WAARSCHUWING

Draag geen sieraden (armband, ketting of andere) tijdens de installatie.

Draag bij het werken, boren en lassen speciale brillen en geschikte beschermingen (handschoenen, gehoorbeschermers, enz.).

GEVAAR

Sluit de motorisatie niet aan op de voeding (lichtnet, batterij, zonnecel) voordat de installatie helemaal klaar is.

WAARSCHUWING

Het is streng verboden enig onderdeel van deze set te wijzigen of een onderdeel toe te voegen dat niet in deze handleiding wordt voorgeschreven.

Verlies het bewegende hek niet uit het oog en houd iedereen op afstand tot de installatie klaar is.

Gebruik geen kleefmiddelen om de motorisatie te bevestigen.

WAARSCHUWING

Door de handmatige ontgrendeling kan het hek een onverwachte beweging maken.

Bevestig de sticker van het handbediende ontkoppeling in de buurt van het bedieningsorgaan.

WAARSCHUWING

Installeer vaste bedieningsorganen op een hoogte van ten minste 1,5 m en in het zicht van het hek maar buiten het bereik van de bewegende delen.

Controleer na de installatie dat:

- het mechanisme correct is ingesteld.
- de handmatige ontgrendeling correct werkt.
- de motorisatie verandert van richting als het hek een voorwerp van 50 mm tegenkomt dat geplaatst is op de halve hoogte van de vleugel.

WAARSCHUWING

Bij een automatisch werkend systeem of wanneer het bedieningspunt buiten het zicht is aangebracht, is het installeren van foto-elektrische cellen verplicht.

De motorisatie in automatische modus werkt minimaal in één richting zonder tussenkomst van de gebruiker.

Bij een werking in automatische modus of wanneer het hek uitkomt op de openbare weg, kan het installeren van een knipperlicht vereist zijn in overeenstemming met de regelgeving van het land waarin de motorisatie in gebruik is.

► Veiligheidsvoorschriften met betrekking tot het gebruik

WAARSCHUWING

Deze motorisatie mag worden gebruikt door kinderen van ten minste 8 jaar en door personen met beperkte fysieke, zintuiglijke of geestelijke vermogens of zonder ervaring en kennis van het apparaat, indien zij onder toezicht staan of instructies hebben gekregen over het veilig gebruik van de motorisatie en de mogelijke gevaren ervan hebben begrepen. Laat kinderen niet met het bedieningssysteem van het hek spelen. Houd de afstandsbedieningen buiten het bereik van kinderen. Laat het apparaat niet schoonmaken door kinderen.

Het geluidsdrukkniveau van de motorisatie is lager dan of gelijk aan 70 dB(A). Hierbij is geen rekening gehouden met geluid dat wordt veroorzaakt door de constructie waarmee de motorisatie is verbonden.

WAARSCHUWING

De installateur moet elke mogelijk gebruiker informeren over het gebruik van de motorisatie volgens de aanwijzingen in deze handleiding. Het is belangrijk erop te letten dat alleen personen die hierover zijn geïnformeerd het hek in beweging kunnen zetten.

De gebruiker mag het bewegende hek niet uit het oog verliezen en iedereen op afstand houden tot het hek compleet geopend of gesloten is.

Houd het hek niet tegen als het in beweging is.

WAARSCHUWING

Als het systeem niet goed werkt, onderbreek dan de voeding en ontgrendel direct de motorisatie om de toegang mogelijk te maken. Neem contact op met de helpdesk van Somfy.

Probeer het hek niet handmatig te openen als de motorisatie niet ontgrendeld is. Let op dat de beweging van het hek niet wordt belemmerd door een natuurlijk obstakel (tak, steen, hoog gras, enz.).

► Veiligheidsvoorschriften met betrekking tot het onderhoud

! GEVAAR

De motorisatie moet zijn losgemaakt van alle voedingsbronnen gedurende het schoonmaken, het onderhoud en tijdens het vervangen van onderdelen.

! WAARSCHUWING

Controleer elke maand:

- de installatie op tekenen van slijtage of beschadiging van de kabels en van de montage.
- of de motorisatie verandert van richting als het hek een voorwerp van 50 mm tegenkomt dat geplaatst is op de halve hoogte van het hek.

Gebruik de motorisatie niet als een reparatie of een afstelling noodzakelijk is. Hekken die in slechte staat verkeren moeten worden hersteld, versterkt, of vervangen.

Gebruik uitsluitend originele onderdelen voor elk onderhoud of reparatie.

Voor iedere technische, elektronische of mechanische verandering van de motorisatie is toestemming van de helpdesk van Somfy vereist.

Als de installatie is voorzien van foto-elektrische cellen en/of een knipperlicht, moeten de lenzen van de elektrische cellen en het knipperlicht regelmatig worden schoongemaakt.

► Over de batterijen

! GEVAAR

Houd batterijen/knoopcellen/accu's buiten het bereik van kinderen. Bewaar ze op een plek waar zij er niet bij kunnen. Het is gevaarlijk als zij worden ingeslikt door een kind of een huisdier. Levensgevaar! Als dit ondanks alles toch gebeurt, raadpleeg dan direct een dokter of ga direct naar een ziekenhuis.

Let op dat de batterijen niet worden kortgesloten. Gooi ze niet in het vuur en laad ze niet op. Er kan een explosie plaatsvinden.

► Recycling en afvalverwerking

Voordat de motorisatie wordt afgedankt, moet de accu (indien aanwezig) er uitgehaald worden.

 Gooideadbatterijenvandeafstandsbediening of de accu (indien aanwezig) niet weg met het huisvuil. Lever ze in bij een speciaal afvalpunt, zodat ze gerecycled worden.

 Gooi de oude motorisatie niet weg met het huisvuil. Laat de motorisatie ophalen door de leverancier ervan of lever hem in bij het afvalstation van de gemeente.

► Reglementering

CE Somfy verklaart dat het product dat behandeld wordt en bestemd is om te worden gebruikt volgens de aanwijzingen in dit document, in overeenstemming is met de essentiële eisen en de andere relevante bepalingen van de Europese richtlijnen voor toepassing binnen de Europese Unie en in het bijzonder met de Machinerichtlijn 2006/42/EG en de Richtlijn Radioapparatuur 2014/53/EU.

De complete tekst van de EG-conformiteitsverklaring staat ter beschikking op de website: www.somfy.com/ce. Antoine CREZE, Verantwoordelijke reglementering, Cluses

► Risicopreventie

Herkenning van de risicozones

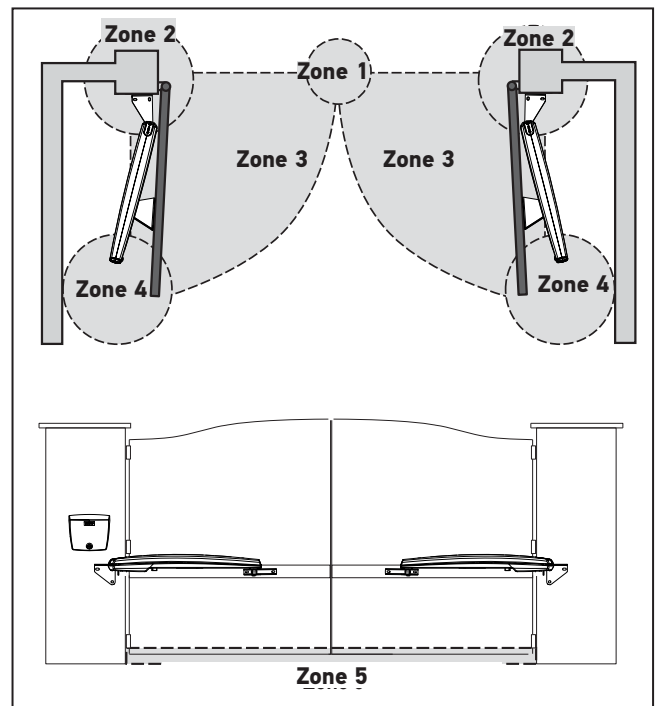

Maatregelen om de risico's tegen te gaan

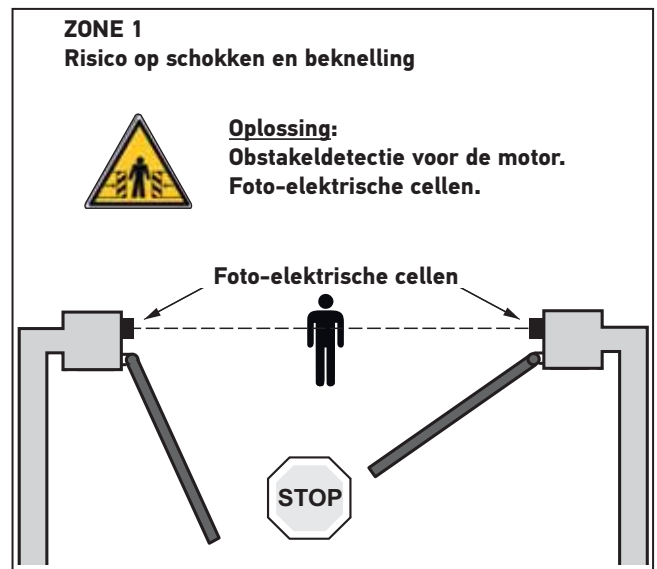

ZONE 2

Risico op beknelling en afsnijden van de handen



Oplossing:

Als de installatie een risico op afsnijding heeft:

- een afstand van ten minste 10 cm aanhouden tussen de vleugel en de paal/muur.
- de hoek van de paal afkappen zonder de paal te verzwakken.

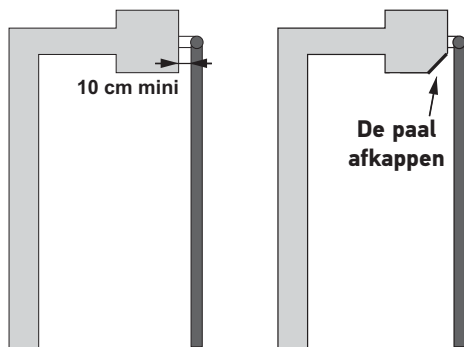

ZONE 4

Risico op opsluiting en beknelling

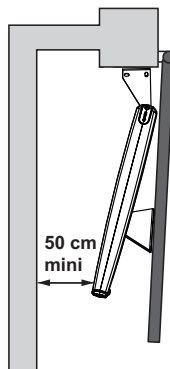

Oplossing:

Obstakeldetectie voor de motor. Als er een zone is waarin men kan worden opgesloten tussen de vleugels en de vaste omringende delen, dan moet u een afstand van ten minste 50 cm aanhouden tussen de vleugels en de vaste delen.

ZONE 3

Risico op schokken

Oplossing:

Obstakeldetectie voor de motor.

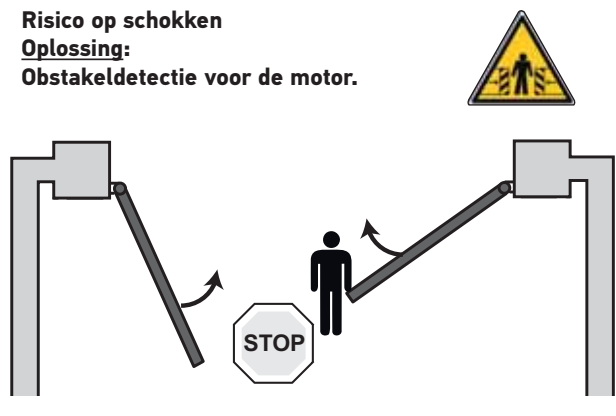

ZONE 5

Risico op meenemen van de voeten



Oplossing:

Als er een gevaarlijk zone voor de voeten is tussen de onderkant van de vleugels en de grond, dan moet u een afstand van ten minste 12 cm of ten hoogste 5 mm aanhouden tussen de onderkant van de vleugels en de grond.

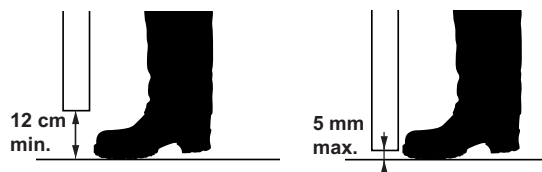

Inhoud van het pakket

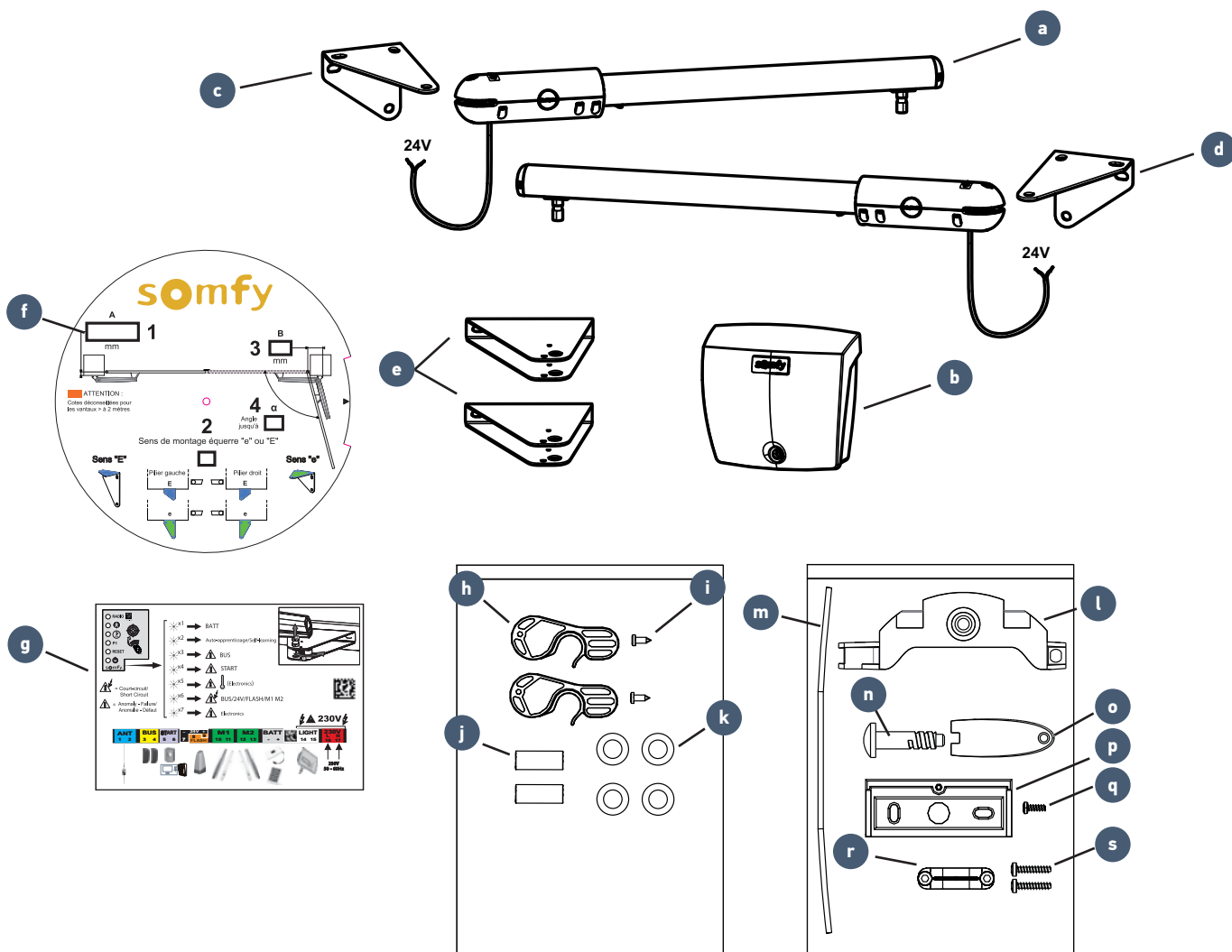

Nr.	Omschrijving	Aantal
a	Werkcilinder 24 V	x2
b	Bedieningseenheid	x1
c	Bevestigingsbeugel links aan paal/muur	x1
d	Bevestigingsbeugel rechts aan paal/muur	x1
e	Bevestigingsbeugel van de vleugel	x2
f	Schijf voor het meten van de maten	x1
g	Geheugenetiket	x1
Zakje accessoires van de werkcilinder		
h	Ontgrendeling	x2
i	Schroef van de ontgrendeling	x2
j	Bevestigingspen werkcilinder aan paal/muurbeugel	x2
k	Platte ring M8x22	x4

Nr.	Omschrijving	Aantal
Zakje met accessoires voor de bedieningseenheid		
l	Accusteun	x1
m	Afdichtstrook	x1
n	Schroef van deksel van de kast	x1
o	Sleutel van het deksel van de kast	x1
p	Bevestigingshoekstuk aan de muur	x1
q	Bevestigingsschroef kast aan hoekstuk	x1
r	Kabelklem	x1
s	Schroef van kabelklem	x2

► Beschrijving van het product

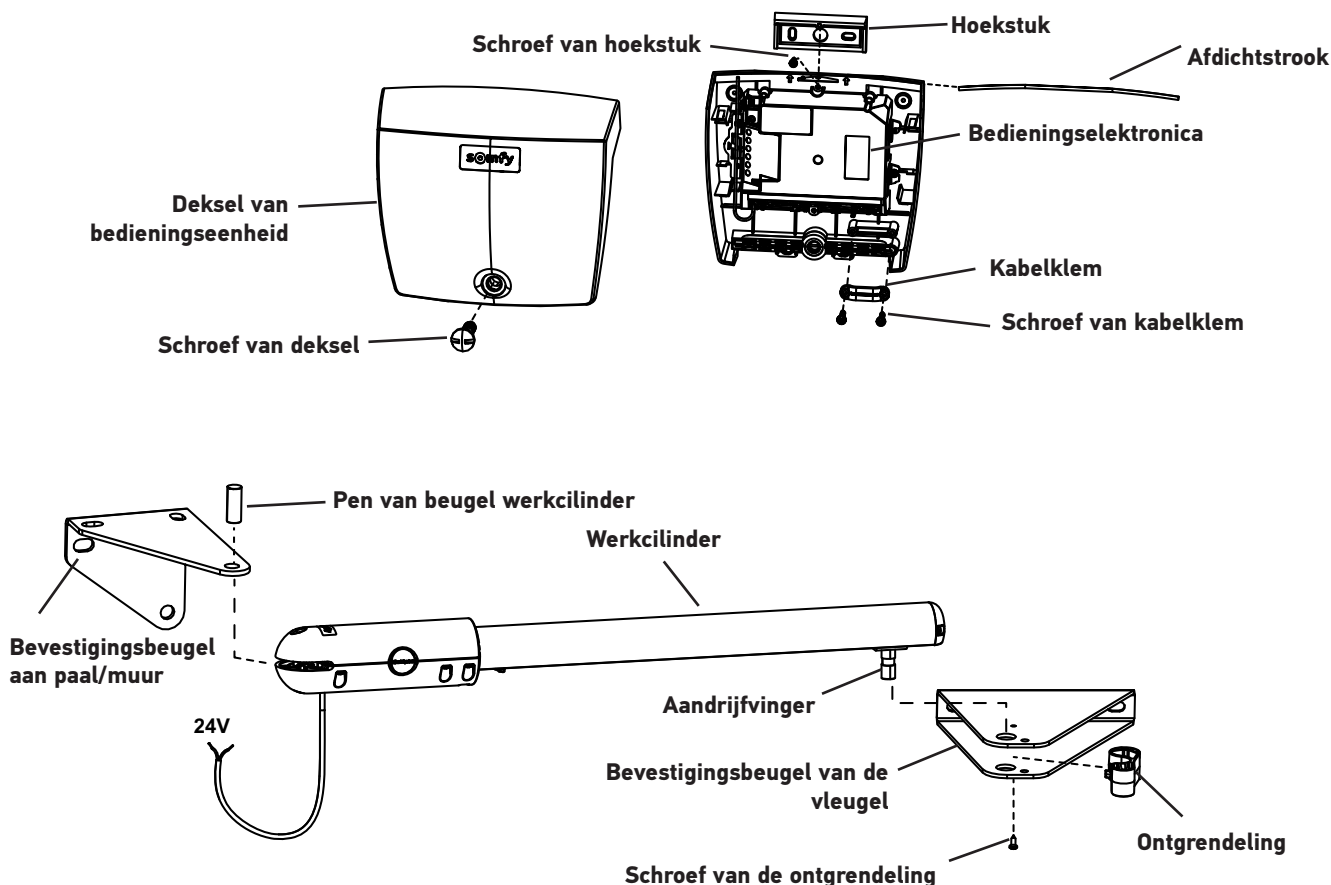

► Afmeting

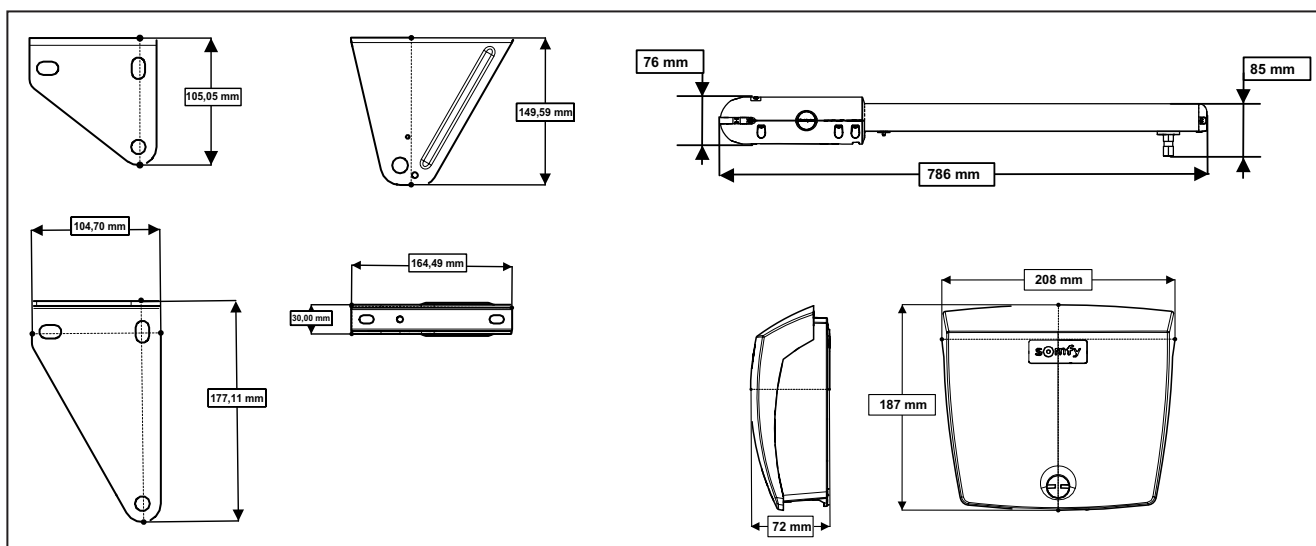

► Toepassingsgebied

Deze automaat is ontworpen voor het motoriseren van openslaande hekken bij een vrijstaand woonhuis.





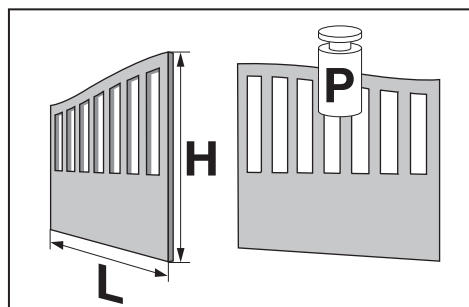

Afmetingen en gewicht van de vleugels

Max. gewicht per vleugel (P)	200 kg
Max. hoogte per vleugel (H)	2 m
Min./Max. breedte per vleugel (L)	1,25 / 2 m

Het type hek (met of zonder openingen) en de klimaatomstandigheden (kans op harde wind), kunnen deze maximumwaarden kleiner maken (zie tabel hieronder).



Afmetingen en gewicht van de te motoriseren vleugels in functie van de windkracht

Windkracht	Effect	Product	SGS LINE
≥ 80 km/u	Tegen de wind in lopen is niet langer mogelijk		Min./Max. breedte Max. gewicht
< 80 km/u > 40 km/u	Boomtakken bewegen		Min./Max. breedte Max. gewicht
			Min./Max. breedte Max. gewicht
≤ 40 km/u	Zand waait op		Min./Max. breedte Max. gewicht
			
			



Hek met openingen



Hek met kleine openingen



Hek zonder openingen

► Algemeen overzicht van de installatie

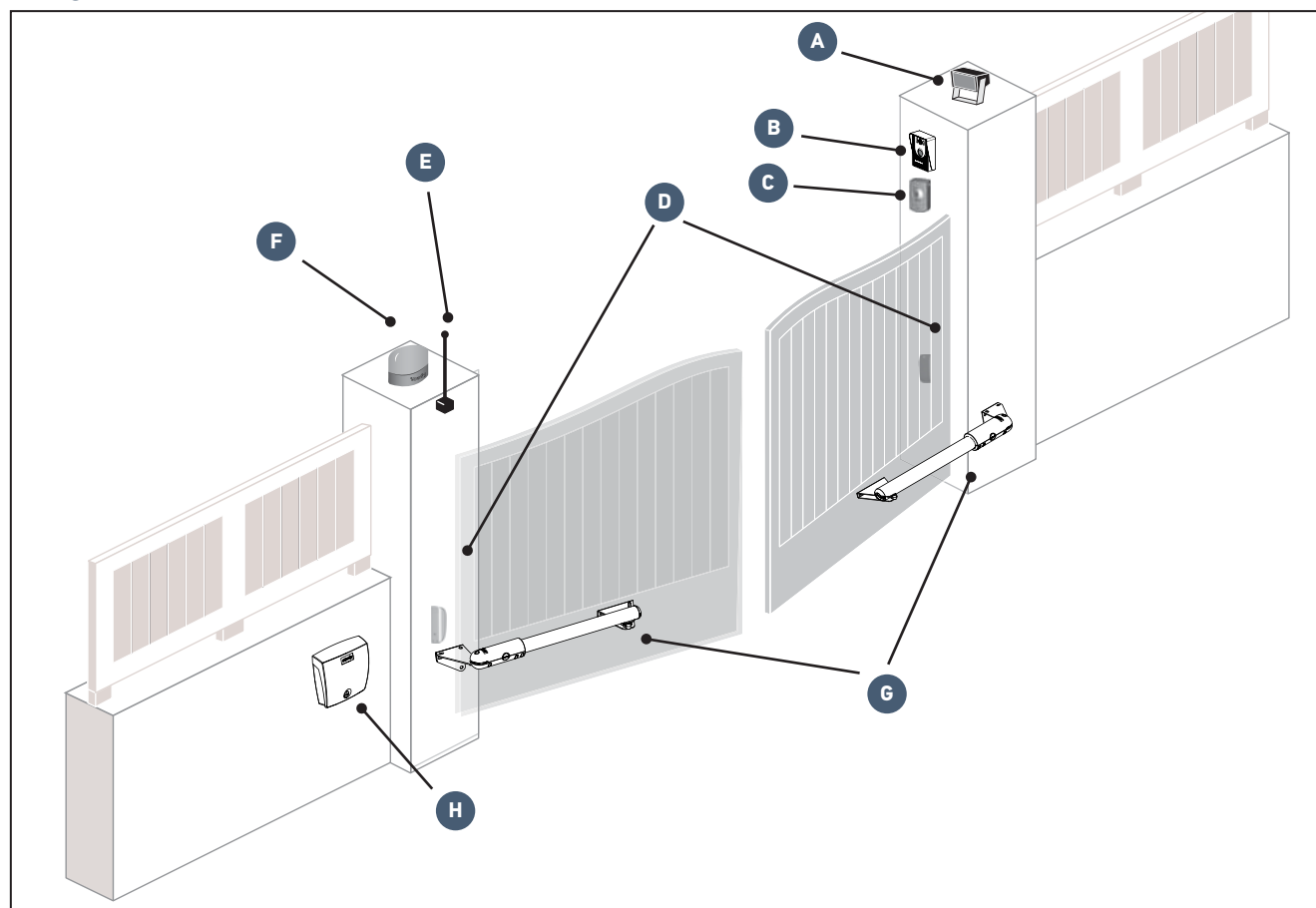

Nummer	Omschrijving
A	Verlichting van de zone*
B	Videofoon*
C	Contactslot*
D	Foto-elektrische cellen

Nummer	Omschrijving
E	Aparte antenne*
F	Knipperlicht
G	Motoren
H	Bedieningseenheid

*optionele accessoires

► Beschrijving van de bedieningselektronica

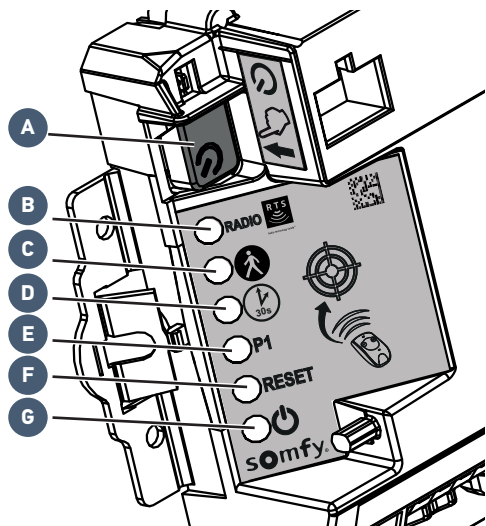

Nr.	Omschrijving	Functie	
A	Knop	Bedieningselektronica uit stand-by halen	
B	RADIO-led	Gaat steeds branden wanneer de bedieningselektronica een radiografisch bedieningssignaal ontvangt	
C	Led	Gaat branden bij het activeren/deactiveren van de voetgangersopening	
D	Led	Brandt	het automatisch sluiten van het hek is geactiveerd
		Uit	het automatisch sluiten van het hek is niet geactiveerd
		Knippert	de instelling "automatisch sluiten" is geselecteerd
E	Led P1	Wordt niet gebruikt	
F	RESET-led	Brandt	alleen de afstellingen of de radiografische instellingen en de bedieningspunten worden gewist
		Knippert	de wisfunctie van de afstellingen en de radiografische bedieningspunten is geselecteerd
G	Led	Brandt	de motorisatie werkt goed - de bedieningselektronica is gewekt
		Uit	de motorisatie werkt goed - de bedieningselektronica is in stand-by
		Knippert	zie "Diagnose" pagina 31

► Voorwaarden voor de installatie

► Voor de installatie te controleren punten

Hek

Het hek verkeert in goede staat: het opent en sluit normaal zonder forceren.
Het blijft over de gehele lengte horizontaal. Het opent naar binnen.

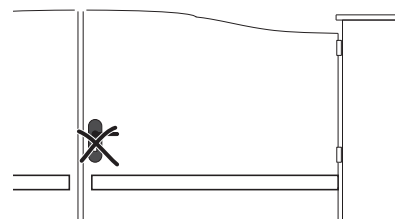
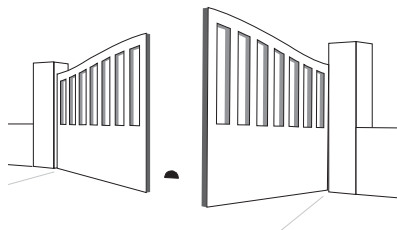
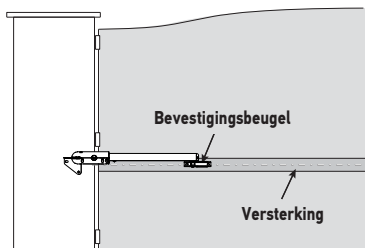

Versterkingen

De motoren moeten worden bevestigd op de horizontale versterkingen van de vleugels, die idealiter op 1/3e van de hoogte van het hek zijn geplaatst. Als er geen versterkingen zijn, zorg dan voor metalen contraplatten van ongeveer 4 mm dik.

Sluitstoppers op de grond

De slag van het hek bij het sluiten moet worden beperkt door stevig op de grond bevestigde stoppers. De openingsstoppers zijn in de motor ingebouwd (zie "Instelling van de openingsstopper" pagina 19).

Mechanisch slot

Als het hek is voorzien van een mechanisch slot, moet dit verwijderd worden.

Palen

De palen moeten stevig zijn en ten minste 21 cm breed zijn. Als dit niet zo is, kunnen voorzieningen op de paal noodzakelijk zijn om een goede plaatsing en bevestiging van het hoekstuk te garanderen. Het wordt afgeraden het hoekstuk op de rand van de paal te monteren: risico van scheuren.

► Benodigde elektrische uitrusting

Benodigde kabels

- Netvoeding: kabel 3 x 1,5 mm² of 3 x 2,5 mm² voor gebruik buiten (minimaal type H07RN-F).
- Verbinding tussen de motoren: kabel 2 x 1 mm²; zorg voor een verdeelkast IP 55 voor het beschermen van de verbinding van de uitgaande kabel van de motor en de verlengkabel naar de bedieningseenheid.
- Verbinding van de fotocellen: kabel 2 x 0,75 mm².



Leg de voedingskabel aan volgens de elektrische normen die gelden in het land van gebruik.

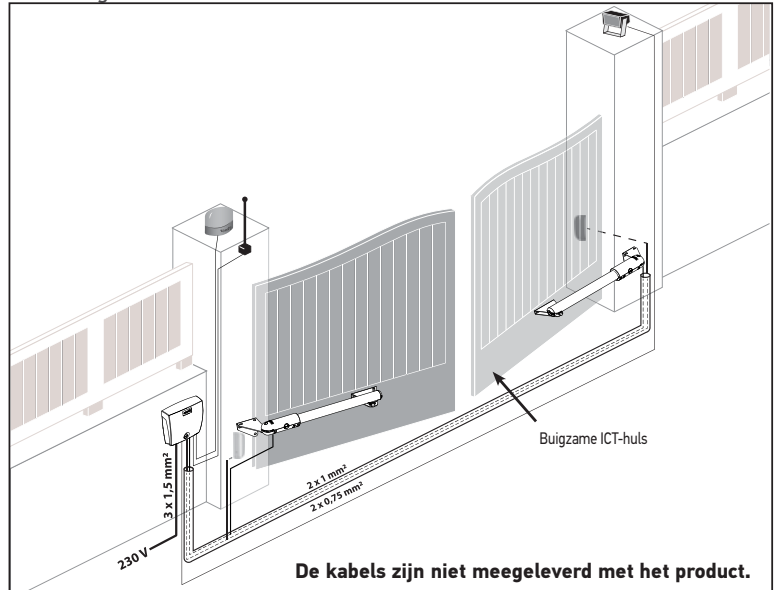
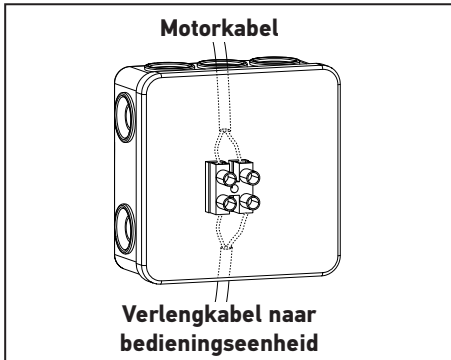

De kabels zijn niet meegeleverd met het product.

Ligging van de kabels

- De ingegraven kabels moeten in een beschermhuls liggen met voldoende diameter om de alle kabels erdoor te leiden.
- Voor een 230 V-aansluitpunt zorgen zo dicht mogelijk bij de plaats van de bedieningseenheid.

► Benodigde kabels



Als het niet mogelijk is de kabel in te graven, gebruik dan een kabeldoorvoer die bestand is tegen overrijdende voertuigen (ref. 2400484).



U vindt gedetailleerde informatie over het aansluiten in het deel "Aansluiten van de accessoires" pagina 22.

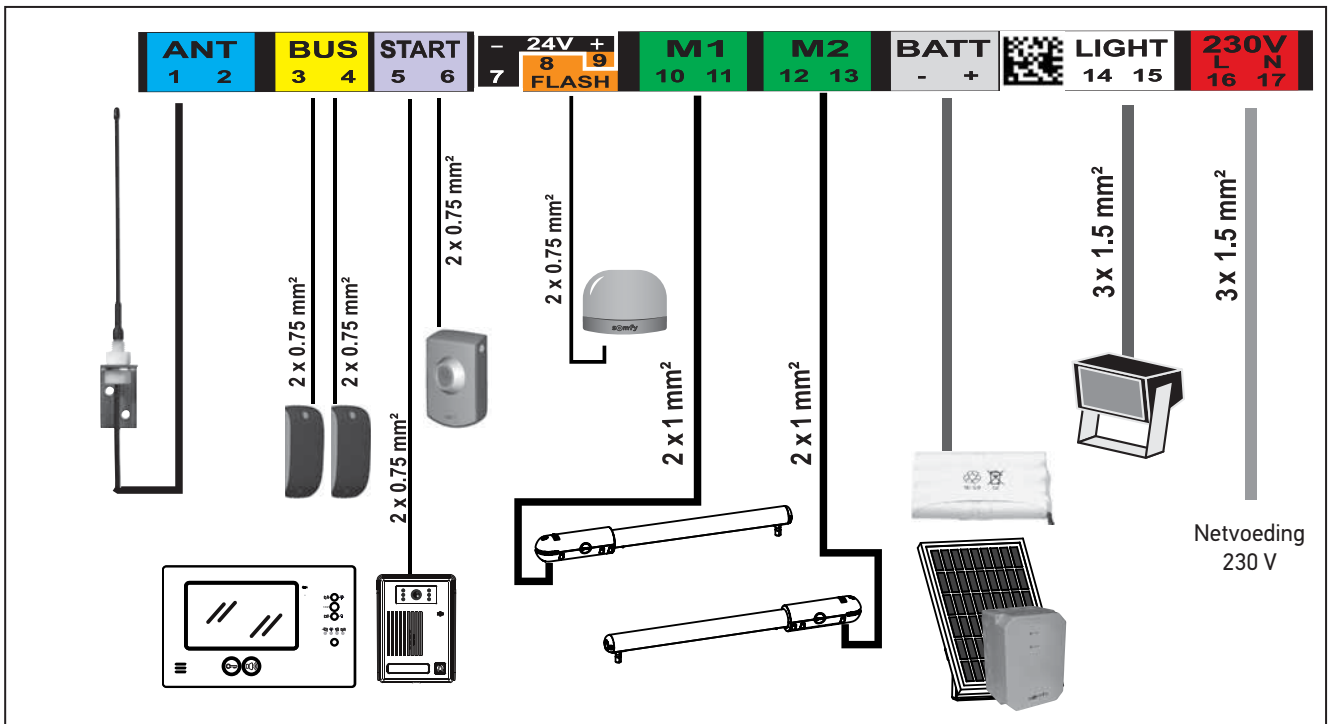

► Benodigd gereedschap voor het installeren (niet meegeleverd)

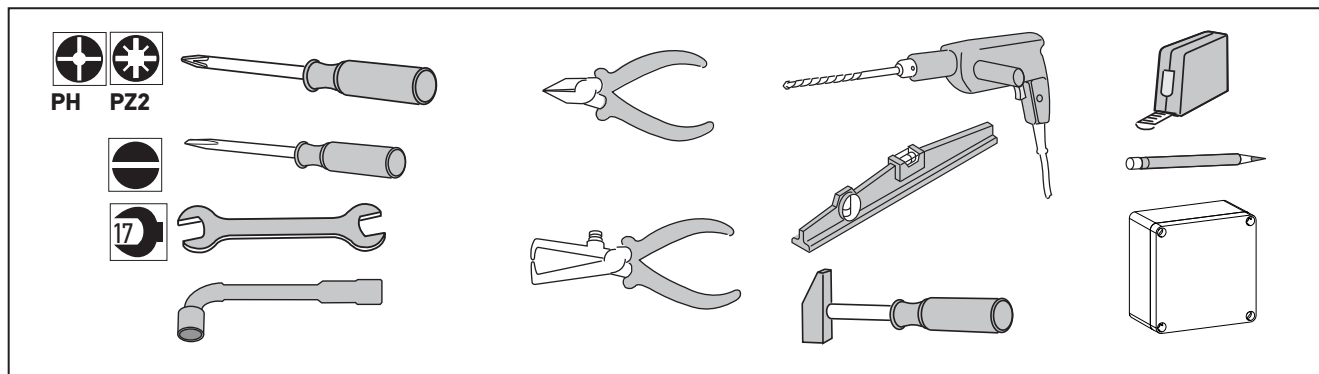

► Benodigd materiaal voor het installeren (niet meegeleverd)

Deze informatie wordt ter indicatie gegeven.

Voor de bevestiging van de ...		Aantal
BEUGELS AAN DE PALEN/MUREN		
	Bevestigingsmiddelen geschikt voor het materiaal van de paal/muur (schroeven, tapeinden, borgmiddelen, enz.): - diameter: 8 tot 10 mm - zeskantkop	6
	Ringen: - binnendiameter: 8 tot 10 mm - buitendiameter: 16 tot 20 mm Moeren: - diameter: 17 mm	6
BEUGELS AAN DE VLEUGELS		
	Bevestigingsmiddelen geschikt voor het materiaal van de versterking van de vleugels: - diameter: 8 mm - lengte geschikt voor de dikte van de versterking van de vleugels	6
	Meegeleverde ringen - binnendiameter: 8 mm - buitendiameter: 22 mm	6
BEDIENINGSEENHEID		
	Bevestigingsmiddelen geschikt voor het materiaal van de paal/muur - schroeven diameter: 3,5 tot 4,5 mm - gefreesde of bolle kop - pluggen type "S" voor beton: S5, S6 of S8	4

1.1 De maten opmeten

Meet de maten op met behulp van de schijf (f) om de positie van de motoren op de palen te bepalen.

N.B.: De aangegeven waarden gelden als de vleugels en hun scharnieren op één lijn liggen.

Opmerking: Er moet een afstand van ten minste 50 cm blijven tussen de vleugels en de vaste delen (zie "Risicopreventie" pagina 4).

1 Meet maat A.

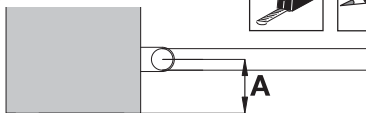

Breng de gemeten maat A over op de schijf.

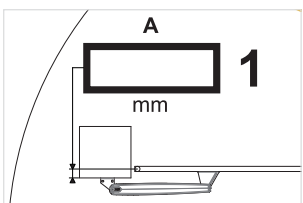

LET OP
Maten niet aan te raden voor de vleugels > 2 meters

3 De maat B bepalen

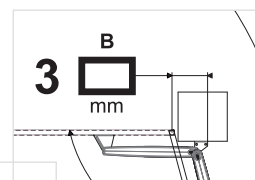

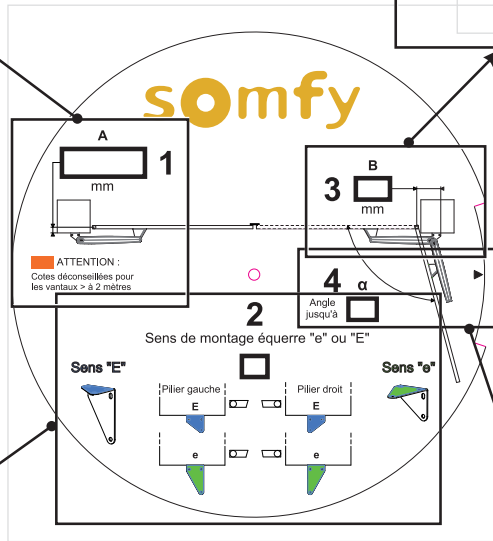

ATTENTION :
Cotes déconseillées pour les vantaux > à 2 mètres

Angle jusqu'à

Sens de montage équerre "e" ou "E"

Sens "E" Pilier gauche E Pilier droit E Sens "e"

2 Noteer de aangegeven montagerichting (e of E) van de bevestigingsbeugel van de werkcilinder aan de paal.

Montagerichting hoekstuk "e" of "E"

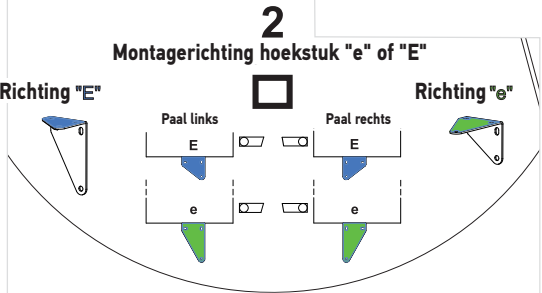

Richting "E" Paal links Paal rechts Richting "e"

! Let op de montagerichting omhoog en omlaag van de beugel.

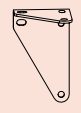

Goede richting

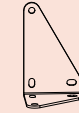

Foute richting

4 De maximale openingshoek α is aangegeven.

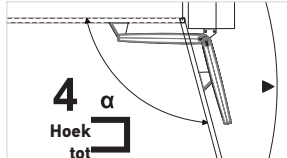

! Houd u aan de op de schijf aangegeven maximale openingshoek.



Advies: maat A is negatief

Als maat A negatief is, dan bevindt het scharnier van de vleugel zich voor de paal. Wij adviseren een vulplaat toe te voegen zodat de bevestigingsbeugel van de werkcilinder op een lijn ligt met het scharnier van de vleugel en dat A gelijk is 0 cm.

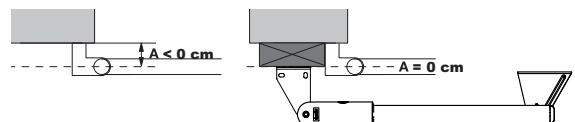

1.2 Bevestiging van de beugels van de paal

► De assen AM en AH aftekenen

1. Breng maat B over op de paal vanaf de hartlijn van het scharnier en teken op de paal een verticale as AM af.
2. Teken de horizontale as AH af op de paal op de helft van de hoogte van de versterking.

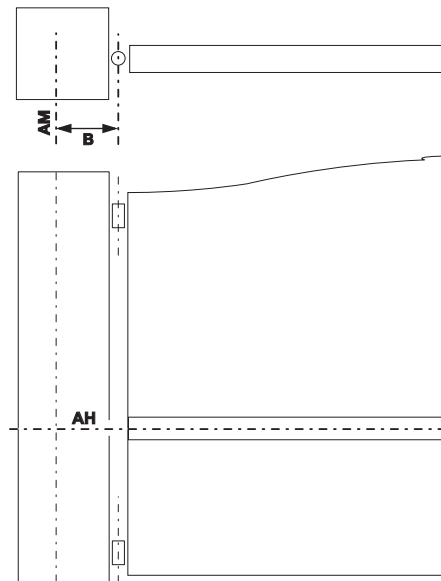

Zelfcontrole voor de volgende stap
Zijn de assen AM en AH goed afgetekend?

► In de palen boren

1

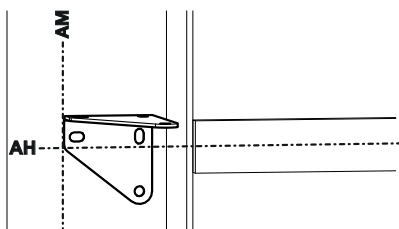

Breng de merktekens die zijn afgetekend op de beugel op een lijn met de as AH en breng de rand van de beugel op een lijn met de as AM.

N.B.: De merktekens op de beugels bevinden zich onder de sleufvormige gaten.



Positioneer de beugel in de richting e of E die is bepaald in stap 2 bij het meten (zie pagina 12).

Paal links

Paal rechts

Richting E

Richting e

Richting e

Richting E

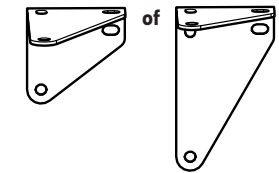
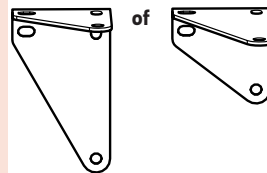

Let op de montagerichting omhoog en omlaag van de beugel.

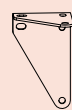

Goede richting

Foute richting

2

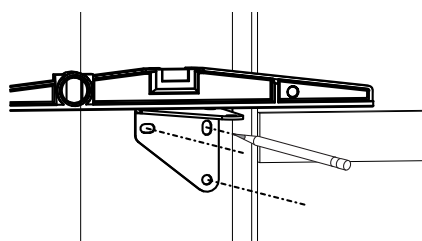

Controleer of de beugel horizontaal is en markeer daarna de bevestigingsgaten van de beugel.

3

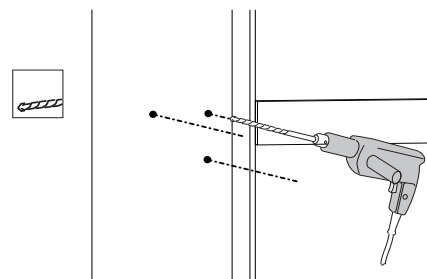

Boor 3 gaten in elke paal op de gemarkeerde plaatsen (zie pagina 11 voor de boordiameter die past bij de gebruikte bevestigingsmiddelen).

► De bevestigingsbeugel aan de paal bevestigen

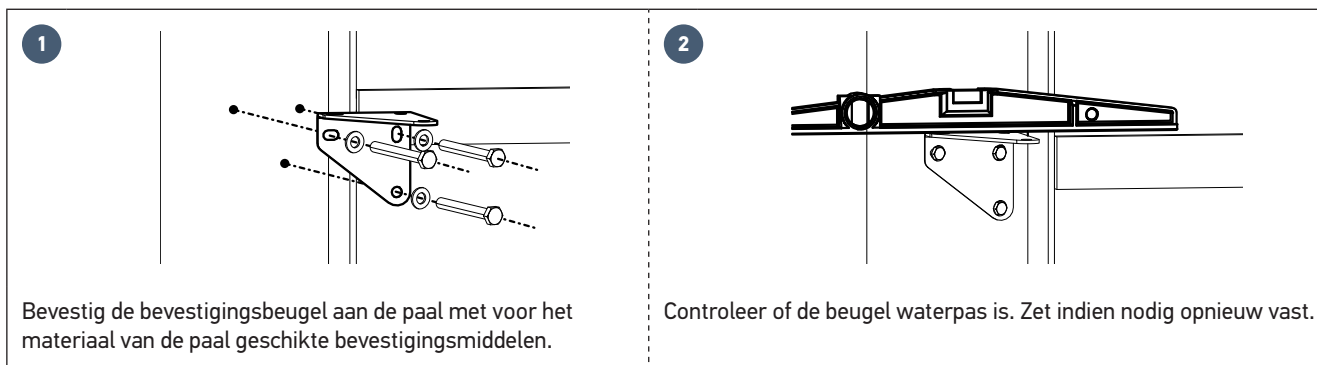

Zelfcontrole voor de volgende stap

Hebt u gecontroleerd of de beugels op de palen perfect horizontaal zijn?

► Monteer de werkcilinder op de bevestigingsbeugel.

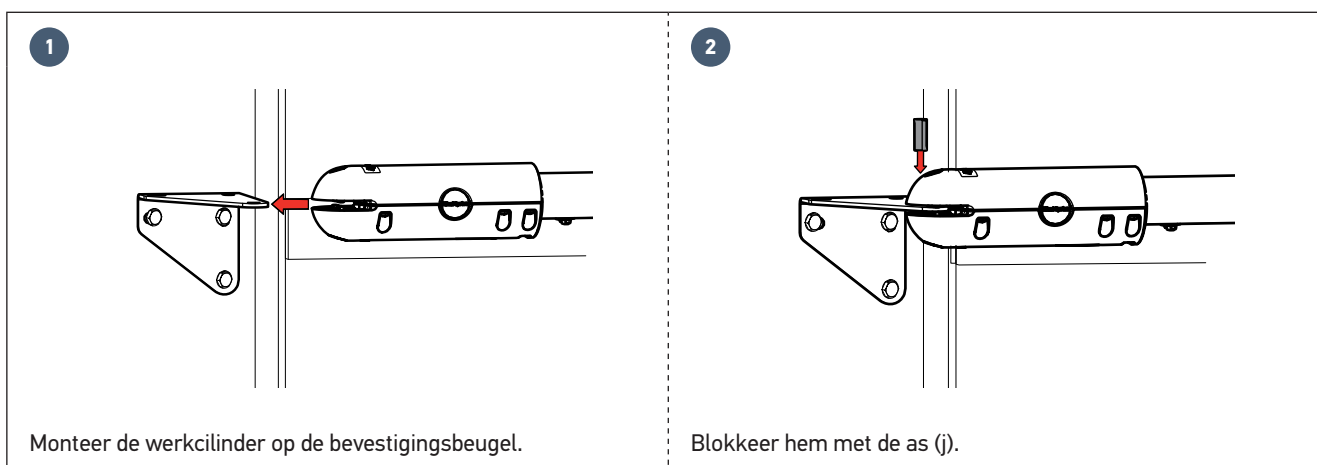





1.3 Bevestiging van de motoren aan de vleugels

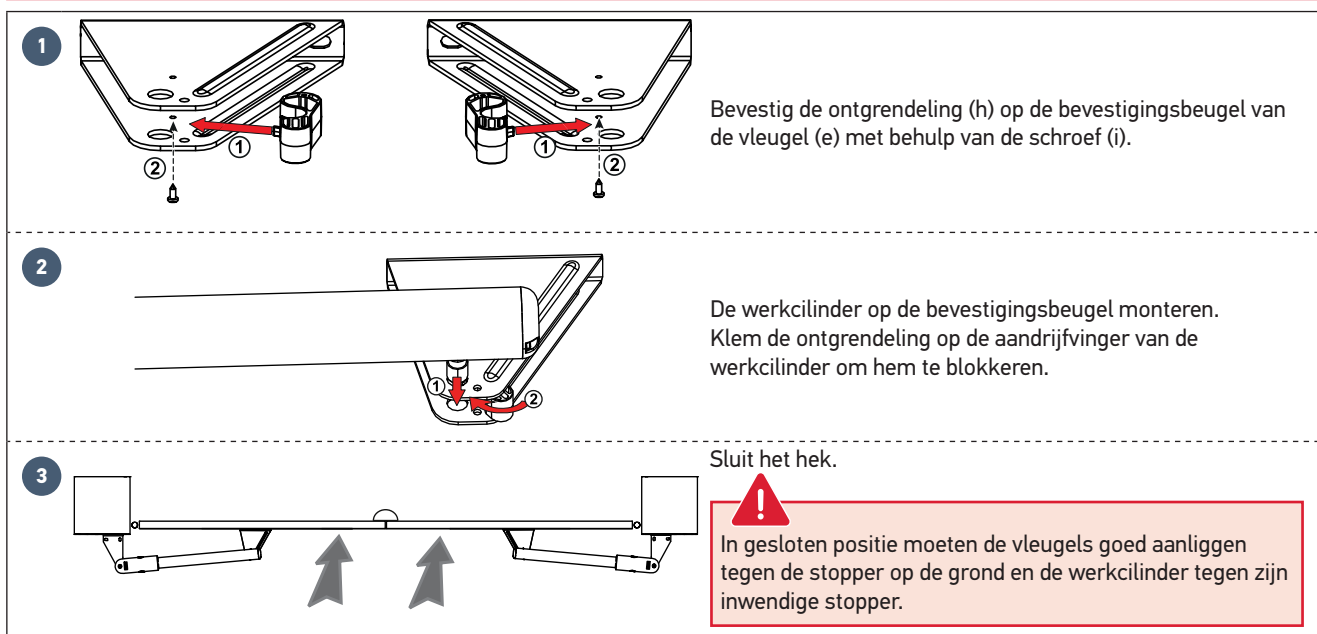

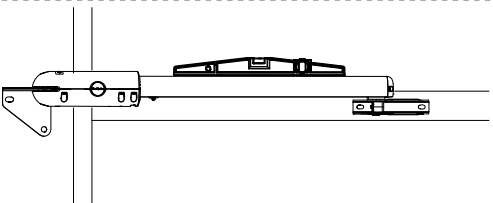
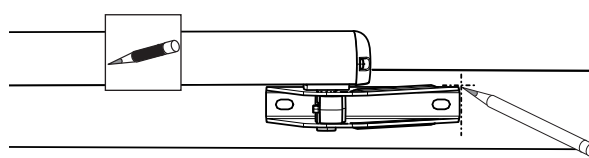
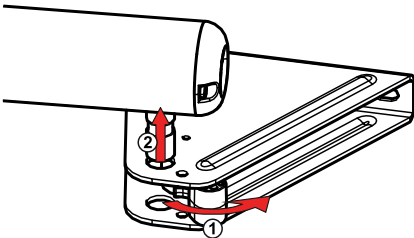
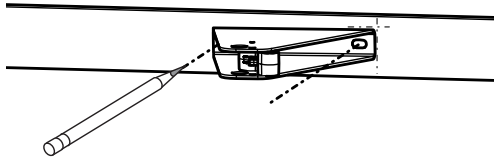
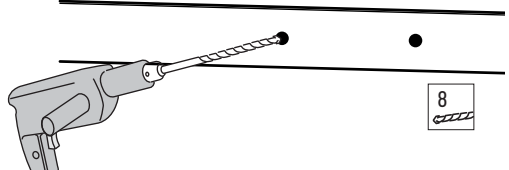
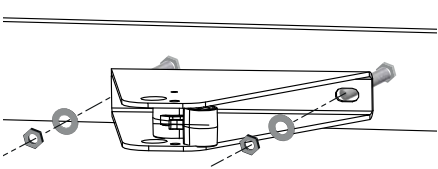
Laat de werkcilinder nooit werken voordat de bevestiging ervan op de vleugel klaar is. Anders kan de inwendige stopper in de werkcilinder ontregeld raken waardoor de goede werking niet langer gegarandeerd is.

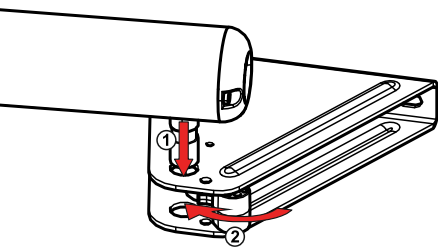

<p>4</p>		<p>Druk de bevestigingsbeugel van de vleugel tegen de versterking van de vleugel. Controleer of de werkcilinder horizontaal is.</p>
<p>5</p>		<p>Markeer de merktekens op de zijkanten van de versterking van de vleugel.</p>
<p>6</p>		<p>Maak de ontgrendeling los en verwijder de werkcilinder uit de bevestigingsbeugel van de vleugel.</p>
<p>7</p>		<p>Positioneer de bevestigingsbeugel van de vleugel opnieuw en markeer de bevestigingsgaten in het midden van de sleufvormige gaten.</p>
<p>8</p>		<p>Boor gaten in de vleugels met diameter 8.</p>
<p>9</p>		<p>Bevestig de bevestigingsbeugel van de vleugel op de twee punten op de vleugel met schroeven die geschikt zijn voor het materiaal van de versterking en de meegeleverde ringen (k).</p> <div style="border: 1px solid red; padding: 5px; margin-top: 10px;"> <p> Het monteren van de meegeleverde ringen (k) is verplicht.</p> </div>
<p>10</p>		<p>Installeer de werkcilinder. Klem de ontgrendeling op de aandrijfvinger om hem te blokkeren.</p>

 **Zelfcontrole voor de volgende stap**
Hebt u gecontroleerd of de werkcilinders perfect horizontaal zijn?

1.4 Installatie van de bedieningseenheid

► Positie van de bedieningseenheid

De kast moet worden gemonteerd op een paal/muur aan de aanvoerkant van de elektrische voeding.

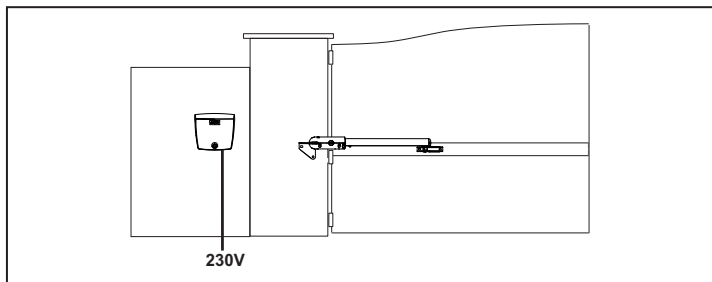

► De afdichtstrook installeren

Druk de afdichtstrook (m) in de bovenkant van de bedieningseenheid.

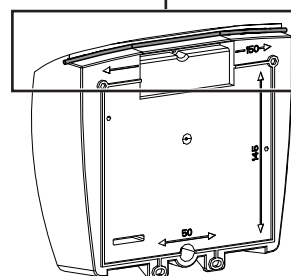
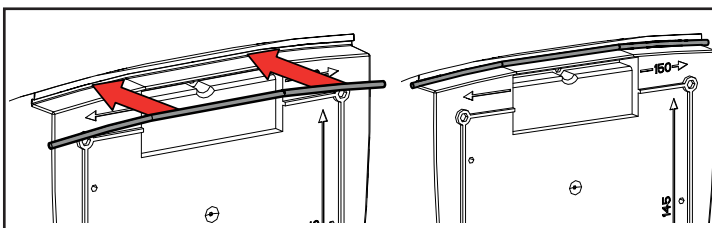

► De positie van de antenne controleren

De goede plaatsing van de antenne is essentieel voor een optimale werking.



Snijd de antennendraad nooit af.

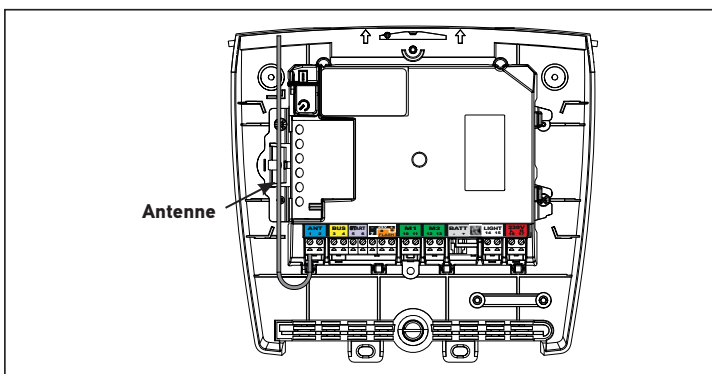

► De bedieningseenheid bevestigen

<p>1</p>	<ul style="list-style-type: none"> • Plaats het bevestigingshoekstuk van de kast (p) tegen de paal/muur. • Controleer of deze horizontaal is door een waterpas op de daarvoor bestemde plaats te leggen. • Markeer de bevestigingspunten van het hoekstuk.
<p>2</p>	<p>Verwijder het hoekstuk en boor gaten in de paal/muur. De diameter van de boorgaten is afhankelijk van het gebruikte type bevestigingsschroeven (zie pagina 11).</p>

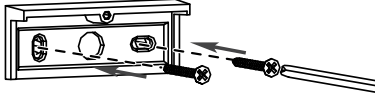
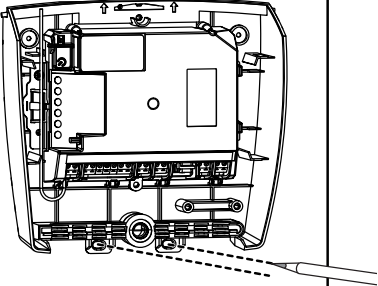
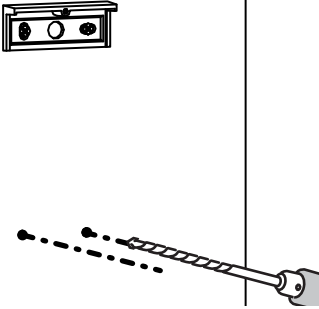
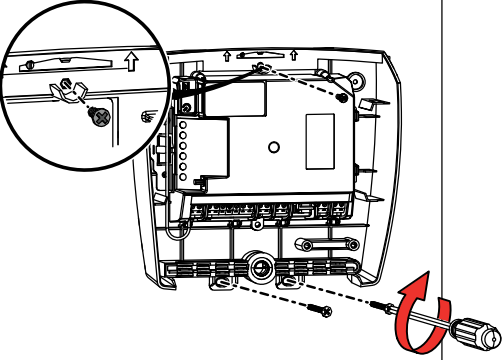
<p>3</p>		<p>Monteer het hoekstuk tegen de paal/muur.</p>
<p>4</p>		<p>Plaats de bodem van de kast om de 2 onderste bevestigingspunten van de kast te markeren.</p>
<p>5</p>		<p>Verwijder de bodem van de kast en boor gaten in de paal/muur. De diameter van de boorgaten is afhankelijk van het gebruikte type bevestigingsschroeven (zie pagina 11).</p>
<p>6</p>		<p>Monteer de bodem van de kast tegen de paal/muur: 1 schroef (q) om de kast aan het hoekstuk vast te zetten + 2 schroeven om de kast aan de paal/muur vast te zetten.</p>

1.5 Aansluiten van de motoren



De motor M1 bedient de vleugel die:

- als eerste open gaat en als laatste sluit,
- open gaat voor de voetgangersopening van het hek.

1

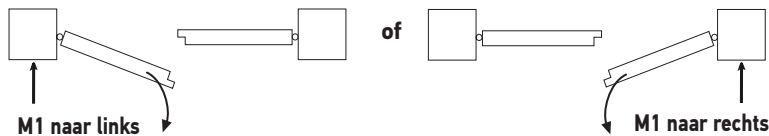

Hek dicht, bepaal welke vleugel als eerste moet openen.
De motor M1 bedient deze vleugel.

2

Sluit de motoren aan zoals aangegeven in onderstaande tabel:

Sluit de draad van de motor	aan op de klem	
...	...	
M1	blauw	10
	bruin	11
M2	blauw	12
	bruin	13

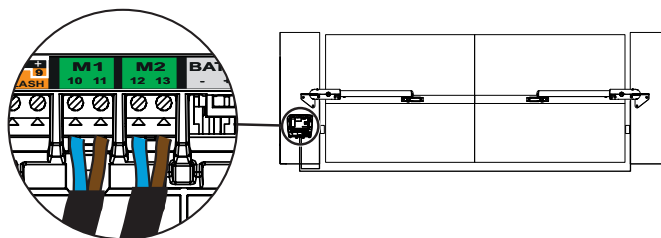

1.6 Aansluiten op de netvoeding



Voor uw veiligheid moeten deze werkzaamheden zonder spanning worden uitgevoerd.

Gebruik een kabel 3 x 1,5 mm² voor buitengebruik (ten minste type H07RN-F).

Verplicht de meegeleverde kabelklem gebruiken. Zorg ervoor dat alle laagspanningskabels bestand zijn tegen een trekkracht van 100 N.

Controleer of de draden niet verplaatst zijn na het toepassen van deze kracht.

1



Bereid op een kabel van type 3 x 1,5 mm², 2 draden van 4 cm voor (fase en nul).

2

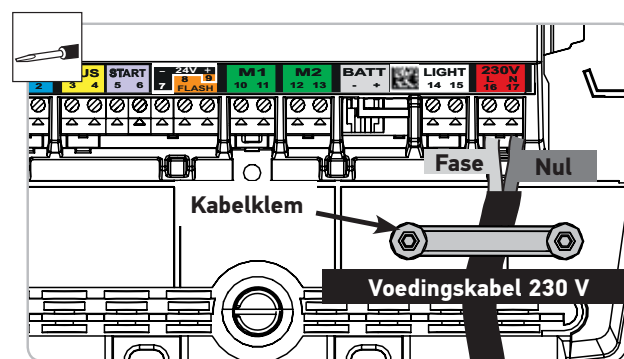

- Sluit de fase en de nul aan op de klemmen 16 en 17 (rode sticker "230 V").
- Blokkeer de 230 V-voedingskabel met de meegeleverde kabelklem (r).
- Plaats een kroonsteentje op de aardingsdraad (geel/groen) en berg deze op in de bedieningskast.

2.1 De spanning inschakelen op de installatie

De led  knippert (2 keer).

De motorisatie krijgt spanning en wacht op de zelfprogrammering.

Als de led  niet gaat branden of het aantal knippersignalen niet volgens verwachting is: zie "Diagnose" pagina 31.

2.2 Instelling van de openingsstopper



Openingsstoppers

De openingsstoppers zijn ingebouwd in de werkcilinder. Zij begrenzen de slag van het hek bij het openen.

Opmerking: De installatie moet zijn voorzien van op de grond bevestigde sluitstoppers die de slag van het hek begrenzen bij het sluiten.

Tijdens deze fase zorgt een druk op de toets 1 van de geprogrammeerde afstandsbediening alleen voor het openen en het stoppen van het hek (1e druk = openen, 2e druk = stoppen, 3e druk = openen, 4e druk = stoppen, enz.). U kunt de gewenste openingspositie op deze manier in een aantal stappen instellen. De sluiting van het hek is pas mogelijk nadat de openingsstoppers zijn ingesteld.

1		<ul style="list-style-type: none"> • Druk op de toets 1 van de afstandsbediening. Na enkele seconden gaat de eerste vleugel langzaam open. Als de vleugel niet opengaat, controleer dan of de motoren zijn bekabeld zoals aangegeven op pagina 18. • Druk opnieuw op de toets 1 van de afstandsbediening om de vleugel te stoppen op de gewenste openingspositie.
2		<p>Positioneer de openingsstopper tegen de koppeling van de werkcilinder en zet de stoppers vast met een inbusleutel diameter 3 (2 schroeven per stopper).</p> <div style="border: 1px solid red; padding: 5px;"> <p> Draai de sleutel 2 omwentelingen na het eerste contact.</p> </div>
3		<p>Druk op de toets 1 van de afstandsbediening. De tweede vleugel gaat open.</p>
4		<p>Druk opnieuw op de toets 1 van de afstandsbediening om de vleugel te stoppen op de gewenste openingspositie.</p>

5

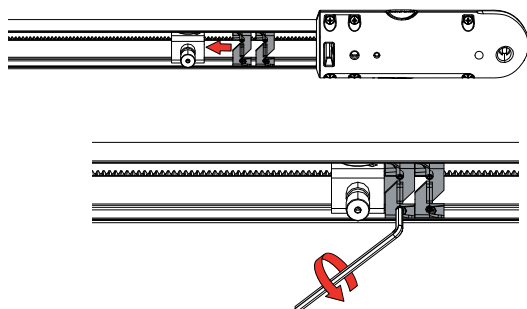

Positioneer de openingsstopper tegen de koppeling van de werkcilinder en zet de stoppers vast met een inbussleutel diameter 3 (2 schroeven per stopper).



Draai de sleutel 2 omwentelingen na het eerste contact.

6

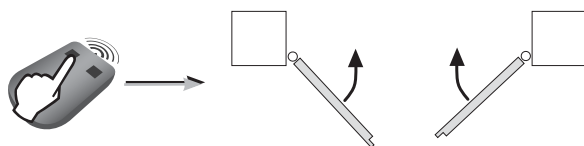

Druk op de toets 1 van de afstandsbediening om het hek volledig te sluiten. De vleugels sluiten na elkaar.



Zelfcontrole voor de volgende stap

Hebt u de positie van de openingsstopper op elke motor ingesteld?

2.3 Zelfprogrammering van de slag van het hek

Controleer of de installatie is ingeschakeld: de led  knippert (2 keer).

Situatie 1: Eerste ingebruikname van de motorisatie

Druk op de toets 1 van de afstandsbediening om het COMPLEET openen van het hek te starten.

Als het hek compleet open is, druk opnieuw op de toets 1 van de afstandsbediening om het COMPLEET sluiten van het hek te starten.

Als het hek compleet gesloten is, moet de led  van de bedieningseenheid CONTINU BRANDEN.

Situatie 2: U hebt de instellingen gewist

Laat het hek 4 keer compleet openen en sluiten.

Na de 4 bewegingen moet de led  van de bedieningseenheid CONTINU BRANDEN.

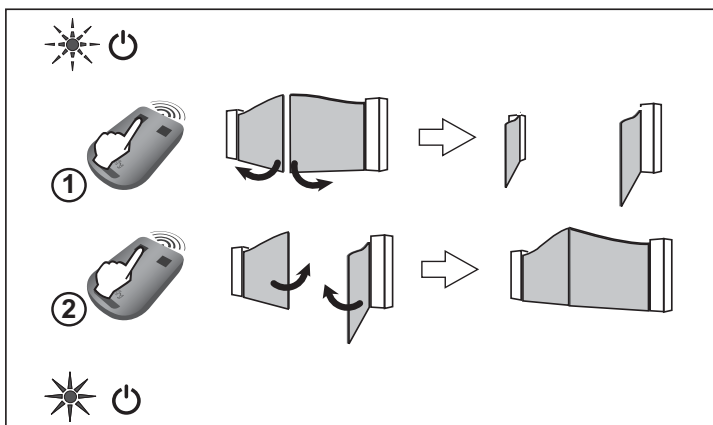

De bewegingen van het hek mogen niet worden onderbroken (compleet openen/sluiten). Als deze zijn onderbroken, begint het inleren automatisch bij de volgende openingsopdracht.

Als de led  knippert, start dan de opnieuw zelfprogrammering van de slag van de vleugels (4 keer compleet openen en sluiten).

Als de led  blijft knipperen, raadpleeg dan "Diagnose" pagina 31.

Als het hek weer opengaat na het sluiten, zet dan de beugels van de vleugels los en verplaats ze een stukje naar het midden van het hek.



WAARSCHUWING

Na de installatie verplicht controleren of de obstakeldetectie werkt conform bijlage A van de norm EN 12 453.

2.4 De bedieningseenheid sluiten

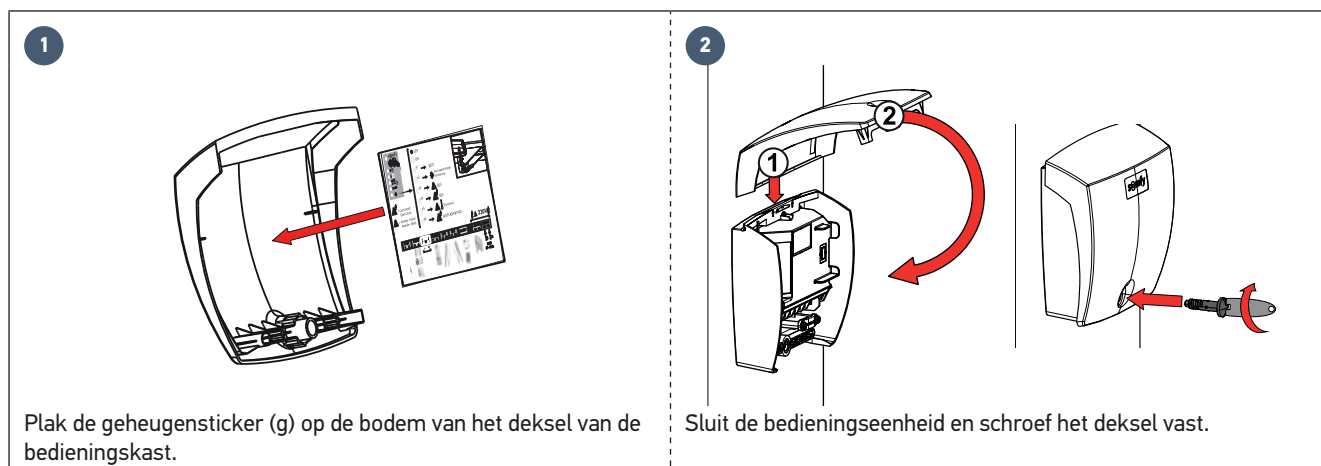

2.5 Stand-by/Wekken van de bedieningselektronica



Wanneer de zelfprogrammering is voltooid, gaat de elektronica automatisch in stand-by na 5 minuten van inactiviteit, om energie te besparen. In stand-by zijn alle lampjes uit.

Om te controleren of de motorisatie is ingeschakeld of om de instellingen te controleren of te wijzigen, drukt u 2 seconden op de knop  om de elektronica uit stand-by te halen. De elektronica gaat automatisch in stand-by na 5 minuten inactiviteit.

2.6 Geheel openen en sluiten van het hek



De in de set meegeleverde afstandsbedieningen zijn al geprogrammeerd zodat toets 1 van de afstandsbedieningen het totaal openen van het hek bedient.

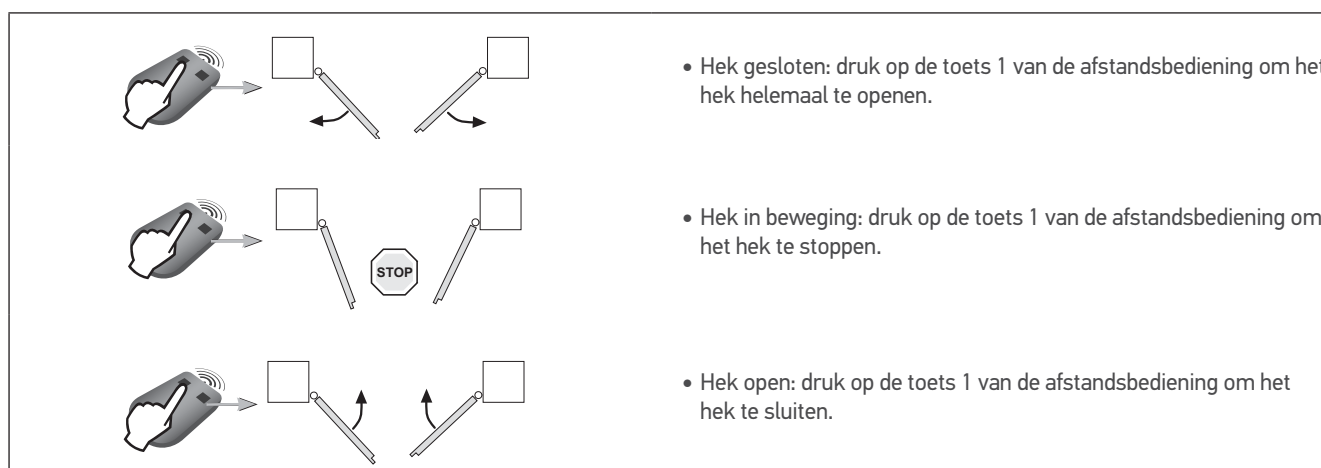
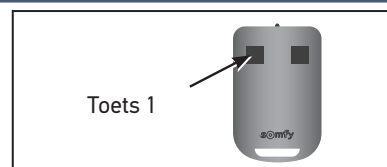

2.7 Detectie van obstakel

Als een obstakel gedetecteerd wordt (abnormale kracht op de motor):

- Tijdens het openen van het hek: het hek stopt.
- Tijdens het sluiten van het hek: het hek stopt en gaat opnieuw open.

2.8 Informatie van de gebruikers

Informeer altijd alle gebruikers over het veilig gebruiken van dit hek (standaard gebruik en ontgrendelingsprincipe) en over de verplichte periodieke controles.



Voor uw veiligheid moeten deze werkzaamheden zonder spanning worden uitgevoerd.



Het wordt aanbevolen om een zelfprogrammering uit te voeren voor de slag van het hek, voordat de accessoires (foto-elektrische cellen, knipperlicht enz.) worden aangesloten.

3.1 Foto-elektrische cellen



Er kan geen tweede set foto-elektrische cellen worden aangesloten op deze motor.

► Installatie

Na het aansluiten van de foto-elektrische cellen:

- schakel de motor weer in,
- het hek laten openen of sluiten.

De foto-elektrische cellen worden herkend door de bedieningselektronica na deze beweging.

► Werking met foto-elektrische cellen

Als de cellen worden afgedekt tijdens het sluiten van het hek, stopt het hek en gaat het weer open.

► In geval van het verwijderen van de foto-elektrische cellen

Na het verwijderen van de foto-elektrische cellen moet u de motor onder spanning zetten en daarna de procedure "Het automatisch sluiten deactiveren" pagina 26, uitvoeren.

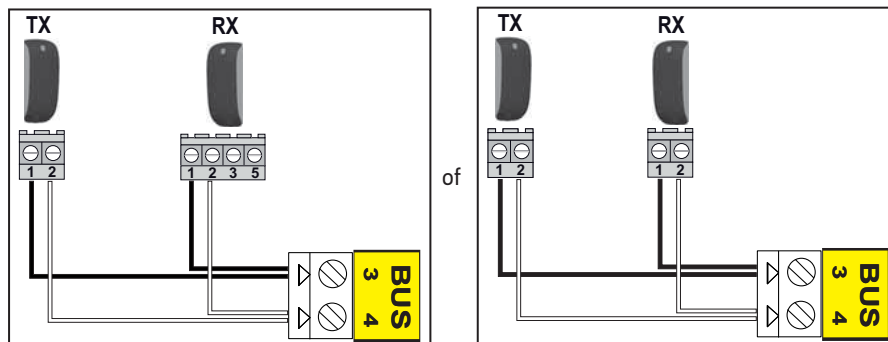

3.2 Knipperlicht



Lamp max. 10 W - 24 V - Door het gebruik van een lamp met een vermogen van meer dan 10 W - 24 V kan uw motorisatie defect raken.

► Werking van het knipperlicht

Het licht knippert tijdens wanneer het hek in beweging is.

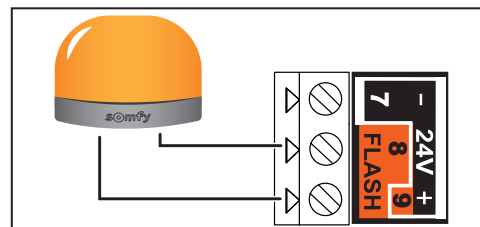

3.3 Accu (optie)



Dit accessoire kan niet worden gebruikt in combinatie met een zonne-energievoeding.



Om de duur van de werking op de accu te verlengen, zijn de per draad gevoede bedieningspunten uitgeschakeld; alleen de afstandsbedieningen en de draadloze bedieningspunten kunnen het hek bedienen.

De noodaccu zorgt ervoor dat het hek kan werken als er een stroomstoring is.

De led  knippert (1 keer) als de motor op de accu werkt.

► Technische gegevens van de accu

- Zelfstandigheid: 10 cycli continu of 24 uur op een hek dat in perfecte staat verkeert.
- Oplaadduur voor een optimaal gebruik van de accu: 48 uur.
- Levensduur: 3 jaar.

Voor een optimale levensduur van de accu, schakelt u de elektrische voeding van uw hek 3 keer per jaar uit om het een paar cycli op de accu te laten werken.

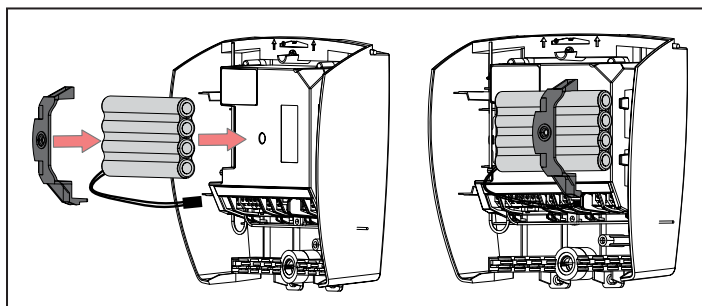

3.4 Aparte antenne (optie)



De draadantenne kan worden vervangen door een aparte antenne met een groter bereik.

Deze moet vrijstaand worden gemonteerd boven op de pilaar.

Deze wordt aangesloten op de klemmen 1 en 2 (blauw etiket "ANT") van de bedieningseenheid:

- de kern van de draad op klem 1,
- de massa-afscherming op klem 2.

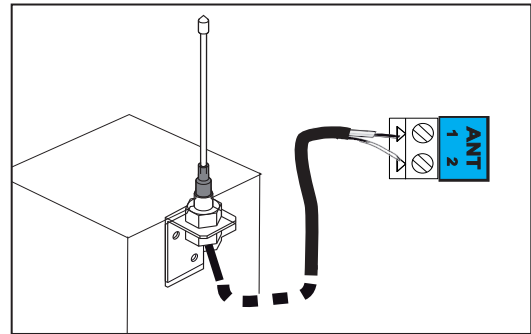

3.5 Videofoon (optie)



Dit accessoire kan niet worden gebruikt in combinatie met een zonne-energievoeding.

Sluit niet meer dan één spanningsvrij contact aan.

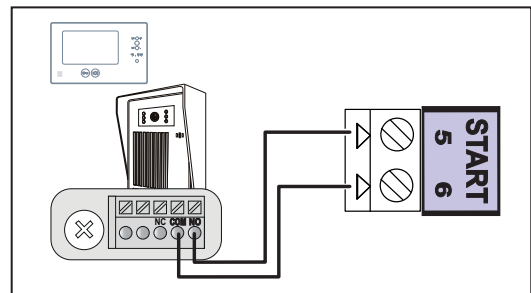

3.6 Contactslot (optie)



Dit accessoire kan niet worden gebruikt in combinatie met een zonne-energievoeding.

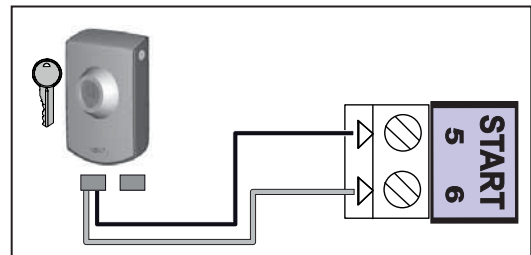

3.7 Zoneverlichting (optie)



Dit accessoire kan niet worden gebruikt in combinatie met een zonne-energievoeding.

Gebruik uitsluitend halogeenlampen of gloeilampen voor de verlichting van het gebied, maximaal 500 W.

► Werking van de zoneverlichting

Telkens als de motor in werking komt gaat de zoneverlichting branden. Deze gaat automatisch uit na 1,5 minuut na de beweging.

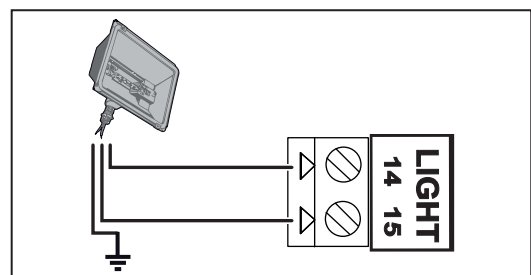

3.8 Zonne-energievoeding (optie)



De motor nooit aansluiten op een 230 V voeding als de motor is aangesloten op een zonne-energievoeding. Hierdoor kan de elektronica van de motor worden beschadigd.

Als de motor werkt op zonne-energievoeding:

- alleen de afstandsbedieningen en draadloze bedieningspunten kunnen het hek besturen (de bedrade bedieningspunten zijn gedeactiveerd),
- de bedrade veiligheidsaccessoires (foto-elektrische cellen, knipperlicht) blijven geactiveerd.

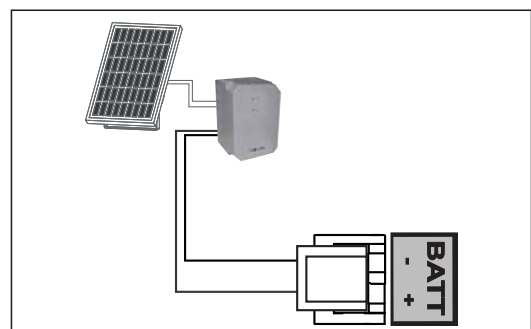

4.1 Voetgangersopening

► Werking van de voetgangersopening

<p>Voetgangersopening (motor M1) door een druk op de geactiveerde toets.</p>	
<p>Stoppen tijdens de beweging door een nieuwe druk op de geactiveerde toets.</p>	
<p>Sluiten door een nieuwe druk op de geactiveerde toets.</p>	

► De voetgangersopening activeren

i Toets 1 van afstandsbedieningen 2 of 4 toetsen kan niet worden geprogrammeerd voor het openen van de voetgangersopening van het hek.
Zie "Presentatie van de afstandsbedieningen" pagina 27 voor meer informatie.

<p>1</p> <p>Druk 2 sec op de knop van de bedieningselektronica. De led gaat branden.</p>	<p>2</p> <p>De nieuwe te programmeren afstandsbediening op het richtpunt van de bedieningselektronica plaatsen.</p>	<p>3</p> <p>Druk op de toets 2 van de afstandsbediening. De leds "RADIO" en gaan branden en gaan weer uit. De voetgangersopening is geactiveerd op deze toets.</p>
---	--	---

i Verwijder u van de bedieningselektronica om de voetgangersopening te testen.

► De voetgangersopening deactiveren

Herhaal de procedure "De voetgangersopening activeren" met de toets waarmee de voetgangersopening moet worden gedeactiveerd. De led gaat branden en gaat uit. De voetgangersopening is gedeactiveerd op deze toets.

4.2 Automatische sluiting

► Werking van het automatisch sluiten

Druk op de toets 1 van de afstandsbediening om het hek te openen.









Het hek gaat opnieuw dicht na 30 seconden of 5 seconden als er iets of iemand langs de foto-elektrische cellen komt.

Het automatisch sluiten van het hek kan worden onderbroken door toets 1 van de afstandsbediening in te drukken. Druk op toets 1 van de afstandsbediening om het hek vervolgens te sluiten.

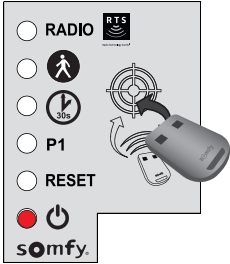
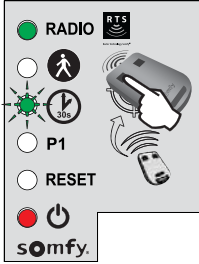

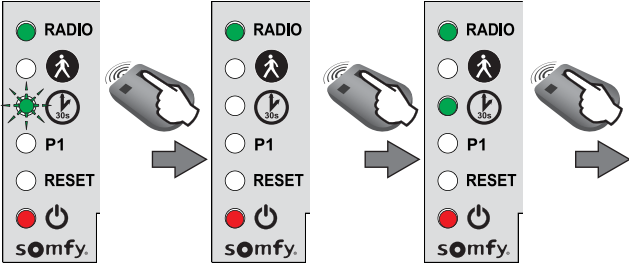

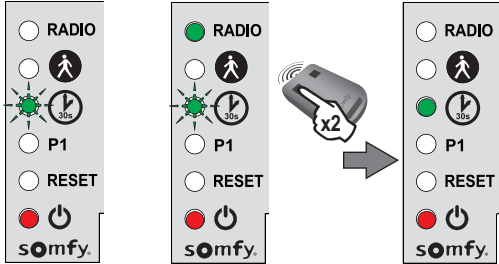



► Het automatisch sluiten activeren

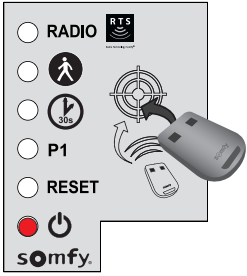
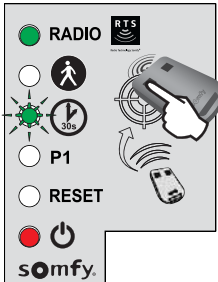

Het automatisch sluiten kan alleen worden geactiveerd als de foto-elektrische cellen zijn aangesloten en worden herkend door de bedieningselektronica van de motor.

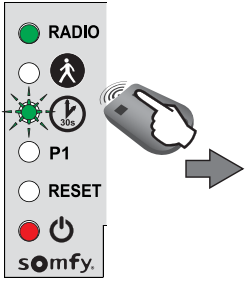
<p>1</p>  <p>Druk 2 sec op de knop  van de bedieningselektronica. De led  gaat branden.</p>	<p>2</p>  <p>De nieuwe te programmeren afstandsbediening op het richtpunt van de bedieningselektronica plaatsen.</p>	<p>3</p>  <p>Houd toets 1 van de afstandsbediening ingedrukt totdat de led  knippert.</p> <div data-bbox="1171 770 1410 1032" style="border: 1px solid orange; padding: 5px; margin-top: 10px;"> <p>i</p> <p>Na stap 3 kunt u de volgende stappen op afstand doen (zonder dat de afstandsbediening op het richtpunt ligt).</p> </div>
<p>4</p>  <p>Houd toets 2 van de afstandsbediening ingedrukt totdat de led  uitgaat en continu brandt.</p>		<p>5</p>  <p>Wanneer toets 2 wordt losgelaten, knippert de led , druk 2 keer op toets 1 van de afstandsbediening. De led  blijft branden. Het automatisch sluiten is geactiveerd.</p>

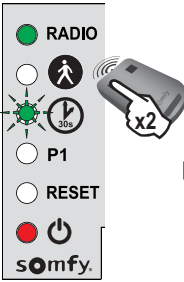
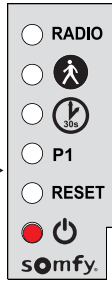
▶ Het automatisch sluiten deactiveren

<p>1</p>  <p>Druk 2 sec op de knop  van de bedieningselektronica. De led  gaat branden.</p>	<p>2</p>  <p>De nieuwe te programmeren afstandsbediening op het richtpunt van de bedieningselektronica plaatsen.</p>	<p>3</p>  <p>Houd toets 1 van de afstandsbediening ingedrukt totdat de led  knippert.</p>
<p>4</p>  <p>Druk op de toets 2 van de afstandsbediening. De led  knippert.</p>	<p>5</p>  <p>Druk 2 keer op toets 1 van de afstandsbediening.</p>	<p>6</p>  <p>De led  is uit. Het automatisch sluiten is gedeactiveerd.</p>

5.1 Presentatie van de afstandsbedieningen

De RTS afstandsbedieningen van Somfy kunnen, afhankelijk van de instellingen, de volgende handelingen bedienen:

- totale opening van het hek
- voetgangersopening van het hek
- een ander Somfy RTS apparaat (bijvoorbeeld: garagedeurmotor, rolluik, enz.)

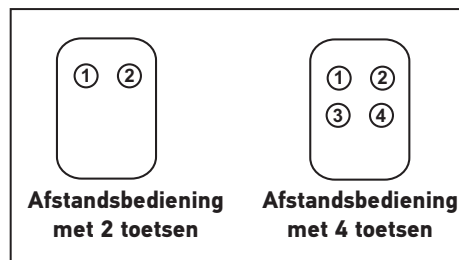

De in de set meegeleverde afstandsbedieningen zijn al geprogrammeerd zodat toets 1 van de afstandsbedieningen het totaal openen van het hek bedient.



U kunt maximaal 16 bedieningspunten opslaan (afstandsbedieningen, andere radiografisch bedieningspunt). Als u een 17e bedieningspunt opslaat, wordt het eerste automatisch gewist.



Als u een voetgangersopening wilt programmeren, moet deze verplicht in de toets worden geprogrammeerd na die van de totale opening (bijv.: totale opening bediend door toets 2, voetgangersopening bediend door toets 3). De voetgangersopening kan niet op de toets 1 van de afstandsbedieningen worden geprogrammeerd.

► Programmeringsmogelijkheden met de afstandsbediening met 2 toetsen

	1-toets	2-toets
Optie 1	Totaal openen	Voetgangersopening of andere Somfy RTS sturing
Optie 2	Andere Somfy RTS apparatuur	Totaal openen

► Programmeringsmogelijkheden met de afstandsbediening met 4 toetsen

	1-toets	2-toets	3-toets	4-toets
Optie 1	Totaal openen	Voetgangersopening of andere Somfy RTS sturing	Andere Somfy RTS sturing	Andere Somfy RTS sturing
Optie 2	Andere Somfy RTS sturing	Totaal openen	Voetgangersopening of andere Somfy RTS sturing	Andere Somfy RTS sturing
Optie 3	Andere Somfy RTS sturing	Andere Somfy RTS sturing	Totaal openen	Voetgangersopening of andere Somfy RTS sturing
Optie 4	Andere Somfy RTS sturing	Andere Somfy RTS sturing	Andere Somfy RTS sturing	Totaal openen

► Gebruik van een afstandsbediening met 3 toetsen



Openen

Druk op de op toets "Op" van de afstandsbediening om het hek te volledig te openen.

Stop

Druk op de middelste toets van de afstandsbediening om het hek te stoppen wanneer het in beweging is.

Sluiten

Druk op de toets "Neer" van de afstandsbediening om het hek te sluiten.



De afstandsbediening met 3 toetsen kan niet worden gebruikt om de motorinstellingen te wijzigen.

5.2 Een afstandsbediening toevoegen

► Afstandsbediening met 2 of 4 toetsen

<p>1</p>  <p>Druk 2 sec op de knop  van de bedieningselektronica. De led  gaat branden.</p>	<p>2</p>  <p>Plaats de nieuwe te programmeren afstandsbediening op het richtpunt van de bedieningselektronica.</p>	<p>3</p>  <p>Druk kort op de toets van de afstandsbediening die u wilt programmeren. De led "RADIOGRAFISCH" gaat branden en gaat uit wanneer u de toets van de afstandsbediening los laat. De totale opening is geprogrammeerd op deze toets.</p>
---	--	--

► Afstandsbediening met 3 toetsen

<p>1</p>  <p>Druk 2 sec op de knop  van de bedieningselektronica. De led  gaat branden.</p>	<p>2</p>  <p>Plaats de nieuwe te programmeren afstandsbediening op het richtpunt van de bedieningselektronica.</p>	<p>3</p>  <p>Druk kort op de toets van de afstandsbediening die u wilt programmeren. De led "RADIOGRAFISCH" gaat branden en gaat uit wanneer u de toets van de afstandsbediening los laat. De afstandsbediening is geprogrammeerd.</p>
--	---	--

5.3 De afstandsbedieningen wissen

Zie "Wis de instellingen" pagina 30.







De motorisatie moet zijn losgemaakt van alle voedingsbronnen gedurende het schoonmaken, het onderhoud en tijdens het vervangen van onderdelen.

6.1 Assistentie

Als het probleem niet verholpen is, bij een ander probleem of bij vragen over de gemotoriseerde aandrijving, gaat u voor hulp naar www.somfy.com.

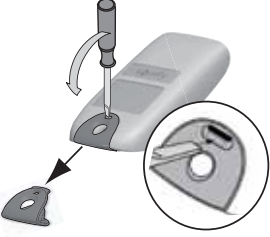
6.2 De batterij van de afstandsbediening vervangen

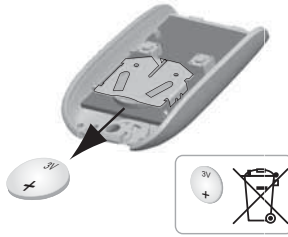





De batterij heeft een levensduur van ongeveer 2 jaar.

<p>1</p> 	<p>2</p> 	<p>3</p> 	<p>4</p> 
<p>Verwijder het klemmetje van de afstandsbediening.</p>	<p>Steek de schroevendraaier in de gleuf en til de kap op.</p>	<p>Verwijder de batterij met behulp van een schroevendraaier.</p>	<p>Vervang de batterij (3 V CR 2430 of CR 2032).</p>

6.3 Wis de instellingen

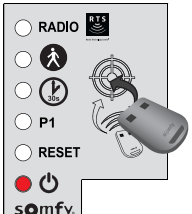
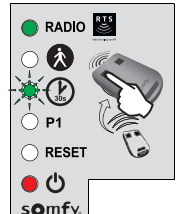
In welke gevallen wist u de instellingen?

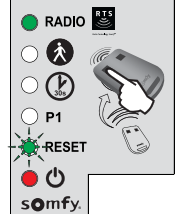
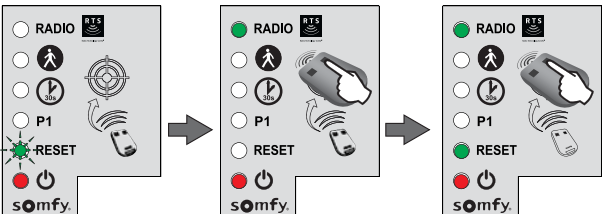
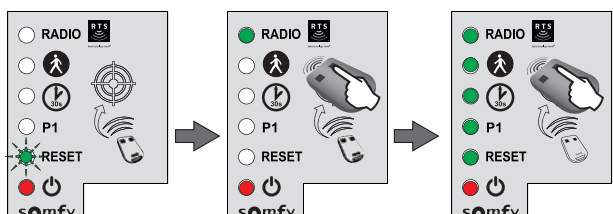
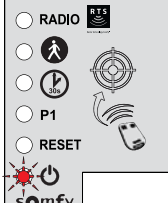
- Na het inleren van de slag van het hek, als u de aanslag open verplaatst of als u de aansluiting van de motoren verandert.
- Als het hek te pas en te onpas opent als gevolg van de normale slijtage van het hek.

<p>1</p>  <p>Druk 2 sec op de knop  van de bedieningselektronica. De led  gaat branden.</p>	<p>2</p>  <p>De geprogrammeerde afstandsbediening op het richtpunt plaatsen.</p>	<p>3</p>  <p>Houd toets 1 van de afstandsbediening ingedrukt totdat de led  knippert.</p>	<p>4</p>  <p>Druk 1 keer op toets 1 van de afstandsbediening. De led "RESET" knippert.</p>
<p>5 De instellingen wissen*</p>  <p>Houd toets 2 van de afstandsbediening ingedrukt totdat de led "RESET" brandt.</p>		<p>5 De afstellingen* en de afstandsbedieningen/ geprogrammeerde bedieningspunten wissen</p>  <p>Houd toets 2 van de afstandsbediening ingedrukt tot alle leds branden.</p>	
<p>6</p> 		<p>De led  knippert 2 keer (zie "Zelfprogrammering van de slag van het hek" pagina 20).</p>	



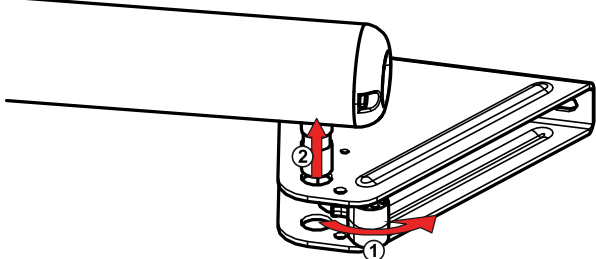
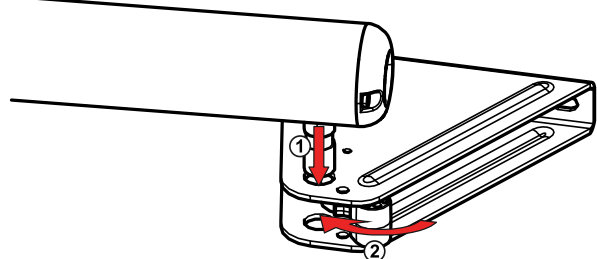

*Slag van het hek, deactivering van de instellingen, ...

6.4 De motoren ontgrendelen/vergrendelen

Door het ontgrendelen van de motoren, kan het hek met de hand worden bewogen als de stroom is uitgevallen.

<p>1</p>  <p>Ontgrendeling van de motoren Maak de ontgrendeling los en verwijder de werkcilinder uit de bevestigingsbeugel van de vleugel..</p>	<p>2</p>  <p>Vergrendeling van de motoren Installeer de werkcilinder. Klem de ontgrendeling op de aandrijfvinger om hem te blokkeren.</p>
--	---

6.5 Diagnose

DIAGNOSE		STORINGEN VERHELPEN
De motoren reageren niet op de commando's van de afstandsbediening	Te klein bereik van de afstandsbediening	<ul style="list-style-type: none"> - Controleer de batterij van de afstandsbediening (zie "Vervangen van de batterij van de afstandsbediening" pagina 29). - Controleer de antenne van de bedieningseenheid (aansluiting, positie, zie pagina 16). - Controleer of er geen externe elementen de radioverbinding verstoren (elektriciteitsmast, ijzeren wanden, enz.). Als dit het geval is, zorg dan voor een buitenantenne.
	Afstandsbediening is niet geprogrammeerd	Programmeer de afstandsbediening (zie pagina 28).
	Motoren niet goed aangesloten	Controleer de aansluiting van de motoren (zie pagina 18).
De led  van de bedieningsunit is uit	De elektronica is stand-by	Druk 2 seconden op de toets  om de elektronica uit stand-by te halen.
	Bedieningselektronica niet gevoed	<ul style="list-style-type: none"> - Controleer de netvoeding. - Controleer de voedingskabel.
De led  van de bedieningsunit knippert:		
knippert 1 keer	Werking op noodaccu	Controleer de netvoeding.
knippert 2 keer	Motor in afwachting van zelfprogrammering	Start de zelfprogrammering van de slag van het hek (zie pagina 20).
knippert 3 keer	Foto-elektrische cellen defect	<ul style="list-style-type: none"> - Controleer of er zich geen obstakel tussen de foto-elektrische cellen bevindt. - Controleer de uitlijning van de cellen. - Controleer de aansluiting van de cellen (zie pagina 22). - Als de cellen opzettelijk losgemaakt zijn, de procedure "Het automatisch sluiten deactiveren" pagina 26, uitvoeren.
knippert 4 keer	Permanent commando op de "START"-uitgang van de elektronicakast (klemmen 5-6)	Controleer de accessoires die zijn aangesloten op de START-uitgang van de bedieningseenheid.
knippert 5 keer	Thermische beveiliging van de elektronica geactiveerd	Laat de elektronica afkoelen tot de led  opnieuw continu brandt.
knippert 6 keer	Kortsluiting op de BUS-uitgang van de elektronicakast (klemmen 3-4)	Controleer de accessoires die zijn aangesloten op de BUS-uitgang van de elektronicakast.
	Kortsluiting op de 24 V-uitgang van de elektronicakast (klemmen 7-9)	Controleer het accessoire dat is aangesloten op de "24 V" uitgang van de elektronicakast.
	Kortsluiting "knipperlicht" in de elektronicakast (klemmen 8-9)	Controleer de aansluiting van het knipperlicht (zie pagina 22).
	Kortsluiting motor	Controleer de aansluiting van de motoren (zie pagina 18).
knippert 7 keer	Elektronische storing	Neem contact op met de helpdesk van Somfy.
Het hek gaat weer open na het sluiten		Zet de beugels van de vleugels los en verplaats deze een stukje naar het midden van het hek.

Voeding	230 V - 50 Hz / 24 V (op zonne-energie)
Type van de motor	24 V
Vermogen van de motor	120 W
Max. opgenomen vermogen (met zoneverlichting)	600 W
Verbruik stand-by	3 W (zonder accessoires)
Max. aantal bewegingen per dag	20 cycli/dag 10 cycli/dag op zonne-energie
Openingstijd	Minimaal 20 s tot 90°
Automatische detectie van obstakel	Conform norm EN 12 453
Werkings temperatuur	-20 °C tot +60 °C
Thermische bescherming	Ja
Beschermingsklasse	IP 44
Geïntegreerde radio-ontvanger	Ja
Afstandsbedieningen: - Radiofrequentie - Bereik - Op te slaan aantal	433,42 MHz, < 10 mW ~ 30 m 16
Mogelijke aansluitingen: - Knipperlichtuitgang - Uitgang verlichting - Uitgang voeding accessoires - Ingang voor noodbatterij - Ingang voor foto-elektrische cellen - Ingang van de bediening door spanningsloos contact	Knipperend, 24 V, max. 10 W max. 500 W bij 230 V (alleen halogeen of gloeilamp) 24 Vdc / max. 15 W Ja Ja Ja (werkt niet op accuvoeding of zonnecel)

Cuprins

Instrucțiuni de siguranță			
- Informații importante			
- Starea porții de acces de motorizat			
- Instalația electrică			
- Trecerea cablurilor			
- Instrucțiuni de siguranță privind instalarea motorizării			
- Instrucțiuni de siguranță privind utilizarea			
- Instrucțiuni de siguranță privind întreținerea			
- Indicații privind bateriile			
- Reciclarea și eliminarea			
- Reglementări			
- Prevenirea riscurilor			
Prezentarea produsului			
- Conținutul pachetului			
- Descrierea produsului			
- Gabaritul			
- Domeniul de aplicare			
- Vedere generală a instalației			
- Prezentarea sistemului electronic de comandă			
Cerințe prelabile pentru instalare			
- Aspecte de verificat înainte de instalare			
- Preechipare electrică			
- Cabluri de prevăzut			
- Scule necesare la instalare (nefurnizate)			
- Piese de fixare necesare la instalare (nefurnizate)			
1 Instalarea	12		
1.1 Măsurarea cotelor	12		
1.2 Fixarea suporturilor pe stâlp	13		
- Trasarea axelor AM și AH	13		
- Găurirea stâlpilor	13		
- Prinderea suportului de fixare pe stâlp	14		
- Montarea cilindrului pe suportul de fixare	14		
1.3 Fixarea motoarelor pe canaturi	14		
1.4 Instalarea unității de comandă	16		
- Poziția unității de comandă	16		
- Instalarea cordonului de etanșeitate	16		
- Verificarea poziției antenei	16		
- Fixarea unității de comandă	16		
1.5 Racordarea motoarelor	18		
1.6 Racordarea la alimentarea de la rețeaua electrică	18		
2 Punerea în funcțiune și modul de utilizare standard	19		
2.1 Punerea sub tensiune a instalației	19		
2.2 Reglarea opritorului de deschidere	19		
2.3 Autoînvățarea cursei porții de acces	20		
2.4 Închiderea unității de comandă	21		
2.5 Punerea în stare de veghe/Activarea sistemului electronic de comandă	21		
2.6 Deschiderea totală și închiderea porții de acces	21		
2.7 Detectarea obstacolelor	21		
2.8 Instruirea utilizatorilor	21		
2 3 Cablarea accesoriilor	22		
3.1 Celule fotoelectrice	22		
3.2 Lampă de semnalizare	22		
3.3 Baterie (opțional)	22		
3.4 Antenă de comandă la distanță (opțional)	23		
3.5 Videofon (opțional)	23		
3.6 Contactor cu cheie (opțional)	23		
3.7 Iluminarea zonei (opțional)	23		
3.8 Alimentare solară (opțional)	23		
4 Parametrizări avansate	24		
4.1 Deschidere pentru pietoni	24		
- Funcționarea deschiderii pentru pietoni	24		
- Activarea deschiderii pentru pietoni	24		
- Dezactivarea deschiderii pentru pietoni	24		
4.2 Închiderea automată	25		
- Funcționarea închiderii automate	25		
- Activarea închiderii automate	25		
- Dezactivarea închiderii automate	26		
5 Programarea telecomenzilor	27		
5.1 Prezentarea telecomenzilor	27		
- Opțiuni de programare a telecomenzii cu 2 taste	27		
- Opțiuni de programare a telecomenzii cu 4 taste	27		
- Utilizarea unei telecomenzi cu 3 taste	27		
5.2 Adăugarea unei telecomenzi	28		
- Telecomandă cu 2 sau 4 taste	28		
- Telecomandă cu 3 taste	28		
5.3 Ștergerea telecomenzilor	28		
6 Asistență la depanare	29		
6.1 Asistență	29		
6.2 Încărcarea bateriei telecomenzii	29		
6.3 Ștergerea reglajelor	30		
6.4 Deblocarea / blocarea motoarelor	30		
6.5 Diagnosticare	31		
7 Caracteristici tehnice	32		

► Instrucțiuni de siguranță

 Acest simbol indică un pericol ale cărui diferite grade de severitate sunt descrise mai jos.

PERICOL

Indică un pericol care poate provoca imediat răni grave sau decesul.

AVERTISMENT

Indică un pericol care poate provoca răni grave sau decesul.

PRECAUȚIE

Indică un pericol care poate provoca răni ușoare sau de gravitate medie.

ATENȚIE

Indică un pericol care poate deteriora sau distruge produsul.

AVERTISMENT

AVERTISMENTE - Instrucțiuni importante de siguranță.

Este important pentru siguranța persoanelor să se urmeze toate instrucțiunile deoarece o instalare incorectă poate provoca răni grave. Păstrați aceste instrucțiuni. Instalatorul trebuie să asigure obligatoriu instruirea tuturor utilizatorilor pentru a garanta o utilizare în condiții de maximă siguranță a motorizării, conform manualului de utilizare. Instrucțiunile trebuie să fie înmânate utilizatorului final.

► Informații importante

Acest produs este o motorizare pentru o poartă de acces batantă, pentru uz rezidențial, așa cum este definit în conformitate cu norma EN 60335-2-103. Aceste instrucțiuni au drept obiectiv, în special, satisfacerea exigențelor normelor respective și, astfel, garantarea siguranței bunurilor și a persoanelor.

AVERTISMENT

Orice utilizare a acestui produs în afara domeniului de aplicare descris în acest manual este interzisă (consultați paragraful „Domeniul de aplicare” din manual). Utilizarea oricărui accesoriu sau a oricărei componente nerecomandate de Somfy este interzisă - siguranța persoanelor nu ar fi garantată. Compania Somfy nu poate fi trasă la răspundere pentru pagube care rezultă din nerespectarea instrucțiunilor din acest manual.

În cazul în care aveți vreo îndoială în momentul instalării motorizării sau pentru a obține informații suplimentare, consultați site-ul internet www.somfy.com. Aceste instrucțiuni sunt susceptibile de a fi modificate în cazul evoluției normelor sau motorizării.

► Starea porții de acces de motorizat

Înainte de a instala motorizarea, verificați dacă:

- poarta de acces este în stare mecanică bună.
- poarta de acces este stabilă, indiferent de poziția sa.
- structurile care susțin poarta de acces permit fixarea solidă a motorizării. Ranforșați-le dacă este necesar.
- poarta de acces se închide și se deschide manual în mod convenabil cu o forță mai mică de 150 N.
- intervalul de temperatură marcat pe motorizare este adaptat la locul de amplasare.

ATENȚIE

Evitați stropirea motorizării cu apă.
Nu instalați motorizarea într-un mediu exploziv.

AVERTISMENT

Asigurați-vă că zonele periculoase (strivire, forfecare, înțepenire) dintre partea antrenată și părțile fixe înconjurătoare datorate mișcării de deschidere a părții antrenate sunt evitate sau indicate pe instalație (consultați „Prevenirea riscurilor”).

Fixați definitiv etichetele de avertizare împotriva strivirii într-un loc vizibil sau în apropierea eventualelor dispozitive fixe de comandă.

► Instalația electrică

PERICOL

Instalarea sursei de alimentare electrică trebuie să fie în conformitate cu normele în vigoare din țara în care este instalată motorizarea și trebuie efectuată de un personal calificat.

PERICOL

Linia electrică trebuie să fie rezervată exclusiv motorizării și trebuie să fie dotată cu o protecție care să cuprindă:

- o siguranță sau un disjuncter de calibrul 10 A,
- și un dispozitiv de tip diferențial (30 mA).

Trebuie prevăzut un mijloc de deconectare omnipolară de la alimentare. Întrerupătoarele prevăzute pentru a asigura întreruperea generală a aparatelor fixe trebuie să fie racordate direct la bornele de alimentare și trebuie să păstreze o distanță de separare față de contactele de la toți polii, pentru a asigura o deconectare completă în condițiile clasei III de supratensiune. Cablurile de joasă tensiune supuse intemperii trebuie să fie cel puțin de tip H07RN-F. Se recomandă instalarea unui paratrăsnet (tensiune reziduală maximă de 2 kV obligatorie).

► Trecerea cablurilor

PERICOL

Cablurile îngropate trebuie prevăzute cu o teacă de protecție cu un diametru suficient pentru trecerea cablului motorului și a cablurilor accesoriilor. Pentru cablurile neîngropate, utilizați un canal de cablu care va putea suporta trecerea vehiculelor (ref. 2400484).

► Instrucțiuni de siguranță privind instalarea motorizării

AVERTISMENT

Scoateți-vă bijuteriile (brățară, lanț sau altele) în momentul instalării. Pentru operațiile de manipulare, găurire și sudare, purtați protecțiile adecvate (ochelari speciali, mănuși, cască antifonică etc.).

PERICOL

Nu racordați motorizarea la o sursă de alimentare (de la rețea, baterie sau solară) înainte de a fi terminat instalarea.

AVERTISMENT

Este strict interzis să modificați unul dintre elementele furnizate în acest kit sau să utilizați un element suplimentar neprevăzut în acest manual.

Supravegheați poarta de acces în timpul mișcării și țineți persoanele la distanță până la terminarea instalării.

Nu utilizați adevizi pentru fixarea motorizării.

AVERTISMENT

Deblocarea manuală poate antrena o mișcare necontrolată a porții de acces. Fixați definitiv eticheta cu privire la dispozitivul de deblocare manuală aproape de organul său de manevră.

AVERTISMENT

Instalați orice dispozitiv de comandă fix la o înălțime de cel puțin 1,5 m și cu vedere directă spre poarta de acces, dar la distanță de părțile mobile.

După instalare, asigurați-vă că:

- mecanismul este reglat corect.
- dispozitivul de deblocare manuală funcționează corect.
- motorizarea își schimbă sensul de mișcare atunci când poarta de acces întâlnește un obiect de 50 mm poziționat la jumătatea înălțimii canatului.

AVERTISMENT

În cazul unei funcționări în mod automat sau al unei comenzi efectuate fără vedere la ușă, este obligatoriu să instalați celule fotoelectrice. Motorizarea în mod automat este cea care funcționează cel puțin într-o direcție fără activarea intenționată de către utilizator.

În cazul unei funcționări în mod automat sau dacă poarta de acces dă spre drumul public, instalarea unei lămpi de semnalizare poate fi obligatorie, în conformitate cu reglementarea din țara în care este pusă în funcțiune motorizarea.

► Instrucțiuni de siguranță privind utilizarea

AVERTISMENT

Această motorizare poate fi utilizată de către copii cu vârste de cel puțin 8 an și de către persoane ale căror capacități fizice, senzoriale sau mentale sunt reduse sau care sunt lipsite de experiența sau de cunoașterea necesare, exceptând cazul în care acestea sunt supravegheate în mod corespunzător sau dacă au putut beneficia de instrucțiuni referitoare la utilizarea motorizării în deplină siguranță și dacă riscurile întâmpinate au fost înțelese. Nu lăsați dispozitivele de comandă a porții la îndemâna copiilor. Nu lăsați telecomenzile la îndemâna copiilor. Curățarea și întreținerea nu trebuie să fie efectuate de către copii.

Nivelul de presiune acustică al motorizării este mai mic sau egal cu 70 dB(A). Zgomotul emis de structura la care va fi conectată motorizarea nu este luat în considerare.

AVERTISMENT

Orice utilizator potențial trebuie să primească o instruire în utilizarea motorizării de către instalator, prin aplicarea tuturor recomandărilor din acest manual. Este obligatoriu să vă asigurați că nicio persoană neinstruită nu poate pune poarta de acces în mișcare.

Utilizatorul trebuie să supravegheze poarta de acces în timpul mișcării și să țină persoanele la distanță până la deschiderea sau închiderea completă a acesteia.

Nu împiedicați în mod voit mișcarea porții.

AVERTISMENT

În caz de funcționare necorespunzătoare, întrerupeți alimentarea și deblocați imediat motorizarea pentru a permite accesul, apoi contactați serviciul de asistență Somfy.

Nu încercați să deschideți poarta de acces manual dacă motorizarea nu a fost deblocată. Asigurați-vă că niciun obstacol natural (ramuri, pietre, iarbă înaltă etc.) nu împiedică mișcarea porții de acces.

► Instrucțiuni de siguranță privind întreținerea

⚠ PERICOL

Motorizarea trebuie să fie deconectată de la orice sursă de alimentare în timpul operațiilor de curățare și întreținere, și în timpul înlocuirii componentelor.

⚠ AVERTISMENT

În fiecare lună, asigurați-vă că:

- instalația nu prezintă semne de uzură sau de deteriorare a cablurilor și a montajului.
- motorizarea își schimbă sensul de mișcare atunci când poarta de acces întâlnește un obiect de 50 mm poziționat la jumătatea înălțimii canatului

Nu utilizați motorizarea dacă este necesară o reparație sau un reglaj. Porțile de acces în stare precară trebuie reparate, ranforsate sau schimbate. Utilizați numai piese originale pentru orice operație de întreținere sau reparație.

Orice modificare tehnică, electronică sau mecanică a motorizării va trebui efectuată cu acordul serviciului de asistență Somfy.

Dacă instalația este prevăzută cu celule fotoelectrice și/sau cu o lampă de semnalizare, curățați în mod regulat elementele optice ale celulelor fotoelectrice și lampa de semnalizare.

► Indicații privind bateriile

⚠ PERICOL

Nu lăsați bateriile/bateriile tip „pastilă”/acumulatorii la îndemâna copiilor. Păstrați-le într-un loc inaccesibil pentru aceștia. Există riscul ca acestea să fie înghițite de copii sau de animalele de casă. Pericol de moarte! În cazul în care aceste situații nu pot fi împiedicate, consultați imediat un medic sau mergeți la spital.

Aveți grijă să nu scurcircuitați bateriile, să le aruncați în foc sau să le reîncărcați. Există riscul de explozie.

► Reciclarea și eliminarea

Dacă este instalată, bateria trebuie scoasă din motorizare înainte ca aceasta să fie eliminată.

 Nu aruncați bateriile uzate ale telecomenzilor sau bateria, dacă este instalată, împreună cu deșeurile menajere. Duceți deșeurile la un punct de colectare specializat în reciclarea acestora.

 Nu aruncați motorizarea scoasă din uz împreună cu deșeurile menajere. Duceți motorizarea la distribuitor sau utilizați mijloacele de colectare selectivă puse la dispoziție de autoritățile locale.

► Reglementări

CE Somfy declară că produsul descris în aceste instrucțiuni, atunci când este utilizat în conformitate cu instrucțiunile respective, respectă cerințele esențiale ale directivelor europene aplicabile și în special ale Directivei 2006/42/CE privind mașinile și ale Directivei 2014/53/UE privind radioul.

Textul complet al declarației CE de conformitate este disponibil la următoarea adresă de internet: www.somfy.com/ce. Antoine CREZE, Responsabil pentru implementarea reglementărilor, Cluses

► Prevenirea riscurilor

Identificarea zonelor cu risc

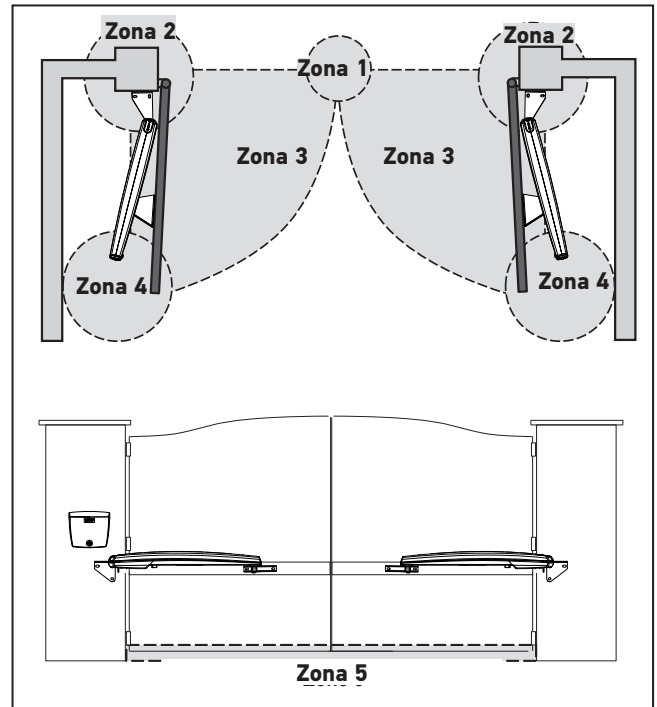

Măsurile care trebuie luate pentru prevenirea riscurilor

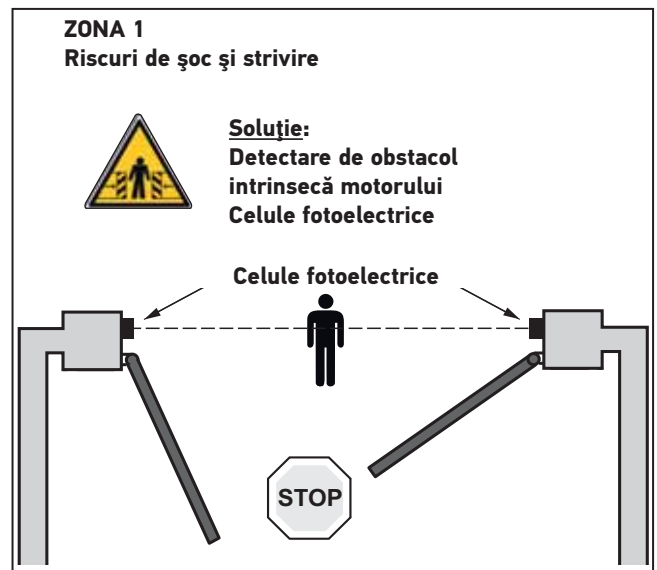

ZONA 2

Riscuri de strivire și de tăiere a mâinilor



Soluție:

Dacă pe instalație există o zonă de tăiere:

- lăsați o distanță de cel puțin 10 cm între canat și stâlp/ perete.
- efectuați o degajare în colțul stâlpului fără să-l slăbiți.

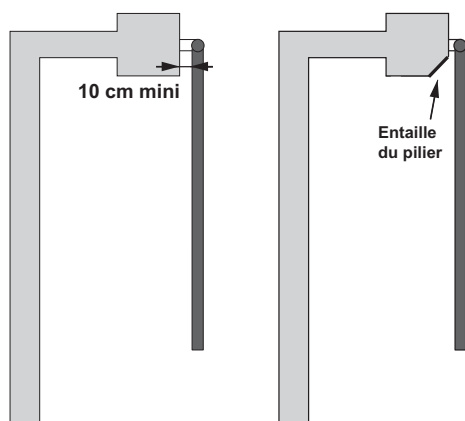

ZONA 4

Risc de prindere și strivire

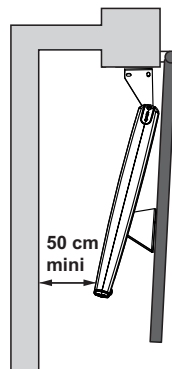

Soluție:

Detectare de obstacol intrinsecă motorului.

Dacă există o zonă de prindere între canaturi și părțile fixe din jur, lăsați o distanță de cel puțin 50 cm între canaturi și părțile fixe.

ZONA 3

Risc de șoc

Soluție:

Detectare de obstacol intrinsecă motorului.

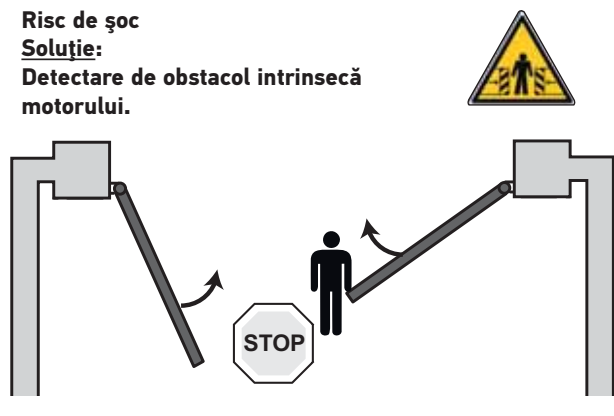

ZONA 5

Risc de antrenare a picioarelor



Soluție:

Dacă există o zonă periculoasă pentru picioare între partea inferioară a canaturilor și sol, lăsați o distanță de minim 12 cm sau maxim 5 mm între partea inferioară a canaturilor și sol.

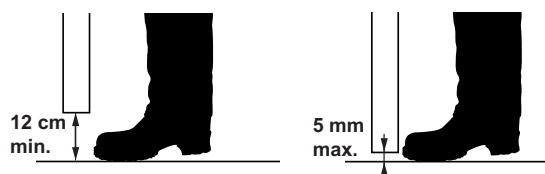

Prezentarea produsului

Conținutul pachetului

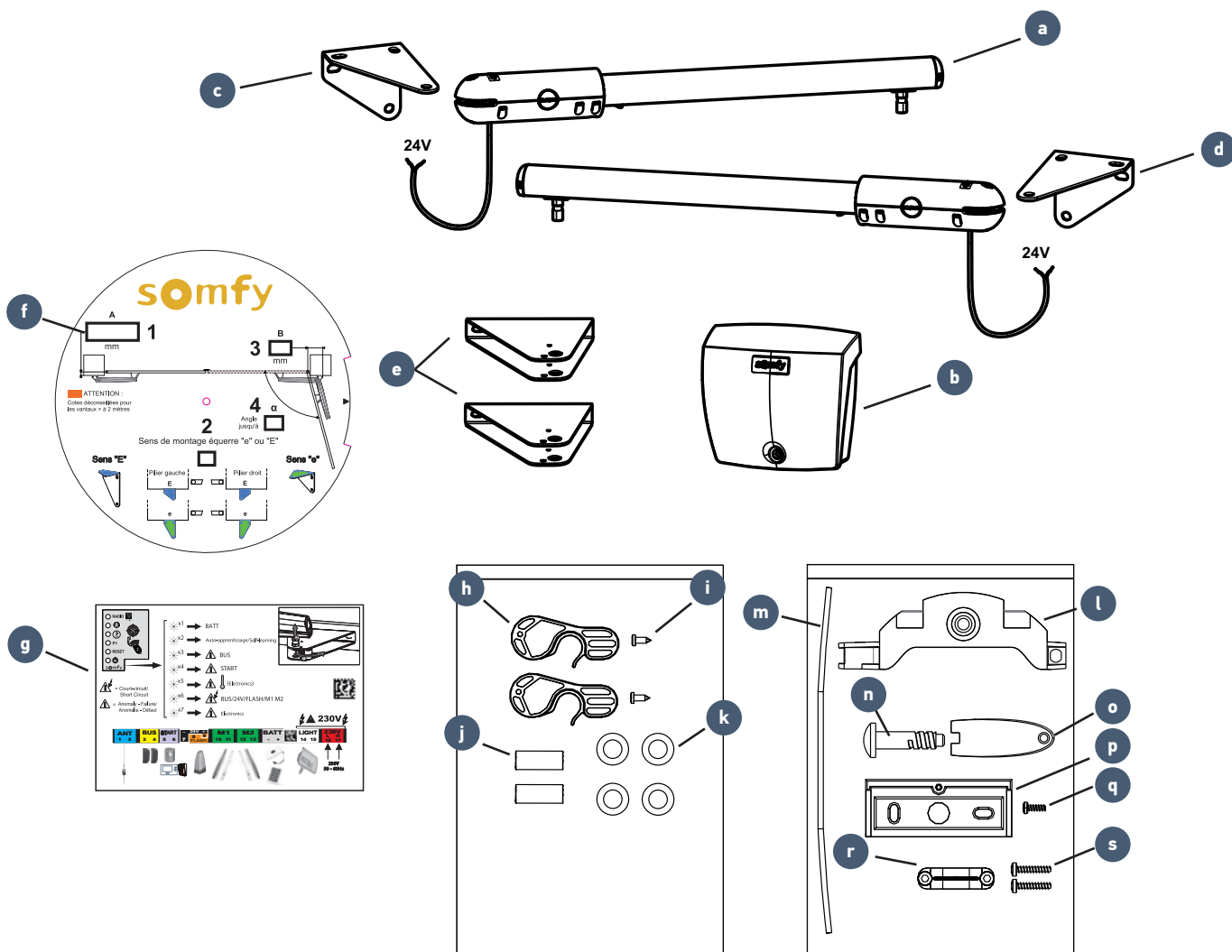

Rep.	Denumire	Cantitate
a	Cilindru 24V	x2
b	Unitate de comandă	x1
c	Suport de fixare stânga stâlp/perete	x1
d	Suport de fixare dreapta stâlp/perete	x1
e	Suport de fixare canat	x2
f	Disc pentru măsurarea cotelor	x1
g	Etichetă memorare	x1
Pungă accesorii cilindru		
h	Piesă de deblocare	x2
i	Șurub pentru piesa de deblocare	x2
j	Ax de fixare cilindru la suportul pentru stâlp/perete	x2
k	Șaibă plată M8x22	x4

Rep.	Denumire	Cantitate
Pungă de accesorii pentru unitatea de comandă		
l	Suport baterie	x1
m	Cordon de etanșeitate	x1
n	Șurub pentru capac unitate	x1
o	Cheie de deblocare capac unitate	x1
p	Colțar de fixare la perete	x1
q	Șuruburi de fixare a unității pe colțar	x1
r	Clemă de cablu	x1
s	Șurub clemă de cablu	x2

► Descrierea produsului

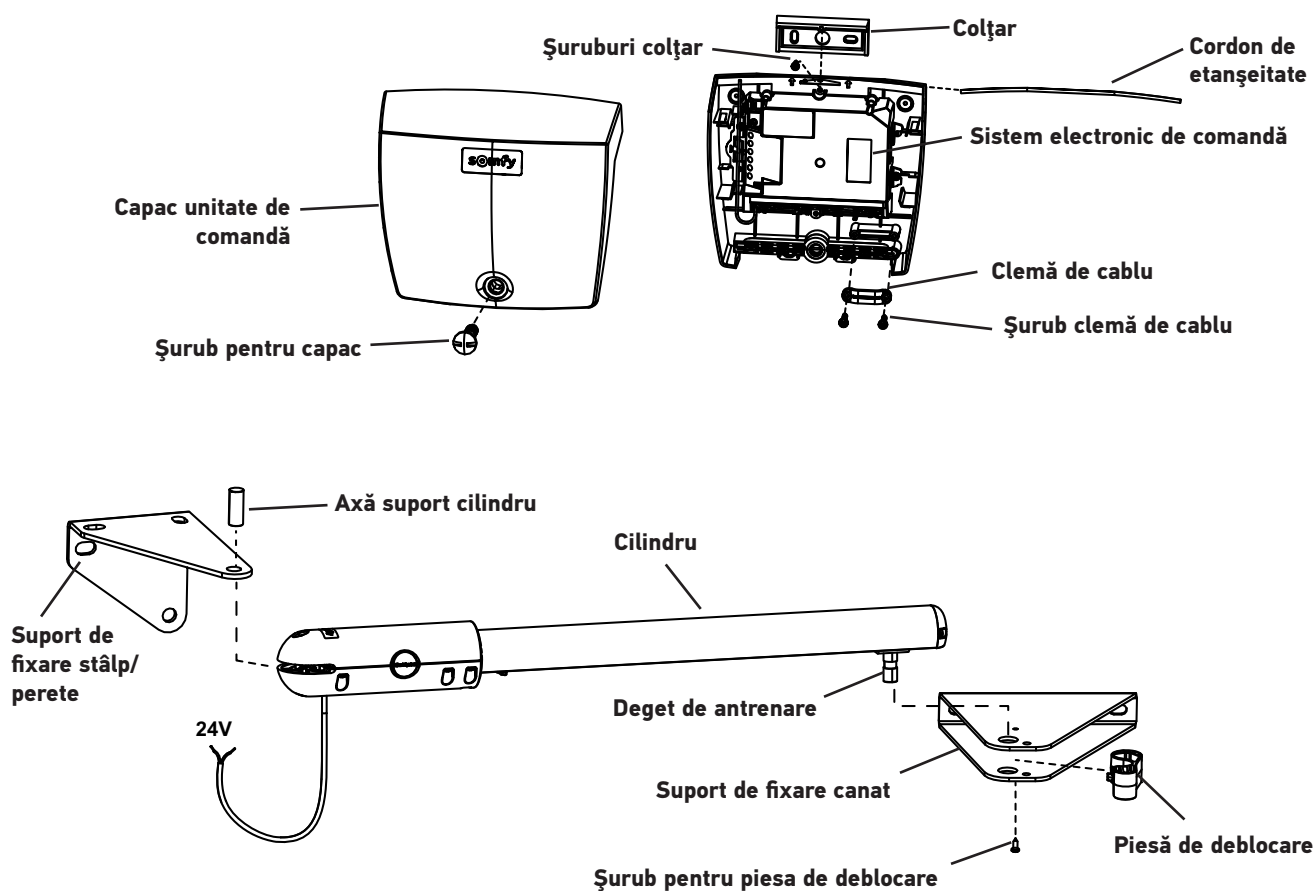

► Gabaritul

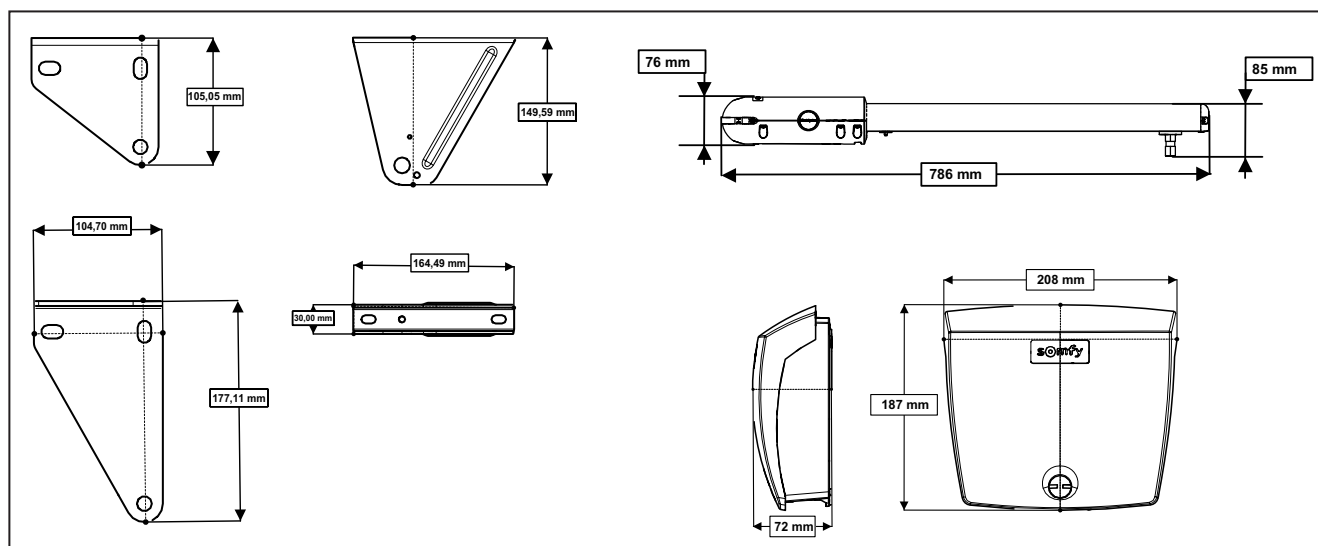

► Domeniul de aplicare

Acest automatism a fost conceput pentru a motoriza porți de acces rezidențiale cu două canaturi pentru o casă individuală.





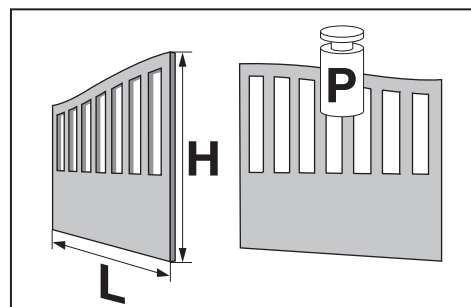

Dimensiunile și greutatea canaturilor

Greutate max. per canat (P)	200 kg
Înălțime max. per canat (H)	2 m
Lățime min./max. per canat (L)	1,25 / 2 m

Tipul de poartă de acces (plină / cu goluri) și condițiile climatice (prezența vântului puternic) pot reduce aceste valori maxime (consultați tabelul de mai jos).



Dimensiunile și greutatea canaturilor motorizabile în funcție de forța vântului

Forța vântului	Efect	Produs	SGS LINE
≥ cu 80 km/h	Nu mai merge contra vântului	 Lățime min./max. Greutate max.	1,25 / 1,5 m 200 kg
< de 80 km/h > de 40 km/h	Ramurile arborilor se unduiesc	 Lățime min./max. Greutate max.	1,25 / 2 m 200 kg
		 Lățime min./max. Greutate max.	1,25 / 1,5 m 200 kg
≤ cu 40 km/h	Nisipul se ridică	 Lățime min./max. Greutate max.	1,25 / 2 m 200 kg
		 Lățime min./max. Greutate max.	
		 Lățime min./max. Greutate max.	



Poartă de acces cu goluri



Poartă de acces pe jumătate cu goluri



Poartă de acces plină

► Vedere generală a instalației

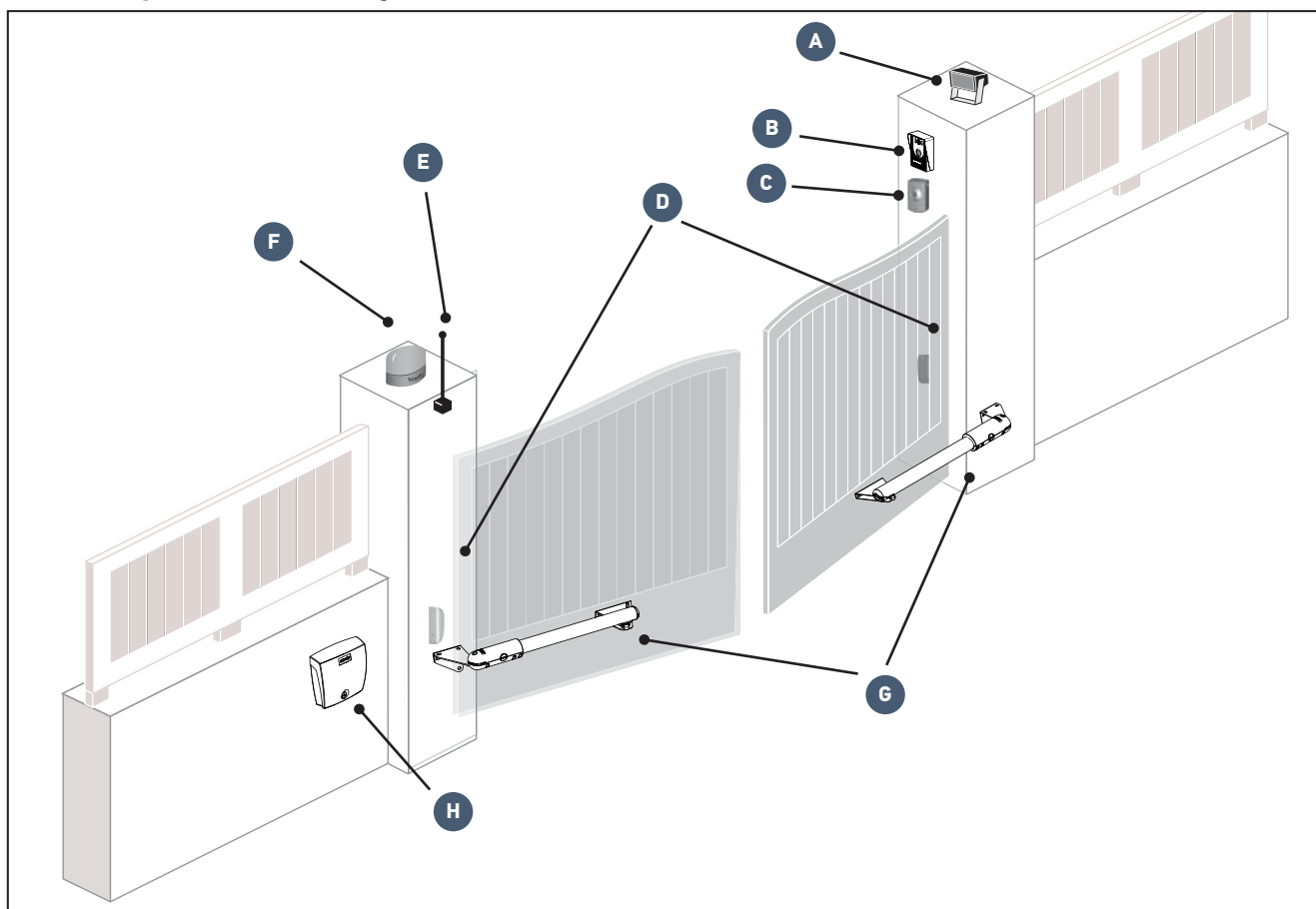

Reper	Denumire
A	Iluminare zonă*
B	Videofon*
C	Contactori cu cheie*
D	Celule fotoelectrice

Reper	Denumire
E	Antenă de comandă la distanță*
F	Lampă de semnalizare
G	Motoare
H	Unitate de comandă

*accesorii opționale

► Prezentarea sistemului electronic de comandă

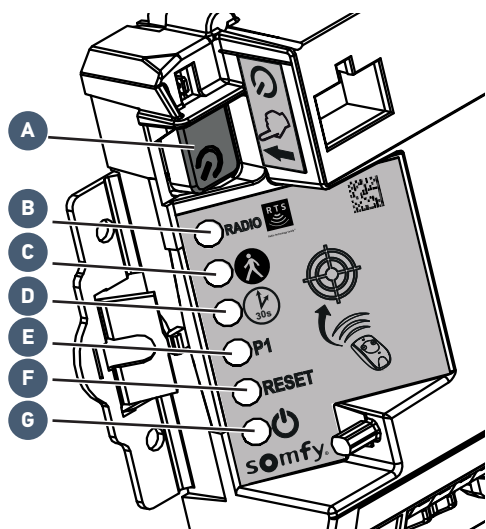

Rep.	Denumire	Funcție	
A	Buton	Activarea sistemului electronic de comandă	
B	Indicator luminos RADIO	Se aprinde de fiecare dată când sistemul electronic de comandă primește o comandă radio	
C	Indicator luminos	Se aprinde la activarea/dezactivarea deschiderii pentru pietoni	
D	Indicator luminos	Aprins	Închiderea automată a porții de acces este activată
		Stins	Închiderea automată a porții de acces nu este activată
		Aprins intermitent	este selectat parametrul „închidere automată”
E	Indicator luminos P1	Neutilizat	
F	Indicator luminos RESET	Aprins	numai reglajele sau reglajele și punctele de comandă radio sunt șterse
		Aprins intermitent	este selectată funcția de ștergere a reglajelor și a punctelor de comandă radio
G	Indicator luminos	Aprins	motorizarea funcționează corect - sistemul electronic de comandă este reactivat
		Stins	motorizarea funcționează corect - sistemul electronic de comandă este în stare de veghe
		Aprins intermitent	consultați „Diagnosticare”, pagina 31

► Cerințe prealabile pentru instalare

► Aspecte de verificat înainte de instalare

Poarta de acces

Poarta de acces este în stare bună: se deschide și se închide în mod normal, fără a fi forțată. Aceasta rămâne orizontală pe durata întregii curse. Se deschide spre interiorul proprietății.

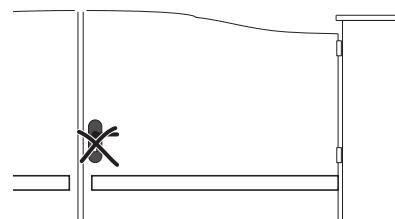
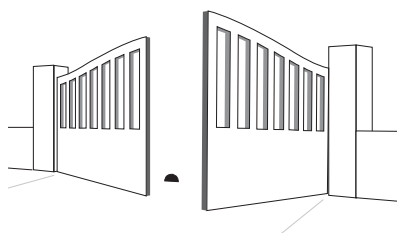
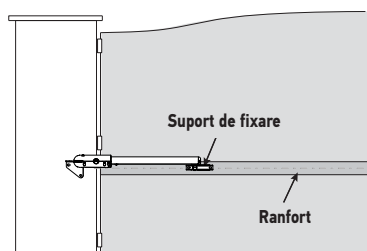

Ranforturile

Motoarele trebuie să fie fixate pe ranforturile orizontale ale canatelor, plasate ideal la 1/3 din înălțimea porții de acces.

În absența ranforturilor, prevedeați contraplăci din metal de aproximativ 4 mm grosime.

Stâlpii

Stâlpii trebuie să aibă o structură robustă și o lățime de cel puțin 21 de cm. În caz contrar, este posibil să fie necesare amenajări pe stâlp pentru a asigura o bună implantare și o bună rezistență a colțarului.

Nu este recomandată fixarea echerului la rasul stâlpului: risc de fisurare.

Opritoare de închidere pe sol

Cursa porții de acces la închidere trebuie să fie delimitată cu opritoarele fixate solid pe sol.

Opritoarele de deschidere sunt integrate în motor (consultați „Reglarea opritorului de deschidere”, pagina 19).

Încuietorie mecanică

Dacă poarta de acces este echipată cu o încuietorie mecanică, aceasta trebuie să fie scoasă.

► Preechipare electrică

Caburi de prevăzut

- Alimentare de la rețeaua electrică: cablu 3 x 1,5 mm² sau 3 x 2,5 mm² pentru o utilizare în exterior (tip H07RN-F mini).
- Legătură între motoare: cablu 2 x 1 mm²; prevedeți o cutie de derivație IP 55 pentru a proteja legătura dintre cablul care iese din motor și extensia care se duce la unitatea de comandă.
- Legarea celulelor: cablu 2 x 0,75 mm².



Trecerea cablului de alimentare trebuie să fie prevăzută în conformitate cu normele electrice în vigoare în țara de utilizare.

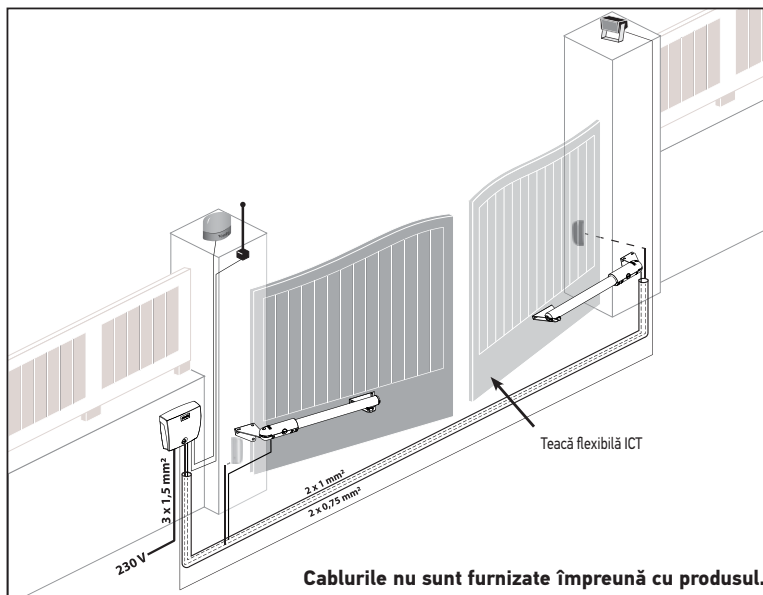
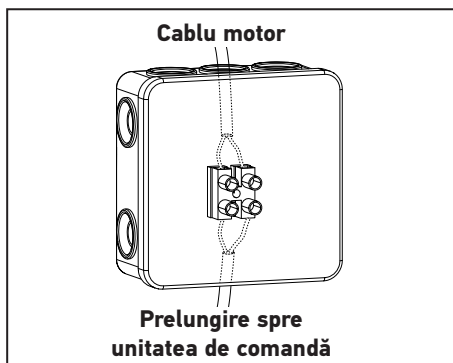

Trecerea cablurilor

- Cablurile îngropate trebuie echipate cu o teacă de protecție cu un diametru suficient pentru trecerea tuturor cablurilor.
- Amenajați o alimentare electrică de 230 V cât mai aproape de amplasarea unității de comandă.

► Cabluri de prevăzut



Dacă realizarea unui șanț nu este posibilă, utilizați un canal de trecere a cablurilor care va putea să susțină trecerea vehiculelor (ref. 2400484).



Detaliile cablajului sunt furnizate în secțiunea „Cablare accesoriilor” de la pagina 22.

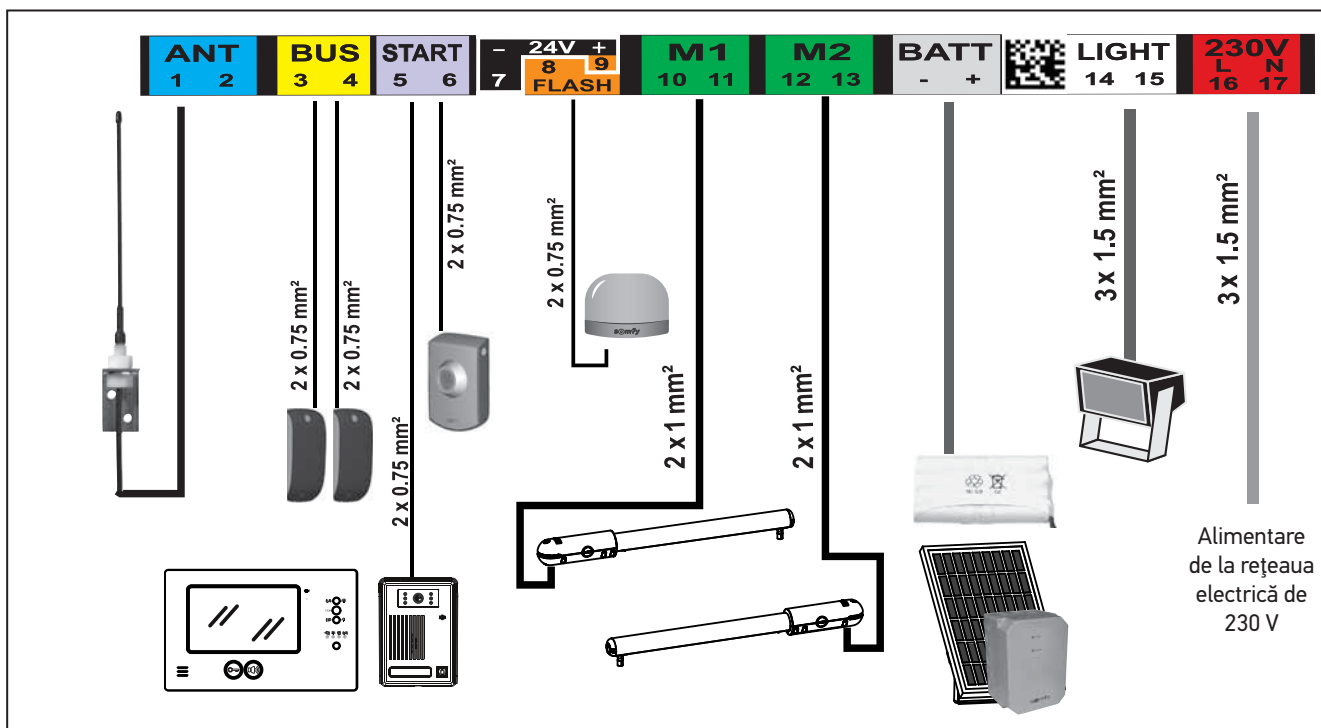

► Scule necesare la instalare (nefurnizate)

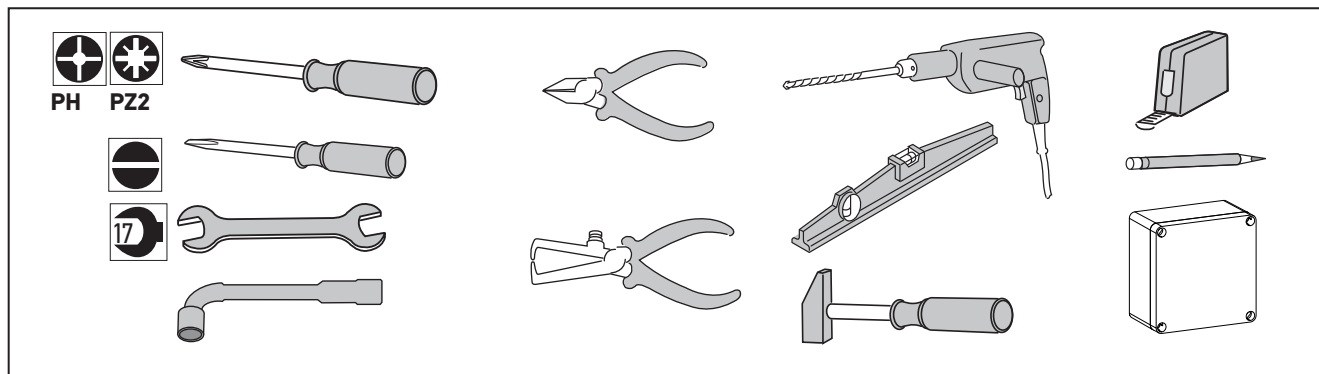

► Piese de fixare necesare la instalare (nefurnizate)

Aceste informații sunt furnizate cu titlu orientativ.

Pentru a fixa ...	Cantitate	
SUPPORTURI PE STÂLPURI/PEREȚI		
	Piese de fixare adaptate la materialul stâlpului/peretelui (șuruburi, prezoane, ancore chimice, ...): - diametru: de la 8 la 10 mm - cap hexagonal	6
	Șaibe: - diametru interior: de la 8 la 10 mm - diametru exterior: de la 16 la 20 mm Piulițe: - diametru: 17 mm	6
SUPPORTURI PE CANATURI		
	Piese de fixare adaptate la materialul ranfortului canaturilor: - diametru: 8 mm - lungime adaptată la grosimea ranfortului canaturilor	6
	Șaibe furnizate - diametru interior: 8 mm - diametru exterior: 22 mm	6
UNITATE DE COMANDĂ		
	Piese de fixare adaptate la materialul stâlpului/peretelui - șurub cu diametrul de: 3,5 - 4,5 mm - cap frezat sau bombat - dibluri tip „S” pentru beton: S5, S6 sau S8	4

1.1 Măsurarea cotelor

Măsurați cotele utilizând discul (f) pentru a determina poziția motoarelor pe stâlpi.

Notă: Pentru aceste măsurări, canaturile și balamalele lor sunt considerate ca fiind pe aceeași axă.

Atenționare: Lăsați o distanță de minim 50 cm între canaturi și părțile fixe (consultați „Prevenirea riscurilor”, pagina 4).

1 Măsurați cota A.

Raportați cota A măsurată pe disc.

ATENȚIE
Cote nerecomandate pentru canaturile > de 2 metri

3 Determinați cota B

ATTENTION :
Cotes déconseillées pour les vantaux > à 2 mètres

Angle jusqu'à α

Sens de montage équerre "e" ou "E"

Sens "E" Pilier gauche E Piler droit E Sens "e"

2 Este indicat sensul de montare (e sau E) a suportului de fixare a cilindrului pe stâlp.

Sens "E" Stâlp stânga E Stâlp dreapta E Sens "e"

ATENȚIE la sensul de fixare în sus și în jos a suportului.

Sens corect Sens incorect

4 Unghiul de deschidere α maxim este indicat.

Unghi până la α

! Respectați unghiul maxim de deschidere dat de disc.



Recomandare: cota A este negativă

În cazul în care cota A este negativă, balamaua canatului este în fața stâlpului. Vă recomandăm să adăugați o cală astfel încât suportul de fixare a cilindrului să fie pe axa balamalei canatului și cota A să fie egală cu 0 cm.

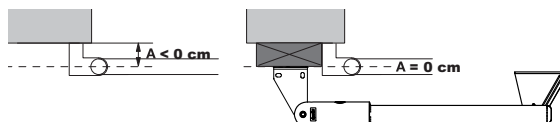

1.2 Fixarea suporturilor pe stâlp

► Trasarea axelor AM și AH

1. Raportați cota B pe stâlp plecând din axa balamalei și trasați o axă verticală AM pe stâlp.
2. Trasați axa orizontală AH pe stâlp, până la jumătatea înălțimii ranfortului.

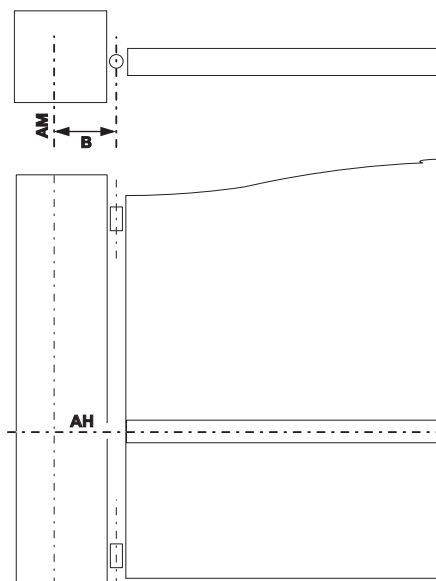

Autocontrol înainte de etapa următoare
Ați trasat corect axele AM și AH?

► Găurirea stâlpilor

1

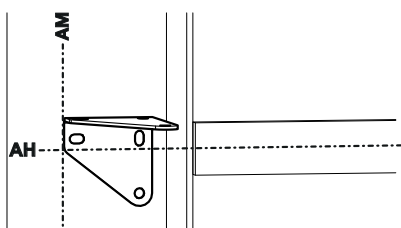

Aliniați reperele trasate pe suport pe axa AH și aliniați marginea suportului în raport cu axa AM.
Notă: Reperele trasate pe suport se găsesc sub găurile alungite.



Poziționați suportul în sensul e sau E definit la etapa 2 a măsurării cotelor (consultați pagina 12).

Stâlp stânga

Sens E

Sens e

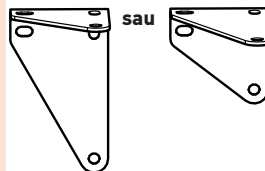

Stâlp dreapta

Sens e

Sens E

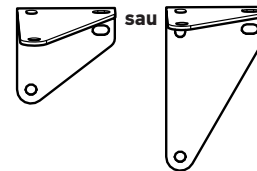

Atenție la sensul de fixare în sus și în jos a suportului.



Sens corect



Sens incorect

2

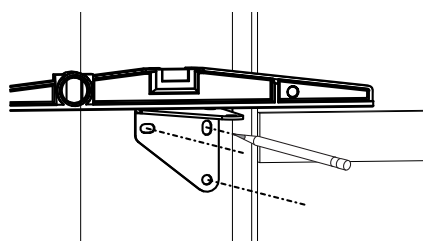

Verificați orizontalitatea suportului, apoi marcați găurile de fixare a suportului.

3

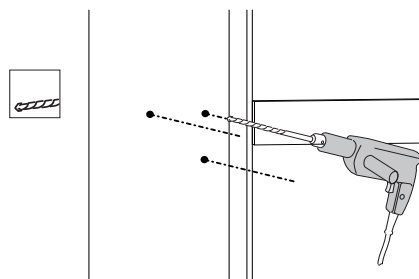

Executați 3 găuri pe fiecare stâlp în pozițiile reperate (consultați pagina 11 pentru diametrul de găurire corespunzător unui șurub adaptat).

► Prinderea suportului de fixare pe stâlp

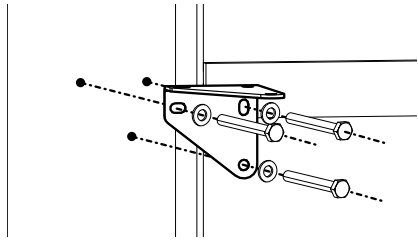
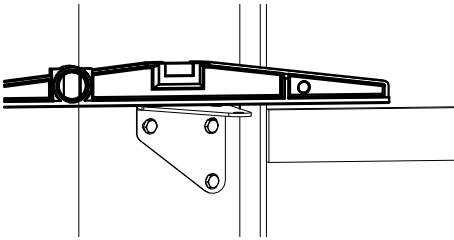
<p>1</p>  <p>Prindeți suportul de fixare pe stâlp cu șuruburi adaptate suportului de fixare.</p>	<p>2</p>  <p>Verificați nivelul suportului. Strângeți din nou dacă este necesar.</p>
--	---



Autocontrol înainte de etapa următoare
Ați verificat orizontalitatea perfectă a suporturilor pe stâlpi?

► Montarea cilindrului pe suportul de fixare

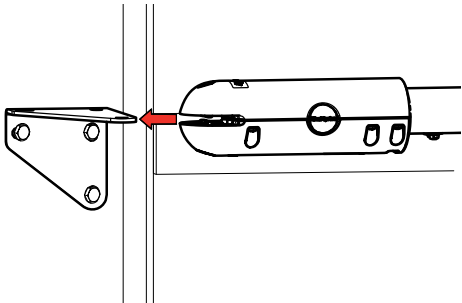
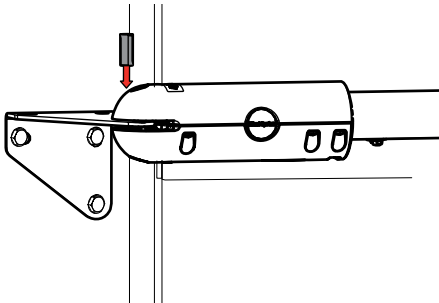
<p>1</p>  <p>Montați cilindrul pe suportul de fixare.</p>	<p>2</p>  <p>Blocați-l cu axul (j).</p>
--	---

1.3 Fixarea motoarelor pe canaturi

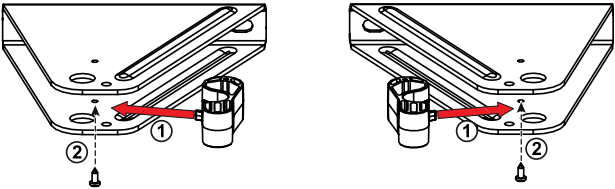
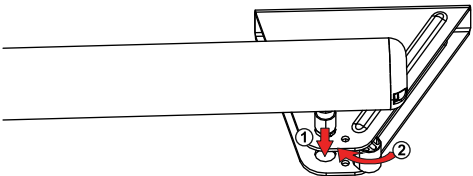
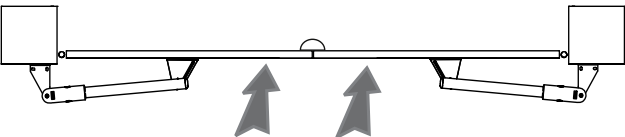

Nu acționați niciodată cilindrul înainte de a fi terminat fixarea acestuia pe canat. Reglarea opritorului intern al cilindrului ar putea fi afectată și ar putea rezulta defecțiuni.

<p>1</p> 	<p>Fixați piesa de deblocare (h) pe suportul de fixare a canatului (e) cu ajutorul șurubului (i).</p>
<p>2</p> 	<p>Montați cilindrul pe suportul de fixare a canatului. Prindeți piesa de deblocare pe degetul de antrenare al cilindrului pentru a-l bloca.</p>
<p>3</p> 	<p>Închideți poarta de acces.</p> <div style="border: 1px solid red; padding: 5px; margin-top: 10px;"> <p>! În poziție închisă, canaturile trebuie să fie bine amplasate pe opritorul de pe sol și cilindrul pe opritorul său intern.</p> </div>

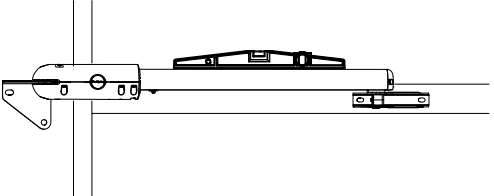
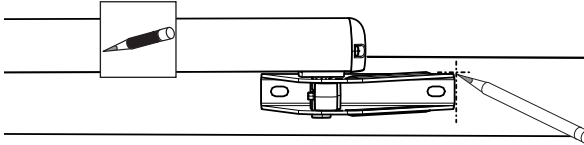
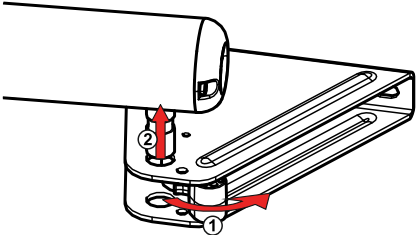
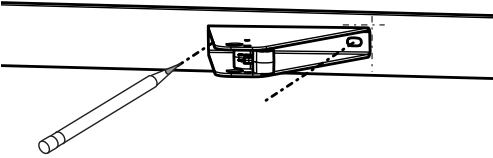
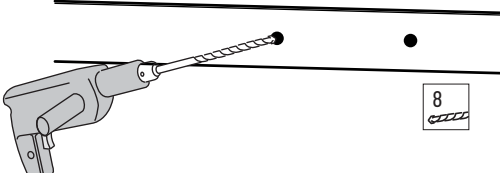
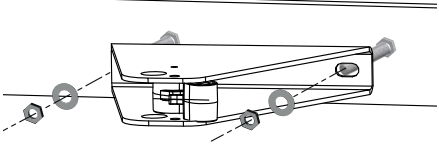
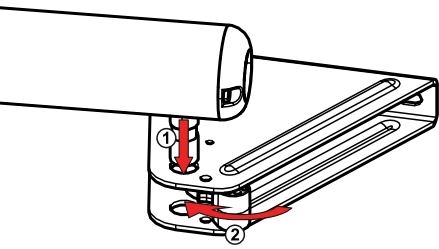
<p>4</p> 	<p>Puneți suportul de fixare a canalului pe ranfortul canalurilor. Verificați orizontalitatea cilindului.</p>
<p>5</p> 	<p>Marcați reperele pe laturile suportului de fixare a canalului.</p>
<p>6</p> 	<p>Desprindeți piesa de deblocare, apoi scoateți cilindrul din suportul de fixare a canalului.</p>
<p>7</p> 	<p>Repoziționați suportul de fixare a canalului, apoi marcați găurile de fixare în centrul găurilor alungite.</p>
<p>8</p> 	<p>Găuriți canalurile cu diametrul de 8.</p>
<p>9</p> 	<p>Fixați suportul de fixare a canalului în cele două puncte pe canaluri, utilizând șuruburile adaptate la materialul ranfortului și șaibele (k) furnizate.</p> <div style="border: 1px solid red; padding: 5px; margin-top: 10px;"> <p>! Șaibele (k) furnizate trebuie să fie montate în mod obligatoriu.</p> </div>
<p>10</p> 	<p>Instalați cilindrul. Prindeți piesa de deblocare pe degetul de antrenare pentru a-l bloca.</p>

Autocontrol înainte de etapa următoare
Ați verificat dacă cilindrii sunt perfect orizontali?

1.4 Instalarea unității de comandă

► Poziția unității de comandă

Unitatea va fi montată pe un stâlp/perete lângă partea de alimentare electrică.

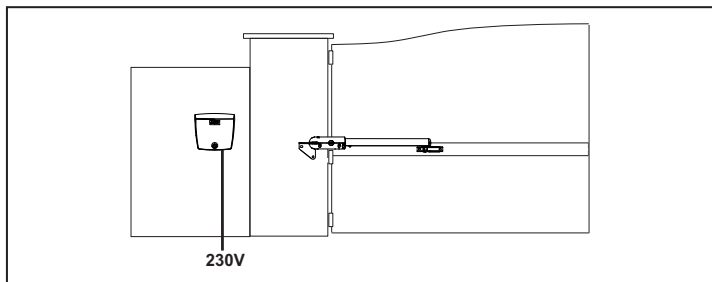

► Instalarea cordonului de etanșeitate

Îmbinați cordonul de etanșeitate (m) în partea superioară a unității de comandă.

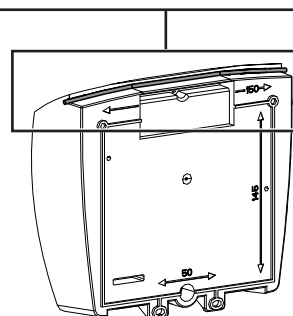
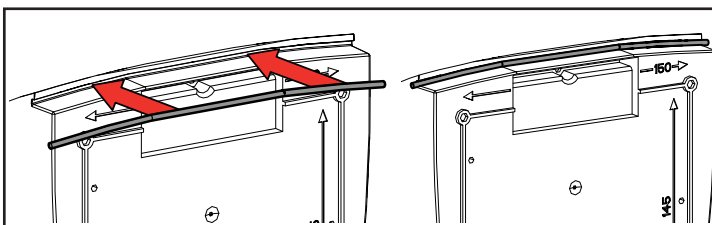

► Verificarea poziției antenei

Poziționarea corespunzătoare a antenei este esențială pentru o funcționare optimă.



Nu tăiați niciodată firul de antenă.

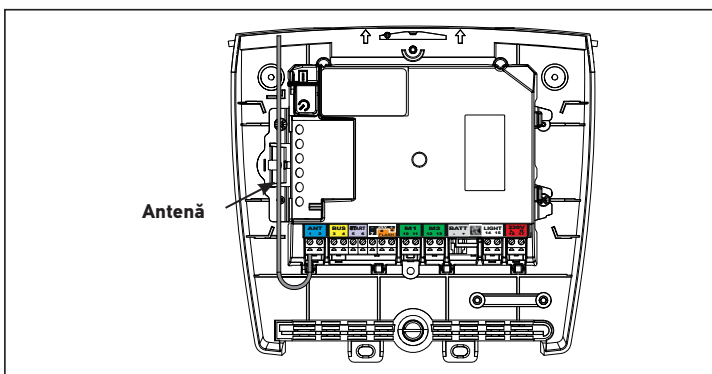

► Fixarea unității de comandă

<p>1</p>	<ul style="list-style-type: none"> • Puneți colțarul de fixare a unității (p) pe stâlp/perete. • Verificați orizontalitatea acestuia prin amplasarea unei nivele în locul prevăzut. • Marcați punctele de fixare ale colțarului.
<p>2</p>	<p>Scoateți colțarul și găuriți stâlpul/peretele. Diametrul de găurire trebuie să fie definit în funcție de tipul de șuruburi utilizate pentru fixare (consultați pagina 11).</p>

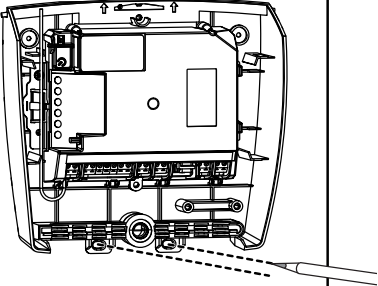
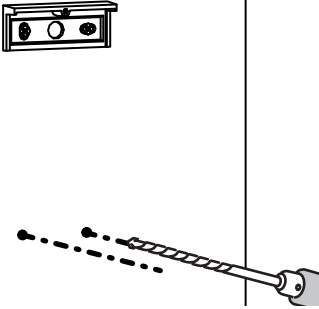
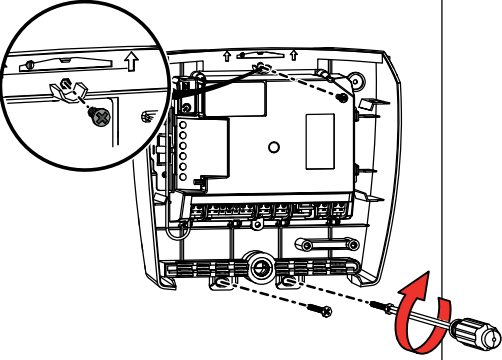
<p>3</p>		<p>Fixați colțarul pe stâlp/perete.</p>
<p>4</p>		<p>Amplasați partea inferioară a unității pentru a marca cele 2 puncte de fixare din partea inferioară a unității.</p>
<p>5</p>		<p>Scoateți partea inferioară a unității, apoi găuriți stâlpul/peretele. Diametrul de găurire trebuie să fie definit în funcție de tipul de șuruburi utilizate pentru fixare (consultați pagina 11).</p>
<p>6</p>		<p>Fixați partea inferioară a unității pe stâlp/perete: 1 șurub (q) pentru a fixa unitatea pe colțar + 2 șuruburi pentru a fixa unitatea pe stâlp/perete.</p>

1.5 Racordarea motoarelor



Motorul M1 acționează canatul care:

- se deschide primul și se închide ultimul,
- se deschide în modul deschidere pentru pietoni al porții de acces.

1

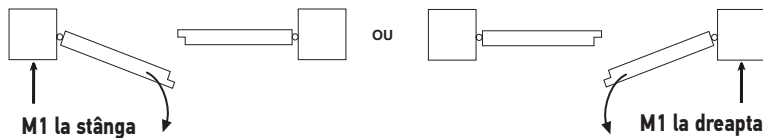

Cu poarta de acces închisă, identificați canatul care trebuie să se deschidă primul. Motorul M1 acționează acest canat.

2 Conectați motoarele așa cum este indicat în tabelul de mai jos:

Branșați firul motorului ...	pe borna ...	
M1	albastru	10
	maro	11
M2	albastru	12
	maro	13

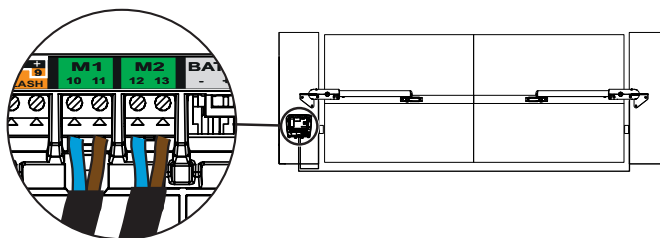

1.6 Racordarea la alimentarea de la rețeaua electrică



Pentru siguranța dumneavoastră, aceste operații trebuie realizate fără tensiune.

Utilizați un cablu de 3 x 1,5 mm² pentru o utilizare în exterior (cel puțin de tip H07RN-F).

Utilizați în mod obligatoriu clema de cablu furnizată. Pentru orice tip de cablu de joasă tensiune utilizat, asigurați-vă că acesta rezistă la o forță de tracțiune de 100 N.

Verificați să nu se fi mișcat conductorii după ce ați aplicat această forță de tracțiune.

1

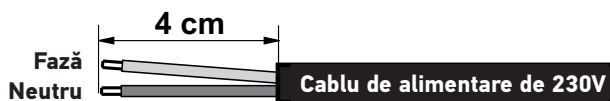

Pe un cablu de tip 3 x 1,5 mm², pregătiți 2 fire de 4 cm (fază și neutru).

2

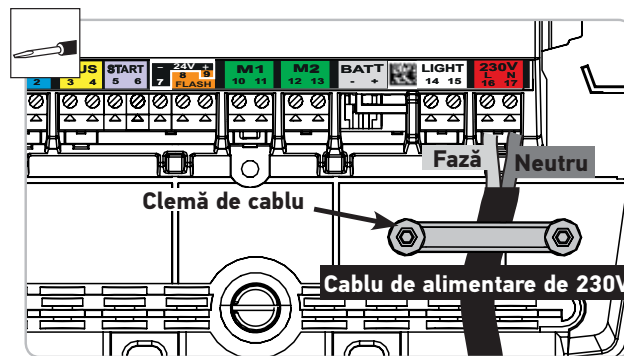

- Racordați faza și neutrul la bornele 16 și 17 (etichetă roșie „230 V”).
- Blocați cablul de alimentare de 230 V cu clema de cablu furnizată (r).
- Puneți o regletă de borne pe firul de împământare (galben/verde) și introduceți în unitatea de comandă.

2.1 Punerea sub tensiune a instalației

Indicatorul luminos  clipește (2 ori).

Motorizarea este sub tensiune și în așteptarea autoînvățării.

Dacă indicatorul luminos  nu se aprinde sau numărul de clipiți nu este cel așteptat: consultați „Diagnosticare”, pagina 31.

2.2 Reglarea opritorului de deschidere





Opritoare de deschidere

Opritoarele de deschidere sunt integrate în cilindru. Acestea delimitează cursa porții de acces la deschidere.

Atenționare: Instalația trebuie să fie echipată cu opritoare de închidere fixate la sol pentru a delimita cursa porții de acces la închidere.

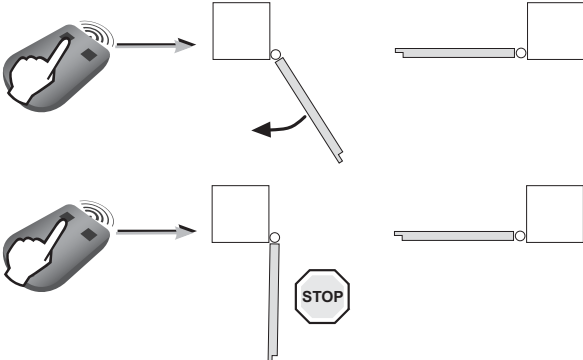
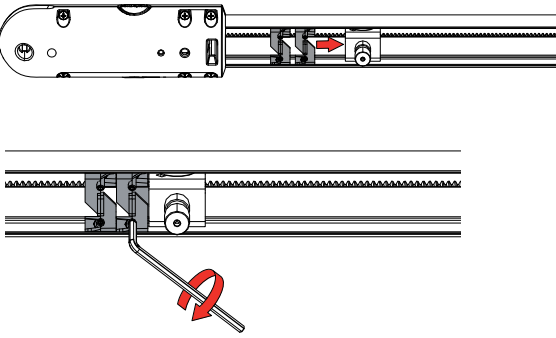
În această fază, o apăsare pe tasta 1 a telecomenzii programate nu va antrena decât deschiderea și oprirea porții de acces (prima apăsare = deschidere, a 2-a apăsare = oprire, a 3-a apăsare = deschidere, a 4-a apăsare = oprire etc.); poziția de deschidere dorită poate fi astfel setată de mai multe ori. Închiderea porții de acces va fi posibilă după instalarea opritoarelor de deschidere.

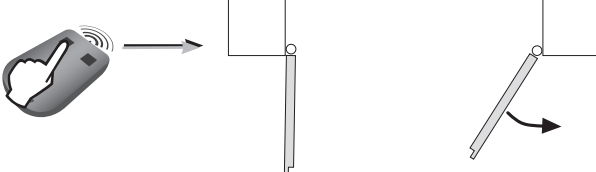
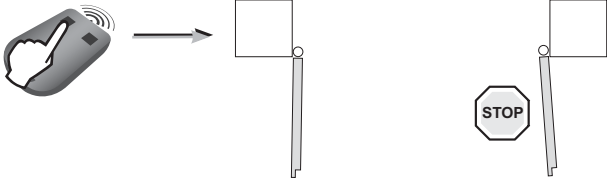
<p>1</p> 	<ul style="list-style-type: none"> • Apăsați pe tasta 1 a telecomenzii. După câteva secunde, se deschide primul canat, cu viteză mică. În cazul în care canatul nu se deschide, verificați dacă motoarele sunt cablate așa cum este indicat la pagina 18. • Apăsați din nou pe tasta 1 a telecomenzii pentru a opri canatul în poziția de deschidere dorită.
<p>2</p> 	<p>Poziționați opritoarele de deschidere în contact cu nuca cilindricului, apoi strângeți opritoarele cu un imbus cu diametrul de 3 (2 șuruburi pe opritor).</p> <div style="border: 1px solid red; padding: 5px; display: inline-block;">  <p>Rotiți cheia de 2 ori după realizarea contactului.</p> </div>
<p>3</p> 	<p>Apăsați pe tasta 1 a telecomenzii. Se deschide cel de-al doilea canat.</p>
<p>4</p> 	<p>Apăsați din nou pe tasta 1 a telecomenzii pentru a opri canatul în poziția de deschidere dorită.</p>

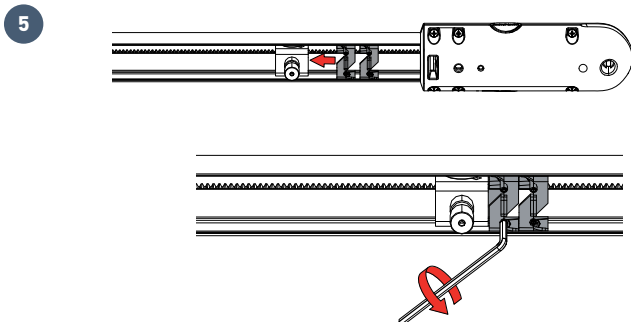

Poziționați opritoarele de deschidere în contact cu nuca cilindricului, apoi strângeți opritoarele cu un imbus cu diametrul de 3 (2 șuruburi pe opritor).



Rotiți cheia de 2 ori după realizarea contactului.

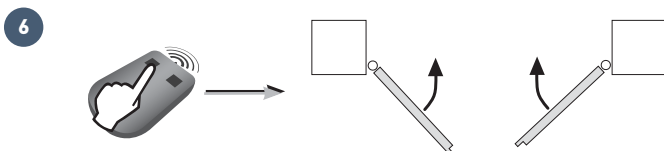

Apăsați pe tasta 1 a telecomenzii pentru a închide complet poarta de acces. Canaturile se închid unul după celălalt.



Autocontrol înainte de etapa următoare
Ați reglat poziția opritorului de deschidere pe fiecare motor?

2.3 Autoînvățarea cursei porții de acces

Asigurați-vă că instalația este sub tensiune: indicatorul luminos  clipește (2 ori).

Cazul 1: Prima punere în funcțiune a motorizării dumneavoastră

Apăsați pe tasta 1 a telecomenzii pentru a lansa o mișcare COMPLETĂ de deschidere a porții de acces.

Atunci când poarta de acces este complet deschisă, apăsați din nou pe tasta 1 a telecomenzii pentru a lansa o mișcare COMPLETĂ de închidere a porții de acces.

Atunci când poarta de acces este complet închisă, indicatorul luminos  al unității de comandă SE APRINDE CONTINUU.

Cazul 2: Tocmai ați șters reglajele

Lansați 4 mișcări complete de deschidere și de închidere a porții de acces.

La sfârșitul celor 4 mișcări, indicatorul luminos  al unității de comandă trebuie să SE APRINDĂ CONTINUU.

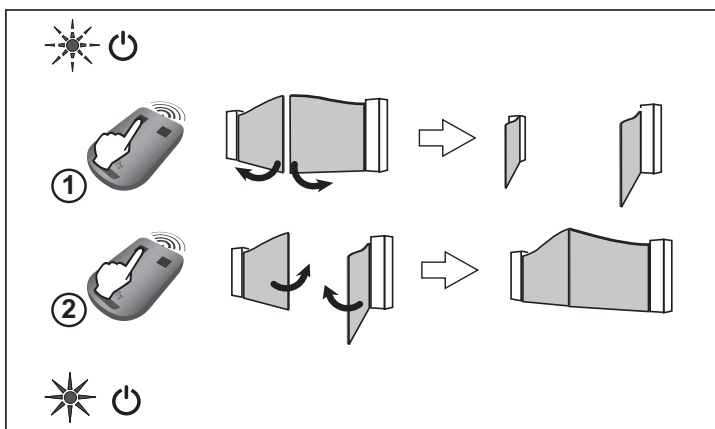

Mișcările porții de acces nu trebuie să fie întrerupte (deschidere/închidere completă). În caz contrar, învățarea va fi reluată automat la următoarea deschidere comandată.

Dacă indicatorul luminos  clipește, reluați autoînvățarea cursei canaturilor (4 mișcări complete de deschidere și închidere).

Dacă indicatorul luminos  continuă să clipească, consultați „Diagnosticare”, pagina 31.

Dacă poarta de acces se re deschide la sfârșitul mișcării de închidere, slăbiți și decalați ușor suporturile canaturilor spre centrul porții de acces.



AVERTISMENT

La sfârșitul instalării, verificați obligatoriu dacă detectarea de obstacole este în conformitate cu anexa A la norma EN 12 453.

2.4 Închiderea unității de comandă

1

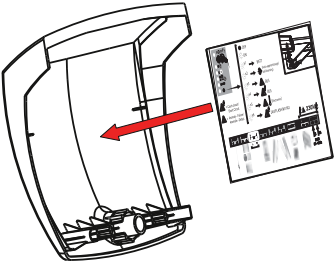

Lipiți eticheta memo (g) în partea inferioară a capacului unității de comandă.

2

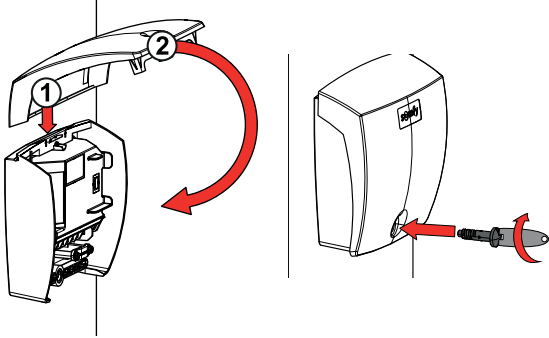

Închideți unitatea de comandă și prindeți cu șuruburi capacul.

2.5 Punerea în stare de veghe/Activarea sistemului electronic de comandă

i Când a fost efectuată autoînvățarea, sistemul electronic trece automat în stare de veghe după 5 minute de inactivitate, pentru a face economii de energie. În stare de veghe, toți indicatorii luminoși sunt stinși.

Pentru a verifica dacă motorizarea este sub tensiune sau pentru a verifica/modifica parametrizarea, apăsați 2 secunde pe butonul  pentru a activa sistemul electronic. Sistemul electronic va reveni automat în stare de veghe după 5 minute de inactivitate.

2.6 Deschiderea totală și închiderea porții de acces

i Telecomenzile livrate în kit sunt deja memorate și programate astfel încât tasta 1 a telecomenzilor să comande deschiderea totală a porții de acces.



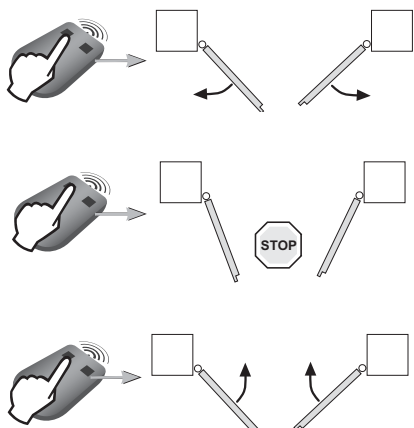

- Poartă de acces închisă: apăsați pe tasta 1 a telecomenzii pentru a deschide complet poarta de acces.
- Poartă de acces în mișcare: apăsați pe tasta 1 a telecomenzii pentru a opri poarta de acces.
- Poartă de acces deschisă: apăsați pe tasta 1 a telecomenzii pentru a închide poarta de acces.

2.7 Detectarea obstacolelor

Dacă este detectat un obstacol (efort anormal asupra motorizării):

- În timpul deschiderii porții de acces: poarta de acces se oprește.
- În timpul închiderii porții de acces: poarta de acces se oprește și se redeschide.

2.8 Instruirea utilizatorilor

Instruiți toți utilizatorii cu privire la utilizarea în condiții de maximă siguranță a acestei porți de acces motorizate (utilizare standard și principiu de deblocare) și la verificările periodice obligatorii.



Pentru siguranța dumneavoastră, aceste operații trebuie realizate fără tensiune.



Este recomandat să realizați autoînvățarea cursei porții de acces înainte de a racorda accesoriile (celule fotoelectrice, lampă de semnalizare etc.).

3.1 Celule fotoelectrice



Cablarea unui al doilea set de celule fotoelectrice nu este posibilă pe această motorizare.

► Instalarea

După cablarea celulelor fotoelectrice:

- repuneți motorul sub tensiune,
- lansați o mișcare de deschidere sau de închidere a porții de acces.

Celulele fotoelectrice sunt recunoscute de sistemul electronic de comandă la sfârșitul acestei mișcări.

► Funcționarea cu celule fotoelectrice

Dacă celulele sunt acoperite în timpul închiderii porții de acces, poarta de acces se oprește și se re deschide.

► În caz de eliminare a celulelor fotoelectrice

După eliminarea celulelor fotoelectrice, repuneți motorul sub tensiune, apoi efectuați procedura „Dezactivarea închiderii automate” de la pagina 26.

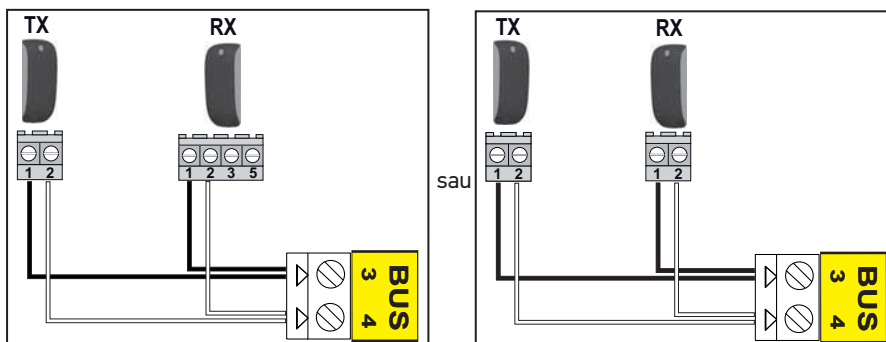

3.2 Lampă de semnalizare



Bec 10 W - 24 V MAXIM - Utilizarea becului cu o putere mai mare de 10 W - 24 V poate determina funcționarea necorespunzătoare a motorizării.

► Funcționarea lămpii de semnalizare

Lampa clipește în timpul mișcării porții de acces.

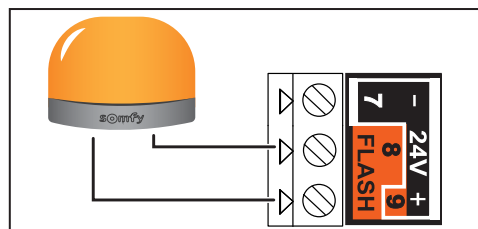

3.3 Baterie (opțional)



Acest accesoriu este incompatibil cu o alimentare solară.



Pentru a mări autonomia bateriei în funcționare, comenzile cu fir sunt dezactivate; numai telecomenzile și punctele de comandă radio permit comandarea porții de acces.

Bateria de rezervă asigură funcționarea porții de acces în caz de defecțiune electrică.

Indicatorul luminos clipește (1 clipire) atunci când motorul funcționează pe baterie.

► Caracteristici tehnice ale bateriei

- Autonomie: 10 cicluri în continuu sau 24 de ore pe o poartă în stare perfectă.
- Timp de încărcare înainte de utilizarea optimă a bateriei: 48 de ore.
- Durată de viață: 3 ani.

Pentru o durată de viață optimă a bateriei, întrerupeți alimentarea electrică a porții de acces cel puțin de 3 ori pe an, pentru ca aceasta să funcționeze câteva cicluri pe baterie.

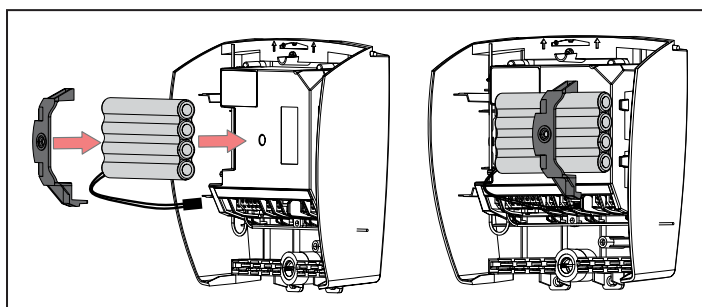

3.4 Antenă de comandă la distanță (opțional)



O antenă de comandă la distanță cu rază de acțiune mare poate înlocui antena cu fir.

Aceasta se amplasează pe partea superioară a stâlpului și trebuie să fie liberă.

Este racordată la bornele 1 și 2 (etichetă albastră „ANT”) ale unității de comandă:

- miezul firului la borna 1,
- tresa de masă la borna 2.

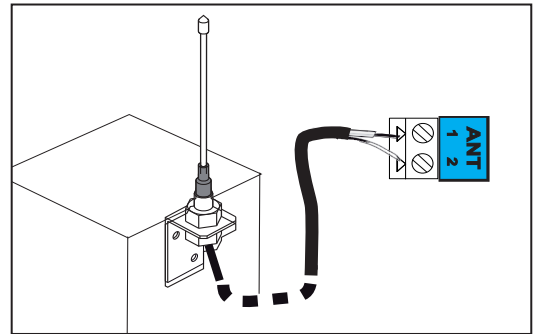

3.5 Videofon (opțional)



Acest accesoriu este incompatibil cu o alimentare solară.
Nu racordați decât un contact fără potențial nealimentat.

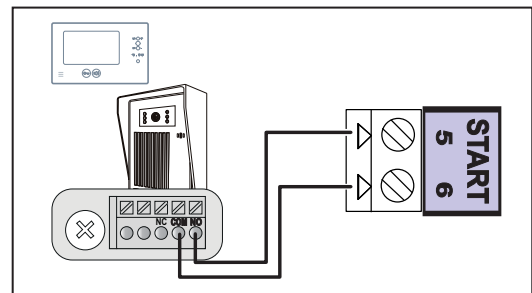

3.6 Contactor cu cheie (opțional)



Acest accesoriu este incompatibil cu o alimentare solară.

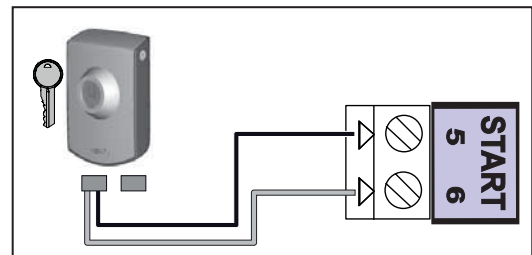

3.7 Iluminarea zonei (opțional)



Acest accesoriu este incompatibil cu o alimentare solară.
Utilizați numai becuri cu halogen sau becuri cu incandescență de maxim 500 W pentru iluminarea zonei.

► Funcționarea iluminării zonei

Sistemul de iluminare a zonei se aprinde la fiecare pornire a motorizării. Se oprește automat la 1 minut și 30 de secunde după terminarea mișcării.

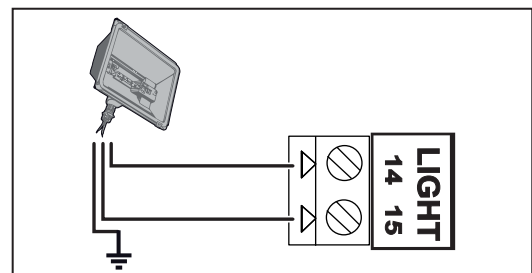

3.8 Alimentare solară (opțional)



Nu bransați niciodată motorul la o alimentare de 230 V în timp ce este bransat la o alimentare solară, deoarece unitatea electronică a motorului riscă să fie deteriorată.

Atunci când motorul funcționează cu alimentare solară:

- numai telecomenzile și punctele de comandă radio permit comandarea porții de acces (comenzile cu fir sunt dezactivate),
- accesoriile de siguranță cu fir rămân activate (celule fotoelectrice, lampă de semnalizare).

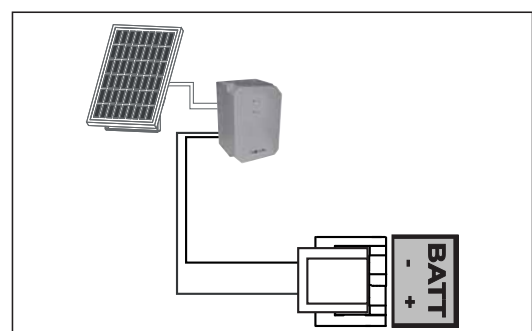

4.1 Deschidere pentru pietoni

► Funcționarea deschiderii pentru pietoni

<p>Deschidere pentru pietoni (motor M1) printr-o apăsare pe tasta activată.</p>	
<p>Oprire în curs de mișcare printr-o nouă apăsare pe tasta activată.</p>	
<p>Închidere printr-o nouă apăsare pe tasta activată.</p>	

► Activarea deschiderii pentru pietoni



Tasta 1 a telecomenzilor cu 2 sau 4 taste nu poate fi programată pentru a comanda deschiderea pentru pietoni a porții de acces. Consultați „Prezentarea telecomenzilor” de la pagina 27 pentru mai multe informații.

1		2		3	
<p>Apăsați 2 s pe butonul al sistemului electronic de comandă. Indicatorul luminos se aprinde.</p>		<p>Orientați telecomanda spre ținta sistemului electronic de comandă.</p>		<p>Apăsați pe tasta 2 a telecomenzii. Indicatorii luminoși „RADIO” și se aprind, apoi se sting. Deschiderea pentru pietoni este activată pe această tastă.</p>	



Îndepărtați-vă de sistemul electronic de comandă pentru a testa deschiderea pentru pietoni.

► Dezactivarea deschiderii pentru pietoni

Repețiți procedura „Activarea deschiderii pentru pietoni” cu tasta pentru care trebuie să fie dezactivată deschiderea pentru pietoni. Indicatorul luminos se aprinde, apoi se stinge. Deschiderea pentru pietoni este dezactivată pe această tastă.

4.2 Închiderea automată

► Funcționarea închiderii automate

Apăsați pe tasta 1 a telecomenzii pentru a deschide poarta de acces.









Poarta de acces se închide din nou după 30 de secunde sau 5 secunde, dacă este detectată o trecere de către celulele fotoelectrice.

Închiderea automată a porții de acces poate fi întreruptă prin apăsarea tastei 1 a telecomenzii. Pentru a închide poarta de acces din nou, apăsați din nou pe tasta 1 a telecomenzii.

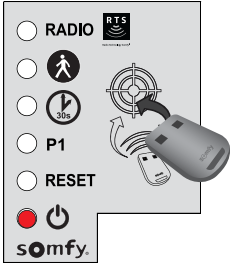
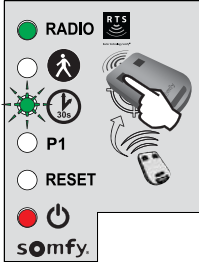

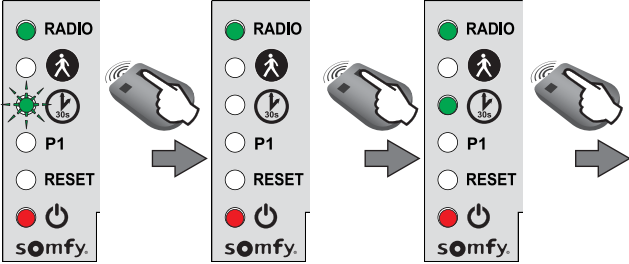

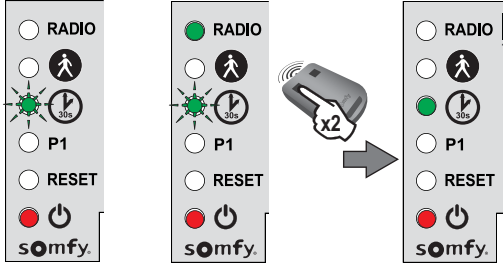



► Activarea închiderii automate

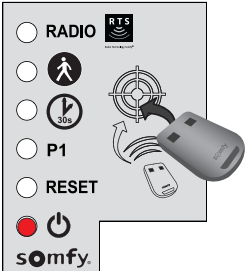
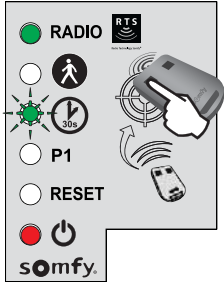

Închiderea automată nu poate fi activată decât dacă celulele fotoelectrice sunt cablate și recunoscute de sistemul electronic de comandă a motorului.

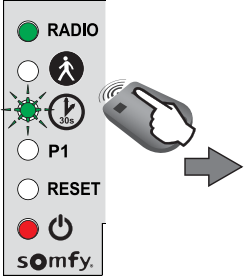
<p>1</p>  <p>Apăsați 2 s pe butonul  al sistemului electronic de comandă. Indicatorul luminos  se aprinde.</p>	<p>2</p>  <p>Orientați telecomanda spre ținta sistemului electronic de comandă.</p>	<p>3</p>  <p>Mențineți apăsată tasta 1 a telecomenzii până când indicatorul luminos  clipește.</p> <div data-bbox="1171 770 1410 1032" style="border: 1px solid orange; padding: 5px;"> <p>i</p> <p>Odată efectuată etapa 3, veți putea efectua etapele următoare de la distanță (fără a orienta telecomanda spre țintă).</p> </div>
<p>4</p>  <p>Mențineți apăsată tasta 2 a telecomenzii până când indicatorul luminos  se stinge, apoi se aprinde continuu.</p>		<p>5</p>  <p>Când tasta 2 este eliberată, indicatorul luminos  clipește, apăsați de 2 ori pe tasta 1 a telecomenzii. Indicatorul luminos  rămâne aprins. Închiderea automată este activată.</p>

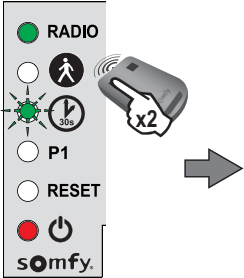
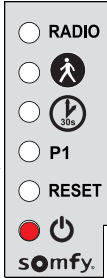
▶ Dezactivarea închiderii automate

<p>1</p>  <p>Apăsați 2 s pe butonul  al sistemului electronic de comandă. Indicatorul luminos  se aprinde.</p>	<p>2</p>  <p>Orientați telecomanda spre ținta sistemului electronic de comandă.</p>	<p>3</p>  <p>Mențineți apăsată tasta 1 a telecomenzii până când indicatorul luminos  clipește.</p>
<p>4</p>  <p>Apăsați pe tasta 2 a telecomenzii. Indicatorul luminos  clipește.</p>	<p>5</p>  <p>Apăsați de 2 ori pe tasta 1 a telecomenzii.</p>	<p>6</p>  <p>Indicatorul luminos  este stins. Închiderea automată este dezactivată.</p>

5.1 Prezentarea telecomenzilor

Telecomenzile RTS Somfy pot comanda, în funcție de opțiunile de parametrizare:

- deschiderea totală a porții de acces
- deschiderea pentru pietoni a porții de acces
- un alt echipament Somfy RTS (de exemplu: motor de ușă de garaj, rulou etc.)

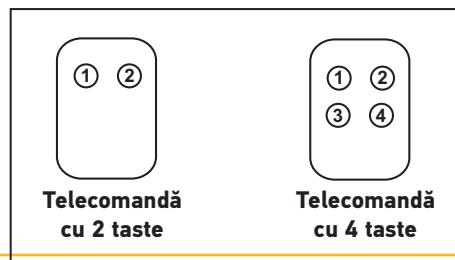

Telecomenzile livrate în kit sunt deja memorate și programate astfel încât tasta 1 a telecomenzilor să comande deschiderea totală a porții de acces.



Puteți memora până la 16 puncte de comandă (telecomenzi, alt punct de comandă radio). Dacă memorați un al 17-lea punct de comandă, primul punct memorat va fi șters automat.



Dacă doriți să programați o deschidere pentru pietoni, aceasta trebuie obligatoriu să fie programată pe tasta care urmează după cea pentru deschidere totală (de ex.: deschidere totală comandată de tasta 2, deschidere pentru pietoni comandată de tasta 3). Programarea deschiderii pentru pietoni pe tasta 1 a telecomenzilor este imposibilă.

▶ Opțiuni de programare a telecomenzii cu 2 taste

	Tasta 1	Tasta 2
Opțiunea 1	Deschidere totală	Deschidere pentru pieton sau alt automatism Somfy RTS
Opțiunea 2	Alt echipament Somfy RTS	Deschidere totală

▶ Opțiuni de programare a telecomenzii cu 4 taste

	Tasta 1	Tasta 2	Tasta 3	Tasta 4
Opțiunea 1	Deschidere totală	Deschidere pentru pieton sau alt automatism Somfy RTS	Alt automatism Somfy RTS	Alt automatism Somfy RTS
Opțiunea 2	Alt automatism Somfy RTS	Deschidere totală	Deschidere pentru pieton sau alt automatism Somfy RTS	Alt automatism Somfy RTS
Opțiunea 3	Alt automatism Somfy RTS	Alt automatism Somfy RTS	Deschidere totală	Deschidere pentru pieton sau alt automatism Somfy RTS
Opțiunea 4	Alt automatism Somfy RTS	Alt automatism Somfy RTS	Alt automatism Somfy RTS	Deschidere totală

▶ Utilizarea unei telecomenzi cu 3 taste

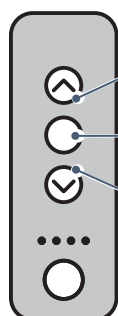

Deschidere

Pentru a deschide complet poarta de acces, apăsați pe tasta „Săgeată în sus” a telecomenzii.

Oprire

Pentru a opri poarta de acces în curs de mișcare, apăsați pe tasta centrală a telecomenzii.

Închidere



Pentru a închide poarta de acces, apăsați pe tasta „Săgeată în jos” a telecomenzii.





Telecomanda cu 3 taste nu poate fi utilizată pentru a modifica parametrizarea motorului.

5.2 Adăugarea unei telecomenzi

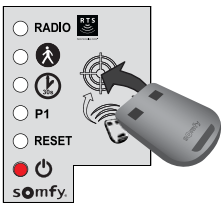
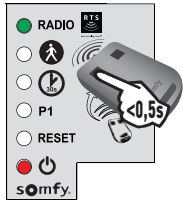
► Telecomandă cu 2 sau 4 taste

<p>1</p>  <p>Apăsați 2 s pe butonul  al sistemului electronic de comandă. Indicatorul luminos  se aprinde.</p>	<p>2</p>  <p>Orientați noua telecomandă de programat spre ținta sistemului electronic de comandă.</p>	<p>3</p>  <p>Apăsați scurt tasta telecomenzii de programat. Indicatorul luminos „RADIO” se aprinde, apoi se stinge când eliberați tasta telecomenzii. Deschiderea totală este programată pe această tastă.</p>
--	---	---

► Telecomandă cu 3 taste

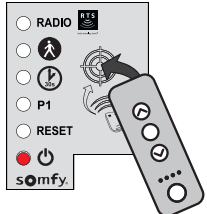
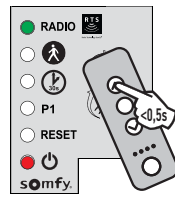
<p>1</p>  <p>Apăsați 2 s pe butonul  al sistemului electronic de comandă. Indicatorul luminos  se aprinde.</p>	<p>2</p>  <p>Orientați noua telecomandă de programat spre ținta sistemului electronic de comandă.</p>	<p>3</p>  <p>Apăsați scurt pe o tastă a telecomenzii de programat. Indicatorul luminos „RADIO” se aprinde, apoi se stinge când eliberați tasta telecomenzii. Telecomanda este memorată.</p>
---	--	---

5.3 Ștergerea telecomenzilor

Consultați „Ștergerea reglajelor”, pagina 30.







Motorizarea trebuie să fie deconectată de la orice sursă de alimentare în timpul curățării, întreținerii și în timpul înlocuirii componentelor.

6.1 Asistență

Dacă defecțiunea persistă, dacă aveți orice altă problemă sau doriți informații cu privire la motorizarea dumneavoastră, contactați-ne pe www.somfy.com

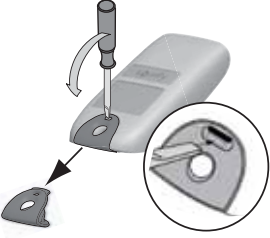
6.2 Încărcarea bateriei telecomenzii

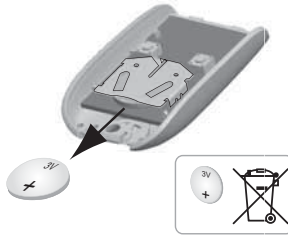





În general, durata de viață constatată a bateriei este de 2 ani.

<p>1</p>  <p>Îndepărtați clipsul telecomenzii.</p>	<p>2</p>  <p>Introduceți șurubelnița în fantă și ridicați capacul.</p>	<p>3</p>  <p>Scoateți bateria cu ajutorul unei șurubelnițe.</p>	<p>4</p>  <p>Înlocuiți bateria (3 V CR 2430 sau CR 2032).</p>
--	--	--	---

6.3 Ștergerea reglajelor

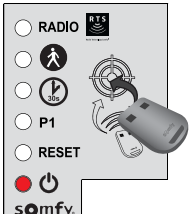
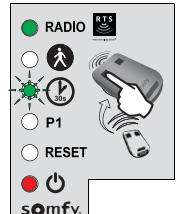
În ce cazuri trebuie șterse reglajele?

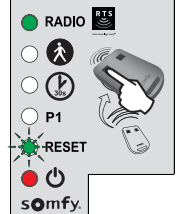
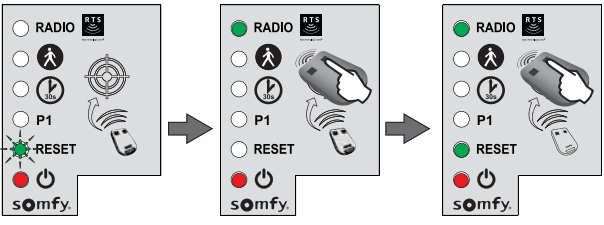
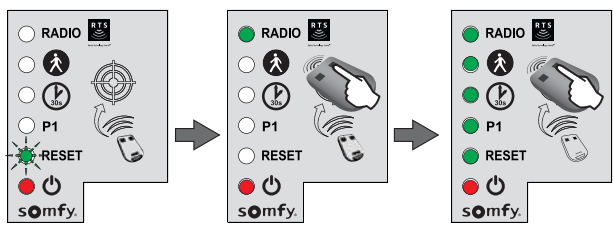
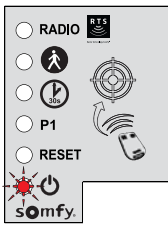
- După învățarea cursei porții de acces, dacă schimbați opritorul de deschidere a poziției sau dacă modificați cablajul motoarelor.
- În caz de redeschideri aleatorii ale porții de acces datorită unei uzuri normale a porții de acces.

<p>1</p>  <p>Apăsați 2 s pe butonul  al sistemului electronic de comandă. Indicatorul luminos  se aprinde.</p>	<p>2</p>  <p>Orientați telecomanda memorată spre țintă.</p>	<p>3</p>  <p>Mențineți apăsată tasta 1 a telecomenzii până când indicatorul luminos  clipește.</p>	<p>4</p>  <p>Apăsați 1 dată pe tasta 1 a telecomenzii. Indicatorul luminos „RESET” clipește.</p>
<p>5 Pentru a șterge reglajele*</p>  <p>Mențineți apăsată tasta 2 a telecomenzii până când indicatorul luminos „RESET” se aprinde.</p>		<p>5 Pentru a șterge reglajele* și telecomenzile/punctele de comandă memorate</p>  <p>Mențineți apăsată tasta 2 a telecomenzii până când se aprind toți indicatorii luminoși.</p>	
<p>6</p> 		<p>Indicatorul luminos  clipește de 2 ori (consultați „Autoînvățarea cursei porții de acces”, pagina 20).</p>	

*Cursa porții de acces, dezactivarea parametrilor, ...

6.4 Deblocarea / blocarea motoarelor

Prin deblocarea motoarelor, poarta de acces poate fi manevrată manual în caz de defecțiune electrică.

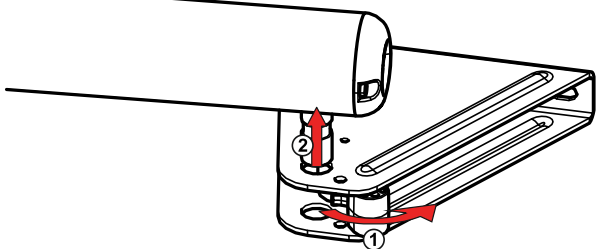
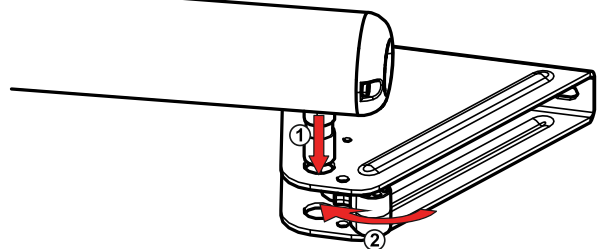
<p>1</p>  <p>Deblocarea motoarelor Desprindeți piesa de deblocare, apoi scoateți cilindrul din suportul de fixare a canalului.</p>	<p>2</p>  <p>Blocarea motoarelor Instalați cilindrul. Prindeți piesa de deblocare pe degetul de antrenare pentru a-l bloca.</p>
---	---

6.5 Diagnosticare

DIAGNOSTICARE		DEPANARE
Motoarele nu răspund la comenzile telecomenzii	Rază de acțiune redusă a telecomenzii	- Verificați bateria telecomenzii (consultați „Înlocuirea bateriei telecomenzii” de la pagina 29). - Verificați antena unității de comandă (cablaj, poziție, consultați pagina 16). - Verificați să nu existe vreun element exterior susceptibil să perturbe emisiile radio (stâlp electric, pereți metalici etc.). În caz contrar, prevedeați o antenă de comandă la distanță.
	Telecomandă nememorată	Memorați telecomanda (consultați pagina 28).
	Motoare cablate necorespunzător	Verificați cablajul motoarelor (consultați pagina 18).
Indicatorul luminos ☺ al unității de comandă este stins	Sistemul electronic este în stare de veghe	Apăsăți 2 s pe butonul ☺ pentru a reactiva sistemul electronic de comandă.
	Sistem electronic de comandă nealimentat	- Verificați alimentarea de la rețeaua electrică. - Verificați cablul de alimentare.
Indicatorul luminos ☺ al unității de comandă clipește:		
1 clipire	Funcționarea pe baterie de rezervă	Verificați alimentarea de la rețeaua electrică.
2 clipiri	Motor în așteptarea autoînvățării	Lansați autoînvățarea cursei porții de acces (consultați pagina 20).
3 clipiri	Celule fotoelectrice defecte	- Verificați dacă nu există vreun obstacol între celule. - Verificați alinierea celulelor. - Verificați cablajul celulelor (consultați pagina 22). - Dacă celulele sunt debransate în mod intenționat, efectuați procedura „Dezactivarea închiderii automate” de la pagina 26.
4 clipiri	Comandă permanentă pe „START” a unității electronice (bornele 5-6)	Verificați accesoriile branșate pe „START” a unității de comandă.
5 clipiri	Siguranță termică a sistemului electronic anclanșată	Lăsați sistemul electronic să se răcească până când indicatorul luminos ☺ se reaprinde continuu.
6 clipiri	Scurtcircuit la „MAGISTRALA” unității de comandă (bornele 3-4)	Verificați accesoriile branșate pe „MAGISTRALA” unității electronice.
	Scurtcircuit pe „24 V” de la unitatea electronică (bornele 7-9)	Verificați accesoriul branșat pe „24 V” de la unitatea electronică.
	Scurtcircuit „lampă de semnalizare” de la unitatea electronică (bornele 8-9)	Verificați cablajul lămpii de semnalizare (consultați pagina 22).
	Scurtcircuit la motor	Verificați cablajul motoarelor (consultați pagina 18).
7 clipiri	Defecțiune electronică	Contactați serviciul de asistență Somfy.
Poarta de acces se redeschide la sfârșitul mișcării de închidere		Slăbiți suporturile canaturilor și decalați-le ușor spre centrul porții de acces.

Alimentare	230 V-50Hz / 24V (mod solar)
Tip de motor	24 V
Putere motor	120 W
Putere maximă consumată (cu iluminare de zonă)	600 W
Consum în stare de veghe	3 W (fără accesorii)
Frecvență maximă de manevre pe zi	20 cicluri / zi 10 cicluri / zi în modul solar
Timp de deschidere	Minim 20 s la 90°
Detectare automată de obstacole	Conform normei EN 12 453
Temperatură de funcționare	De la -20°C la +60°C
Protecție termică	Da
Clasă de protecție	IP 44
Receptor radio integrat	Da
Telecomenzi: - Frecvență radio - Rază de acțiune în câmpul de utilizare - Cantitate memorabilă	433,42 MHz, < 10 mW ~ 30 m 16
Conexiuni posibile: - leșire pentru lampă de semnalizare - leșire iluminare - leșire alimentare accesorii - Intrare pentru bateria de rezervă - Intrare pentru celule fotoelectrice - Intrare comandă de tip contact fără potențial	Clipitoare, 24 V, 10 W maxim 500 W max. la 230 V (numai cu halogen sau cu incandescență) 24 Vcc / 15 W max. Da Da Da (nu funcționează dacă alimentarea este pe baterie sau energie solară)

Somfy France

0 820 055 055 (0,15€ la minute)

Forum d'entraide : forum.somfy.fr

Somfy GmbH

07472 / 930 - 495

www.somfy.de

Somfy Romania S.R.L.

(+4) 0374 494 418

www.somfy.ro

Somfy Nederland B.V.

023 56 23 752

www.somfy.nl

Somfy Belux NV.

02 712 07 70

www.somfy.be

Somfy Ltd.

(+44) 0113 391 3030

www.somfy.co.uk

Somfy Sp. z o.o

810377199

www.somfy.pl

Somfy España SA

900 20 68 68

www.somfy.es

Somfy Portugal

808100153

www.somfy.pt

Somfy Hellas SA

211 6000 222

www.somfy.gr

Somfy Italia SRL

800827151

www.somfy.it

SOMFY ACTIVITES SA

50 avenue du Nouveau Monde

74300 CLUSES

FRANCE

www.somfy.com

