

Elixo 2000 230V RTS
MOTORIZATION FOR SLIDING GATE



Robust & unalterable
DESIGNED FOR HEAVY GATES
WITH INTENSIVE USE



ELIXO 2000 230V RTS

The robust and secure solution



Robust for an intensive use

- **Very intensive use**, the motor can work permanently and it has been tested for **180,000 cycles on a 10 m and 2,000 kg gate**.
- **The oil bath gearbox** minimizes component wear, so they are **permanently lubricated and perfectly cooled**.



Protect the installation

- Motors are protected by **individual keys**, for locking or unlocking.
- **Encoder technology:** electronically controlled movement, safe and constant, to ensure a maximum of tranquility and security to gate users.
- **Anticrush security:** guaranteed by the electronic system that detects the presence of obstacles.
- **The irreversibility of the motor** guarantees a perfect locking of the gate in closed position thus avoiding any possibility of intrusion.



Adjustable settings

- **The motor torque** and the **soft stop** functions are automatically set during the autosegment parameter to suit the weight of the gate, to ensure efficiency and preserve the gate. These parameters can be adjusted after the autosegment adapt to each use.
- **Adjustable partial opening position** for pedestrians and cyclists.
- **Automatic closure**, operating modes possible to meet all your needs.
- **Possible to adjust the energy** during the slowdown phase (brake parameter).

DESIGNED FOR HEAVY GATES AND INTENSIVE USE

20 m - 2,000 kg



Individual key for declutching



Fully protected

Electronic and motor are hermetically protected from external agents (sand, insects...).

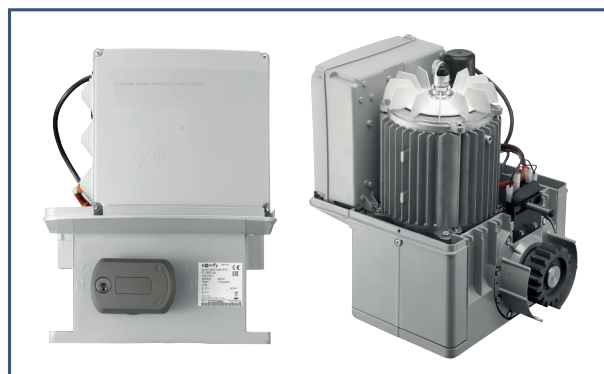

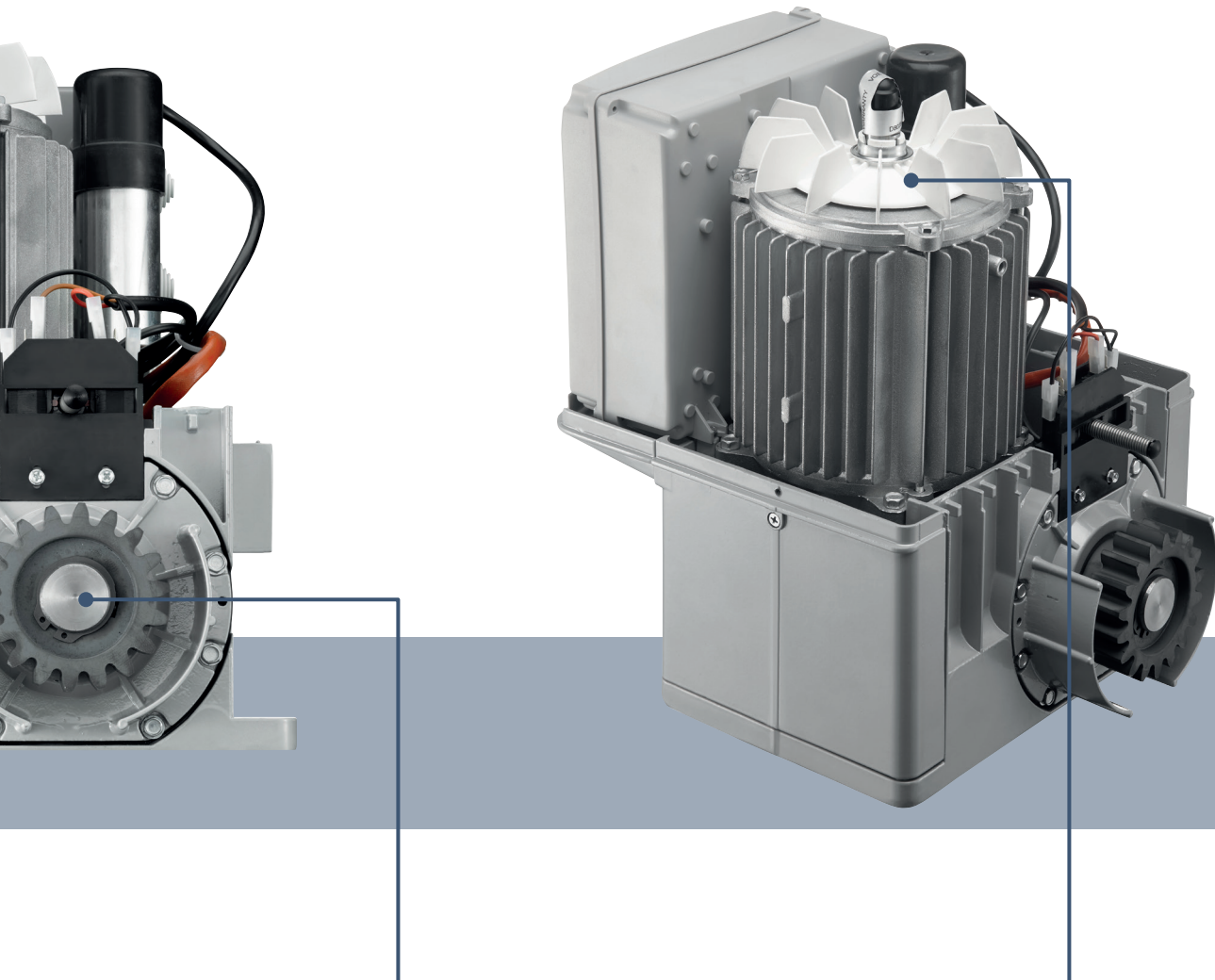

Safety and precision

Encoder technology to control the position and the movement of the gate.

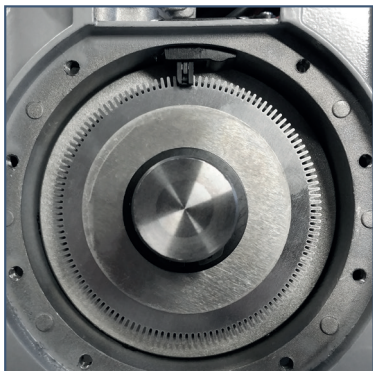

Robustness and durability

Oil bath gearbox permanently lubricated and perfectly cooled.



Technical characteristics

Designation	Value
Power supply	220-230 Vac 50/60 Hz
Power consumption	750 W
Maximum torque	40 Nm
Speed	9 m/min
Maximum gate leaf weight	2,000 kg
Maximum gate leaf length	20 m

Designation	Value
Lubrication	Oil bath
Manual operation	Release using individual key
Climatic operating conditions	- 20°C/+ 55°C - IP 24
Noise level	< 70 dBA
Radio frequency))) 433.42 MHz < 10 mW
Number of storable channels	32

General overall size

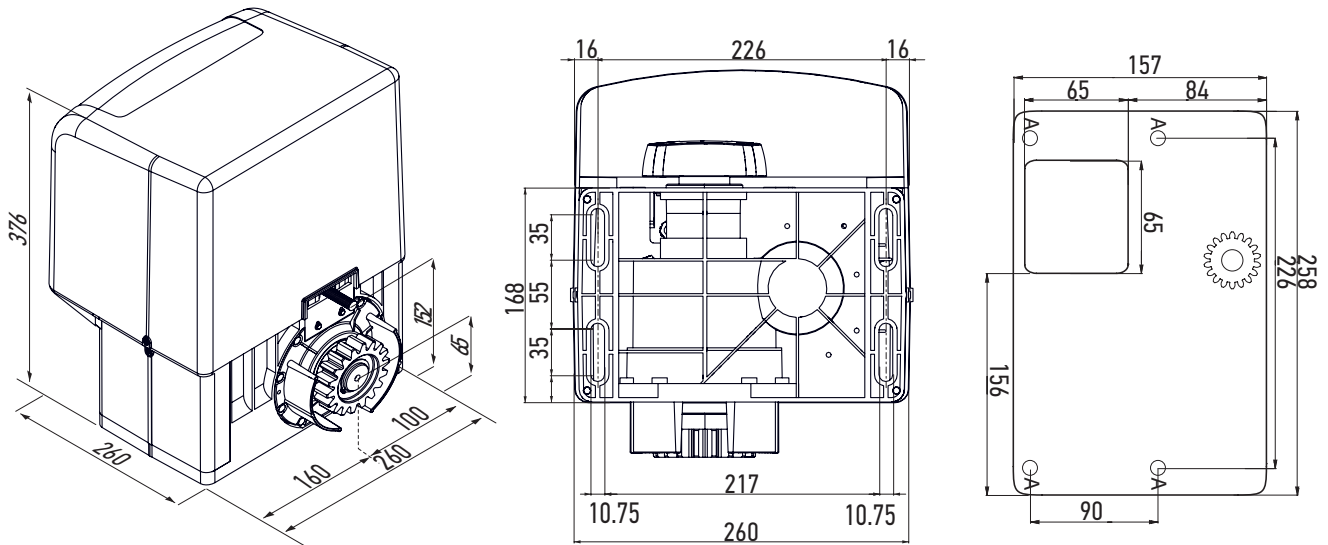

Packs



Elixo 2000 230V RTS	Keygo RTS	Foundation plate	Minimum order quantity
	Ref. 1841064	-	

Standard pack RTS	• 1x	• 2x	• 1x	1
Ref. 1216595				
Palett pack RTS	• 1x	• 2x	• 1x	8
Ref. 1216600				



**2 meter steel Rack
22 mm x 22 mm**



**1 meter steel Rack
30 mm x 12 mm**

Steel rack 22 mm	• 1x
Ref. 9020919	

Steel rack 12 mm	• 1x
Ref. 9011069	

SOMFY ACTIVITÉS SA

50 avenue du Nouveau Monde

74300 CLUSES

FRANCE

T +33 (0)4 50 96 70 00

F +33 (0)4 50 96 71 89

www.somfy.com

A BRAND OF **SOMFY** GROUP