

ELIXO 500 24V RTS

Product reference	1216363 _ 1216364	Cancels & replaces	1216313 _ 1216314
EAN Code	/	Guarantee	3 years
Pack dimensions (LxHxD)	40 x 25,5 x 31,5 (cm)	Marketing date	January 2013
Weight	9,6 kg		
Pack type	White box		
Minimum order	1		
Delivery mode	According to delivery (pallet or box)	MADE IN Italy www.somfy.com	

Content of a standard pack :

1	Elixo 24 V Motor	x 1
2	Keygo RTS remote control	x 2
Ground mounting kit:		
3a	Lag screws	x 4
3b	Nut	x 8
3c	Washer	x 8
3d	Plug	x 4
4	Manual release handle assembly	x 1
5	Handle locking key	x 2
6	End limit brackets	x 2
7	Drilling template	x 1

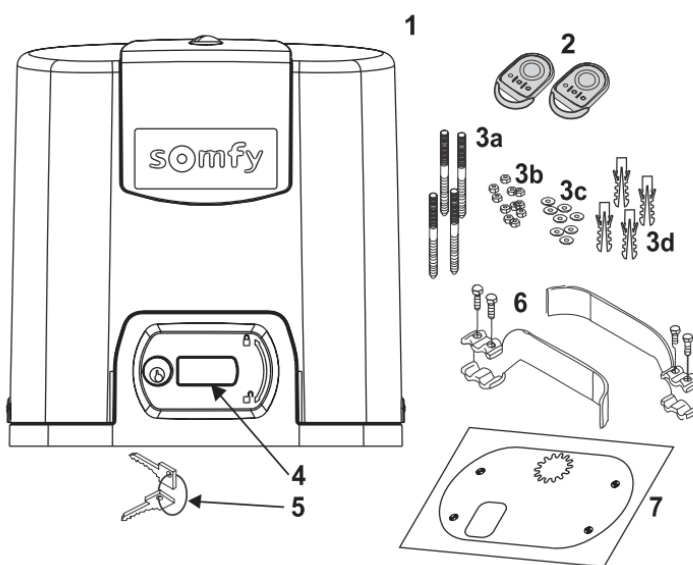

Area of application:

Sliding gates up to 500 kg and carrying out 30 manoeuvres per day

General overall size

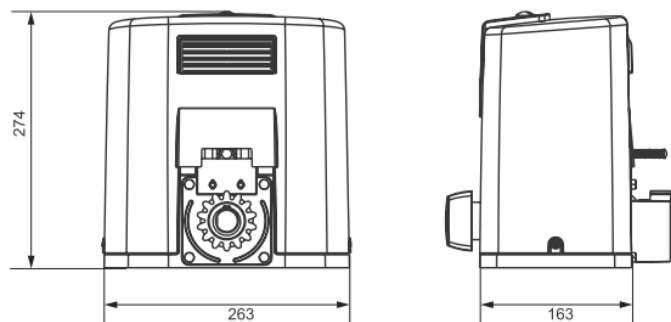

Accessories:

1 meter nylon rack top fastening	9011090
1 meter nylon rack bottom fastening	9011089
Keygo RTS	1841064
Keypad metal RTS	1841116
24V amber light with antenna	9014082
24V amber light without antenna	9017842
Photo electric cells	1841155
Photo electric metal protection cover	9015132
Rubber strip low profile	9014597
Rubber strip big profile	9014598
Back up battery	9016732

